

TPM+ product range Rotary Servo Actuators

More productive
More efficient
More precise





Contents **TPM+ product range**

Overview	4
TPM+ dynamic, introduction	6
Size 004, technical data and dimensions	8
Size 010, technical data and dimensions	10
Size 025, technical data and dimensions	12
Size 050, technical data and dimensions	14
Size 110, technical data and dimensions	16
TPM+ high torque, introduction	18
Size 004, technical data and dimensions	20
Size 010, technical data and dimensions	22
Size 050, technical data and dimensions	24
Size 110, technical data and dimensions	26
TPM+ power, introduction	28
Size 004, technical data and dimensions	30
Size 010, technical data and dimensions	34
Size 025, technical data and dimensions	38
Size 050, technical data and dimensions	42
Size 110, technical data and dimensions	46
TPM+ endurance, introduction	50
Size 010, technical data and dimensions	52
Size 050, technical data and dimensions	52
Options for our servo actuators	54
Servo controller overview	56
Pin assignment overview	57
Order codes for TPM+	60
Assignment matrix	61
Order codes for TPM+ power/signal cable	62
Pre-assembled cables	63
Information	64

A system functions best when all the individual parts are integrated perfectly. The harmonious combination of motors, precision gearheads, electronics, sensors and software integrated in bus-compatible, electromechanical rotary and linear servo systems manufactured by WITTENSTEIN motion control GmbH is more than impressive. Integration plays an innovative role here and is a decisive factor in increasing power density and dynamics.

Overview of the **TPM+ product range**

TPM+ product declaration

Actuators

The TPM+ product family is above all dynamic and compact. Servo motors and gearheads merge seamlessly into a single versatile unit. The benefit: Maximum power density meets functional design, including genuine benefits in terms of length.

Motors

Outstanding performance: Rare earth magnets, a high pole count and a high copper fill factor in the permanent magnet excited synchronous servo motors result in high power density are barely discernable cogging torques.

Gearheads

Precision is the greatest strength. The planetary gearheads offer minimal backlash while achieving a high degree of torsional and tilting rigidity. The smooth-running helical teeth guarantee silent operation.

TPM+: More productive – More efficient – More precise

More productive ...

The benefits for your machines and plants: An actuator with a low moment of inertia and an extremely rigid drive train. For maximum precision, dynamics and extra productivity.

More efficient ...

Low torsional backlash, an output bearing with a high degree of tilting rigidity and integration of the gearhead pinion in the motor shaft result in smaller motors as well as reducing energy consumption and investment costs for the overall drive train.

More precise ...

Two negatives make a positive: Low levels of operating noise due to helical teeth and outstanding control properties ensure greater precision in your machines and plants. The result: Genuinely economical products.

Other features at a glance:

Different encoder systems and permanent magnet holding brake available

Torsional backlash can be reduced to less than 1 arcmin

UL version as standard

Pre-assembled cables available for selected servo controllers

Special instructions for selected servo controllers guarantee easy setup

Electrical connections feature convenient bayonet connectors

Direct attachment of drive components (pinion, belt pulley, indexing table) to standardized output flange

Robust output bearing eliminates the need for additional bearing points

The TPM+ product range is most impressive! Exemplary dynamics, torque and torsional rigidity. Combined with an extremely short overall length, high power density and superior running on a completely new level together with practical graduated performance settings that ensure greater operating efficiency in all your production applications.

TPM+ dynamic

More dynamic – Shorter – Quieter

Extra productivity: Outstanding dynamics, compact dimensions and superior running. Actuator with two-stage gearhead designed primarily for rotary applications.

TPM+ power

Stronger – Quieter – More compact

Extra power: High torque, compact dimensions. Single or two-stage motor gearhead combination for linear and rotary applications.

TPM+ high torque

Stronger – More compact – More torsionally rigid

Extra rigid: High torsional rigidity and high power density. Two or three-stage servo actuator for heavy-duty applications.

TPM+ endurance

More dynamic – Shorter – Cooler

Extra cool: High power density, high performance. Water-cooled, one-stage actuator for linear applications.

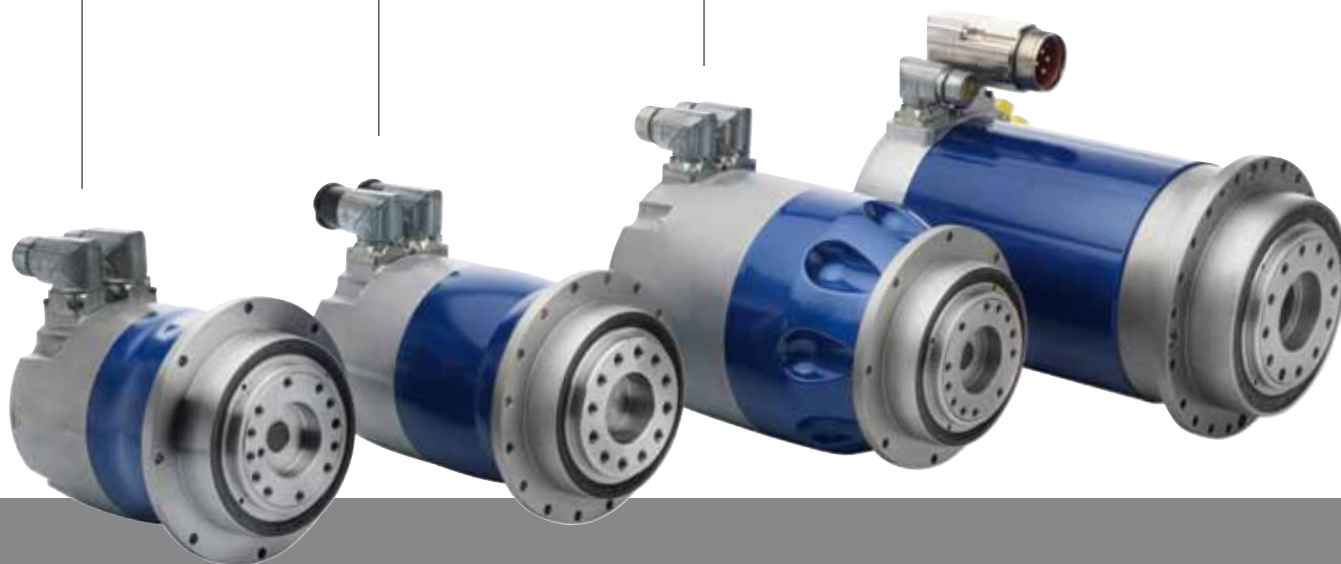

Servo actuators **TPM+ dynamic**

TPM+ dynamic servo actuators

Enhanced operating efficiency!

With the dynamic motor gearhead unit in functional design.



It's your game!

TPM+ dynamic: The motor gearhead unit with extremely short response times. The TPM+ dynamic gives you everything: Perfect power density, small dimensions, low sensitivity to dirt and silent operation thanks to a modern design. Real winners rely on the technology of the TPM+ dynamic. And prepare you for any situation, even when the going gets tough. Game, set and match!



Source: Groninger & Co. GmbH



Source: Bosch Packaging Systems AG

Applications

Whether used as an axle drive on spraying robots, a swivel drive in the production of optical components and semiconductors, in packaging machines for manufacturing seals or as a drive for changeover systems in tool machining or wood processing systems, the TPM+ dynamic is ideal for all robotic and automated applications.

Packaging

Robotics

Size TPM+ dynamic	Length from	Max. acceleration torque	Max. power
004	113 mm	40 Nm	1.0 kW
010	142 mm	100 Nm	1.5 kW
025	153 mm	300 Nm	4.7 kW
050	187 mm	650 Nm	10.2 kW
110	268 mm	1300 Nm	14.2 kW

More dynamic ...

Experience extraordinary dynamics: Through modern motor technology boasting high power density, a low moment of inertia and optimized torsional rigidity.

Shorter ...

Benefit from a reduced length: Thanks to a seamless connection between motor and gearhead as well as the space-saving attachment of motor instruments, over 50 percent more compact than conventional gearhead motors.

Quieter ...

Power behind the silence: Helical-toothed precision planetary gearheads ensure low-vibration operation that is as quiet as a whisper.



TPM+ dynamic

TPM+ dynamic 004

Ratio	i	16		21		31		61		64		91	
		320	560	320	560	320	560	320	560	320	560	320	560
Intermediate circuit voltage	U_D V DC												
Max. acceleration torque at output (max. 1000 cycles per hour)	T_{2B} Nm	30		32		40		32		32		32	
Static output torque	T_{20} Nm	8		11		17		15		15		15	
Brake holding torque at output, 100°C	T_{2BR} Nm	18		23		34		67 ¹⁾		70 ¹⁾		100 ¹⁾	
Max. speed	n_{2max} rpm	375		286		194		98		94		66	
Speed limit for T_{2B}	n_{2B} rpm	313		262		189		98		94		66	
Max. acceleration torque of motor	T_{Mmax} Nm	2.0		2.0		2.0		1.0		1.0		1.0	
Max. acceleration current of motor	I_{maxdyn} A _{eff}	5.5	3.2	5.5	3.2	5.5	3.2	4.2	2.4	4.2	2.4	4.2	2.4
Static motor current	I_0 A _{eff}	1.9	1.1	1.9	1.1	1.9	1.1	1.4	0.8	1.4	0.8	1.4	0.8
Moment of inertia (on motor shaft, without brake, with resolver)	J_i kgm ² ·10 ⁻⁴	0.21		0.20		0.20		0.12		0.11		0.12	
Torsional backlash	j_t arcmin	Standard ≤ 4 / Reduced ≤ 2											
Torsional rigidity	C_t Nm/arcmin	-		10		9		9		-		7	
Tilting rigidity	C_K Nm/arcmin	-											
Max. axial force	F_{Amax} N	1630											
Max. tilting torque (distance from point of rotation to output flange 57.6 mm)	M_{Kmax} Nm	110											
Weight (with resolver, without brake)	m kg	2.2						2.0					
Operating noise (measured at motor speed of 3000 rpm)	L_{PA} dB(A)	≤ 58											
Max. permitted housing temperature	°C	+90											
Ambient temperature	°C	0 to +40											
Protection class		IP 65											
Mounting position		Any											
Lubrication		Synthetic oil, lubricated for life											
Insulating material class		F											
Paint		Metallic blue 250 and natural cast aluminum											

Tolerances T, I and n: Maximum +/- 10%.

¹⁾ greater than T_{2B} of the gearhead. In an emergency, can be used approx. 1000 times while the motor is rotating.

Please refer to the instructions and graphic illustration of the speed and torque values in the chapter "Information".

View A

View B

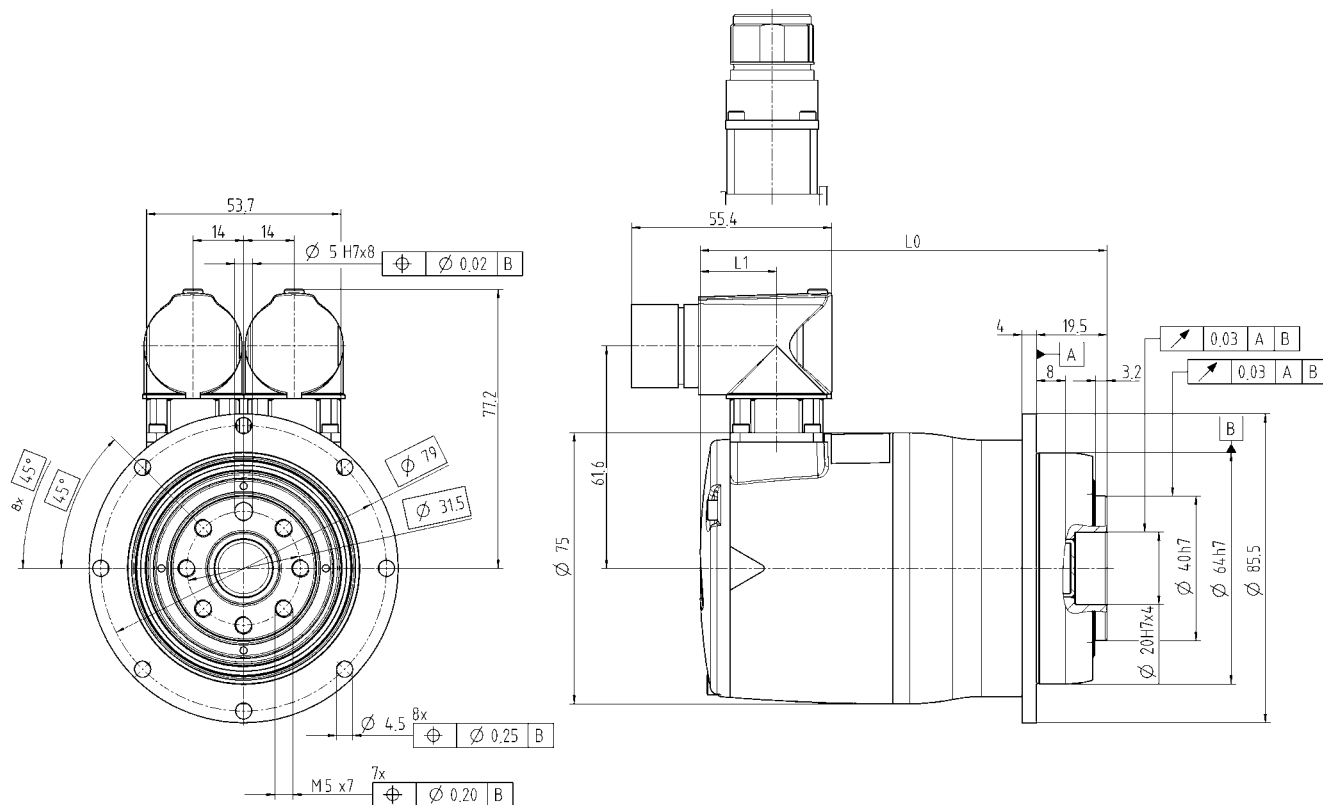

Electrical connection: Integral sockets, straight or angled, manufactured by Intercontec, SpeedTEC model, series A and B, size 1

without brake

Ratio	Motor feedback	Length L0 [mm]	Length L1 [mm]
i = 16/21/31	Resolver	128	22
	Hiperface	153	47
	EnDat	157	51
i = 61/64/91	Resolver	113	22
	Hiperface	138	47
	EnDat	142	51

with brake

Ratio	Motor feedback	Length L0 [mm]	Length L1 [mm]
i = 16/21/31	Resolver	165	22
	Hiperface	190	47
	EnDat	194	51
i = 61/64/91	Resolver	150	22
	Hiperface	175	47
	EnDat	179	51

TPM+ dynamic 010

Ratio	i	16		21		31		61		64		91	
		320	560	320	560	320	560	320	560	320	560	320	560
Intermediate circuit voltage	U_D V DC												
Max. acceleration torque at output (max. 1000 cycles per hour)	T_{2B} Nm	57		75		100		80		80		80	
Static output torque	T_{20} Nm	13		18		27		29		28		35	
Brake holding torque at output, 100°C	T_{2BR} Nm	18		23		34		67		70		100 ¹⁾	
Max. speed	n_{2max} rpm	375		286		194		98		94		66	
Speed limit for T_{2B}	n_{2B} rpm	256		195		132		81		78		54	
Max. acceleration torque of motor	T_{Mmax} Nm	3.8		3.8		3.8		1.9		1.9		1.9	
Max. acceleration current of motor	I_{maxdyn} A _{eff}	9.0	5.2	9.0	5.2	9.0	5.2	5.2	3.0	5.2	3.0	5.2	3.0
Static motor current	I_0 A _{eff}	2.3	1.3	2.3	1.3	2.3	1.3	1.6	0.9	1.6	0.9	1.6	0.9
Moment of inertia (on motor shaft, without brake, with resolver)	J_i kgm ² ·10 ⁻⁴	0.32		0.32		0.32		0.17		0.17		0.17	
Torsional backlash	j_t arcmin	Standard ≤ 3 / Reduced ≤ 1											
Torsional rigidity	C_t Nm/arcmin	-		26		24		24		-		21	
Tilting rigidity	C_K Nm/arcmin	225											
Max. axial force	F_{Amax} N	2150											
Max. tilting torque (distance from point of rotation to output flange 82.7 mm)	M_{Kmax} Nm	270											
Weight (with resolver, without brake)	m kg	4.8						4.3					
Operating noise (measured at motor speed of 3000 rpm)	L_{PA} dB(A)	≤ 62											
Max. permitted housing temperature	°C	+90											
Ambient temperature	°C	0 to +40											
Protection class		IP 65											
Mounting position		Any											
Lubrication		Synthetic oil, lubricated for life											
Insulating material class		F											
Paint		Metallic blue 250 and natural cast aluminum											

Tolerances T, I and n: Maximum +/- 10%.

¹⁾ greater than T_{2B} of gearhead. In an emergency, can be used approx. 1000 times while the motor is rotating.

Please refer to the instructions and graphic illustration of the speed and torque values in the chapter "Information".

View A

View B

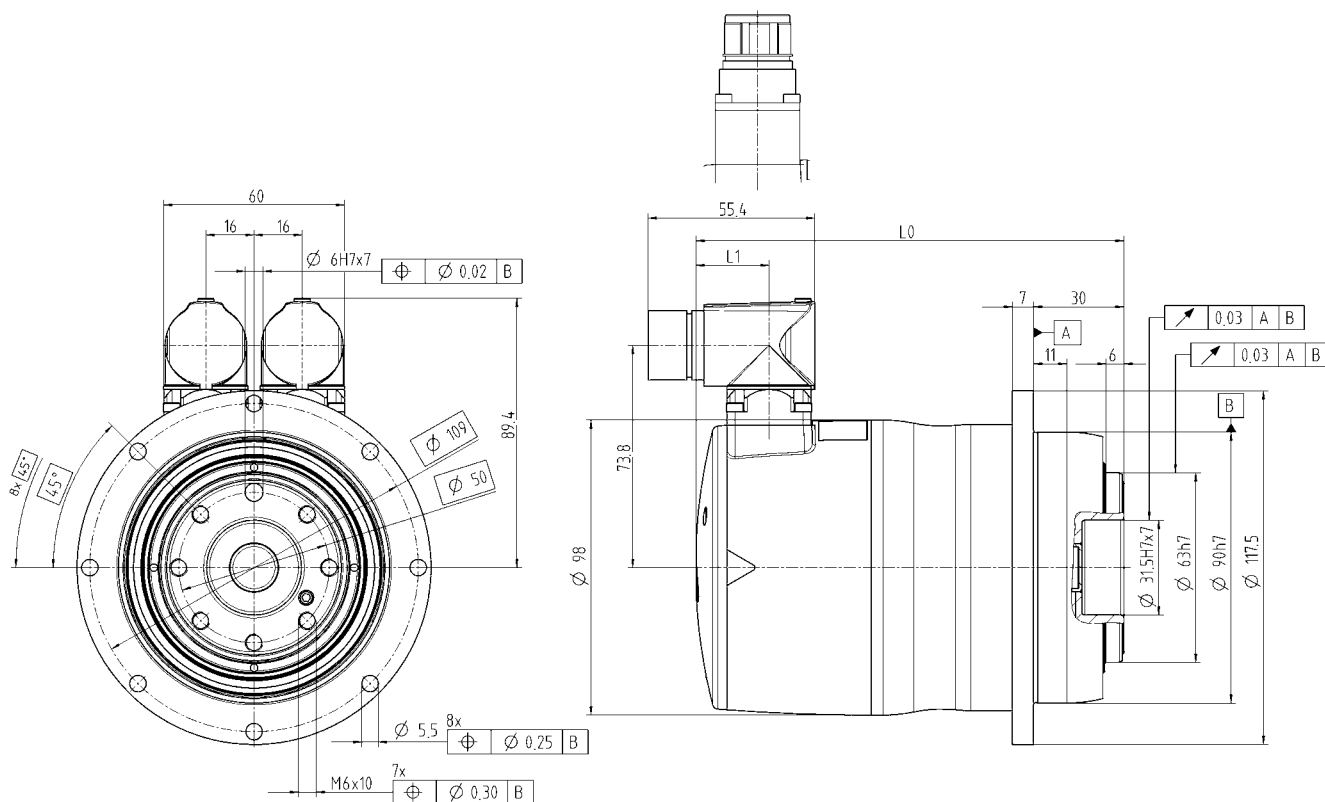

Electrical connection: Integral sockets, straight or angled, manufactured by Intercontec, SpeedTEC model, series A and B, size 1

without brake

Ratio	Motor feedback	Length L0 [mm]	Length L1 [mm]
i = 16/21/31	Resolver	157	24
	Hiperface	178	45
	EnDat	182	49
i = 61/64/91	Resolver	142	24
	Hiperface	163	45
	EnDat	167	49

with brake

Ratio	Motor feedback	Length L0 [mm]	Length L1 [mm]
i = 16/21/31	Resolver	178	24
	Hiperface	199	45
	EnDat	202	49
i = 61/64/91	Resolver	163	24
	Hiperface	184	45
	EnDat	187	49

TPM+ dynamic 025

Ratio	i	16		21		31		61		64		91	
		320	560	320	560	320	560	320	560	320	560	320	560
Intermediate circuit voltage	U _D V DC												
Max. acceleration torque at output (max. 1000 cycles per hour)	T _{2B} Nm	182		239		300		250		250		250	
Static output torque	T ₂₀ Nm	74		97		146		87		83		100	
Brake holding torque at output, 100°C	T _{2BR} Nm	72		94		140		274 ¹⁾		288 ¹⁾		410 ¹⁾	
Max. speed	n _{2max} rpm	375		286		194		98		94		66	
Speed limit for T _{2B}	n _{2B} rpm	244		185		125		59		56		39	
Max. acceleration torque of motor	T _{Mmax} Nm	12.1		12.1		12.1		4.4		4.4		4.4	
Max. acceleration current of motor	I _{maxdyn} A _{eff}	29.4	17.0	29.4	17.0	29.4	17.0	10.4	6.0	10.4	6.0	10.4	6.0
Static motor current	I ₀ A _{eff}	9.9	5.7	9.9	5.7	9.9	5.7	3.3	1.9	3.3	1.9	3.3	1.9
Moment of inertia (on motor shaft, without brake, with resolver)	J _i kgm ² ·10 ⁻⁴	2.16		2.16		2.17		0.77		0.76		0.76	
Torsional backlash	j _t arcmin	Standard ≤ 3 / Reduced ≤ 1											
Torsional rigidity	C _t Nm/arcmin	-		70		54		61		-		55	
Tilting rigidity	C _K Nm/arcmin	550											
Max. axial force	F _{Amax} N	4150											
Max. tilting torque (distance from point of rotation to output flange 94.5 mm)	M _{Kmax} Nm	440											
Weight (with resolver, without brake)	m kg	8.5						7.1					
Operating noise (measured at motor speed of 3000 rpm)	L _{PA} dB(A)	≤ 64											
Max. permitted housing temperature	°C	+90											
Ambient temperature	°C	0 to +40											
Protection class		IP 65											
Mounting position		Any											
Lubrication		Synthetic oil, lubricated for life											
Insulating material class		F											
Paint		Metallic blue 250 and natural cast aluminum											

Tolerances T, I and n: Maximum +/- 10%.

¹⁾ greater than T_{2B} of gearhead. In an emergency, can be used approx. 1000 times while the motor is rotating.

Please refer to the instructions and graphic illustration of the speed and torque values in the chapter "Information".

View A

View B

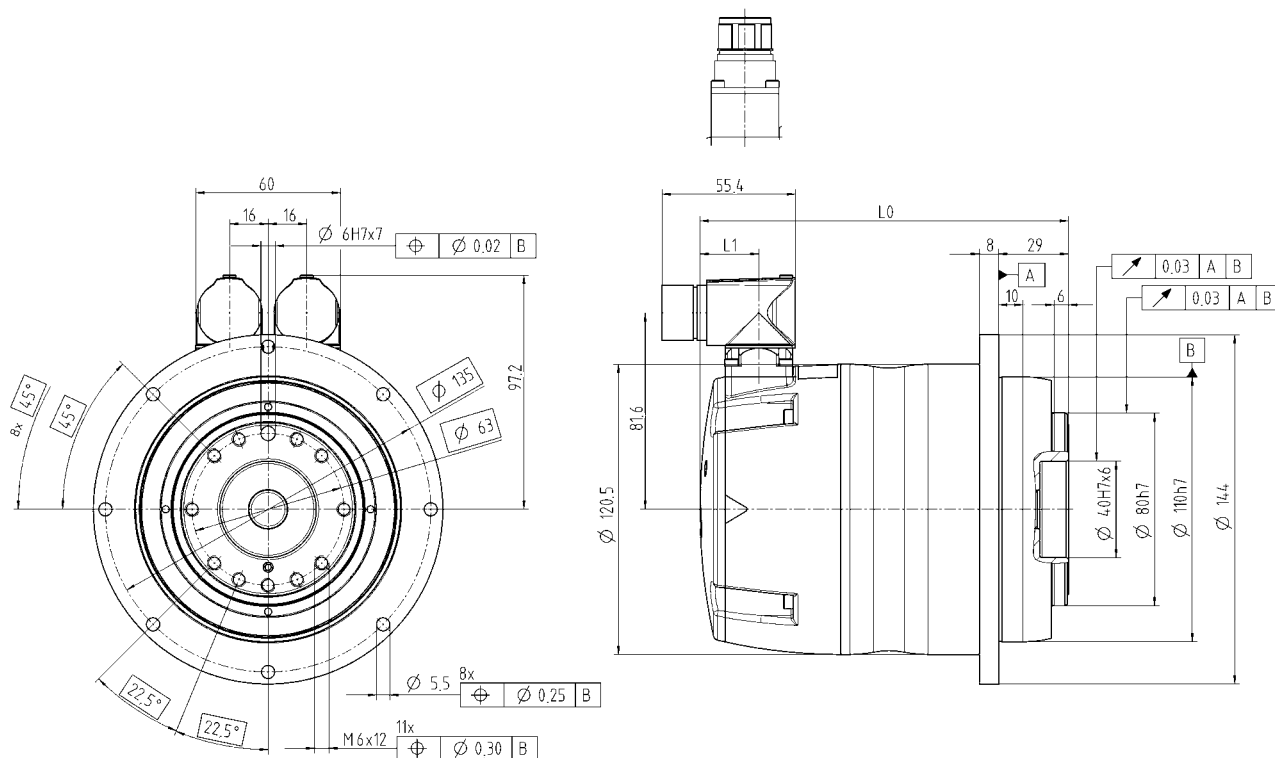

Electrical connection: Integral sockets, straight or angled, manufactured by Intercontec, SpeedTEC model, series A and B, size 1

without brake

Ratio	Motor feedback	Length L0 [mm]	Length L1 [mm]
i = 16/21/31	Resolver	183	24
	Hiperface	204	45
	EnDat	208	49
i = 61/64/91	Resolver	153	24
	Hiperface	174	45
	EnDat	178	49

with brake

Ratio	Motor feedback	Length L0 [mm]	Length L1 [mm]
i = 16/21/31	Resolver	202	24
	Hiperface	223	45
	EnDat	227	49
i = 61/64/91	Resolver	172	24
	Hiperface	193	45
	EnDat	197	49

TPM+ dynamic 050

Ratio	i	16		21		31		61		64		91	
		320	560	320	560	320	560	320	560	320	560	320	560
Intermediate circuit voltage	U_D V DC												
Max. acceleration torque at output (max. 1000 cycles per hour)	T_{2B} Nm	435		500		650		447		469		500	
Static output torque	T_{20} Nm	185		220		370		173		166		220	
Brake holding torque at output, 100°C	T_{2BR} Nm	208		273		403		793 ¹⁾		832 ¹⁾		1183 ¹⁾	
Max. speed	n_{2max} rpm	312		238		161		82		78		55	
Speed limit for T_{2B}	n_{2B} rpm	225		171		116		59		56		39	
Max. acceleration torque of motor	T_{Mmax} Nm	28.9		28.9		28.9		7.8		7.8		7.8	
Max. acceleration current of motor	I_{maxdyn} A _{eff}	70.0	40.0	70.0	40.0	70.0	40.0	21.0	12.0	21.0	12.0	21.0	12.0
Static motor current	I_0 A _{eff}	23.7	13.7	23.7	13.7	23.7	13.7	6.6	3.8	6.6	3.8	6.6	3.8
Moment of inertia (on motor shaft, without brake, with resolver)	J_1 kgm ² ·10 ⁻⁴	9.07		9.07		8.94		2.51		2.49		2.49	
Torsional backlash	j_t arcmin	Standard ≤ 3 / Reduced ≤ 1											
Torsional rigidity	C_t Nm/arcmin	-		145		130		123		-		100	
Tilting rigidity	C_K Nm/arcmin	560											
Max. axial force	F_{Amax} N	6130											
Max. tilting torque (distance from point of rotation to output flange 81.2 mm)	M_{Kmax} Nm	1335											
Weight (with resolver, without brake)	m kg	18.5						14.7					
Operating noise (measured at motor speed of 3000 rpm)	L_{PA} dB(A)	≤ 65											
Max. permitted housing temperature	°C	+90											
Ambient temperature	°C	0 to +40											
Protection class		IP 65											
Mounting position		Any											
Lubrication		Synthetic oil, lubricated for life											
Insulating material class		F											
Paint		Metallic blue 250 and natural cast aluminum											

Tolerances T, I and n: Maximum +/- 10%.

¹⁾ greater than T_{2B} of the gearhead. In an emergency, can be used approx. 1000 times while the motor is rotating.

Please refer to the instructions and graphic illustration of the speed and torque values in the chapter "Information".

View A

View B

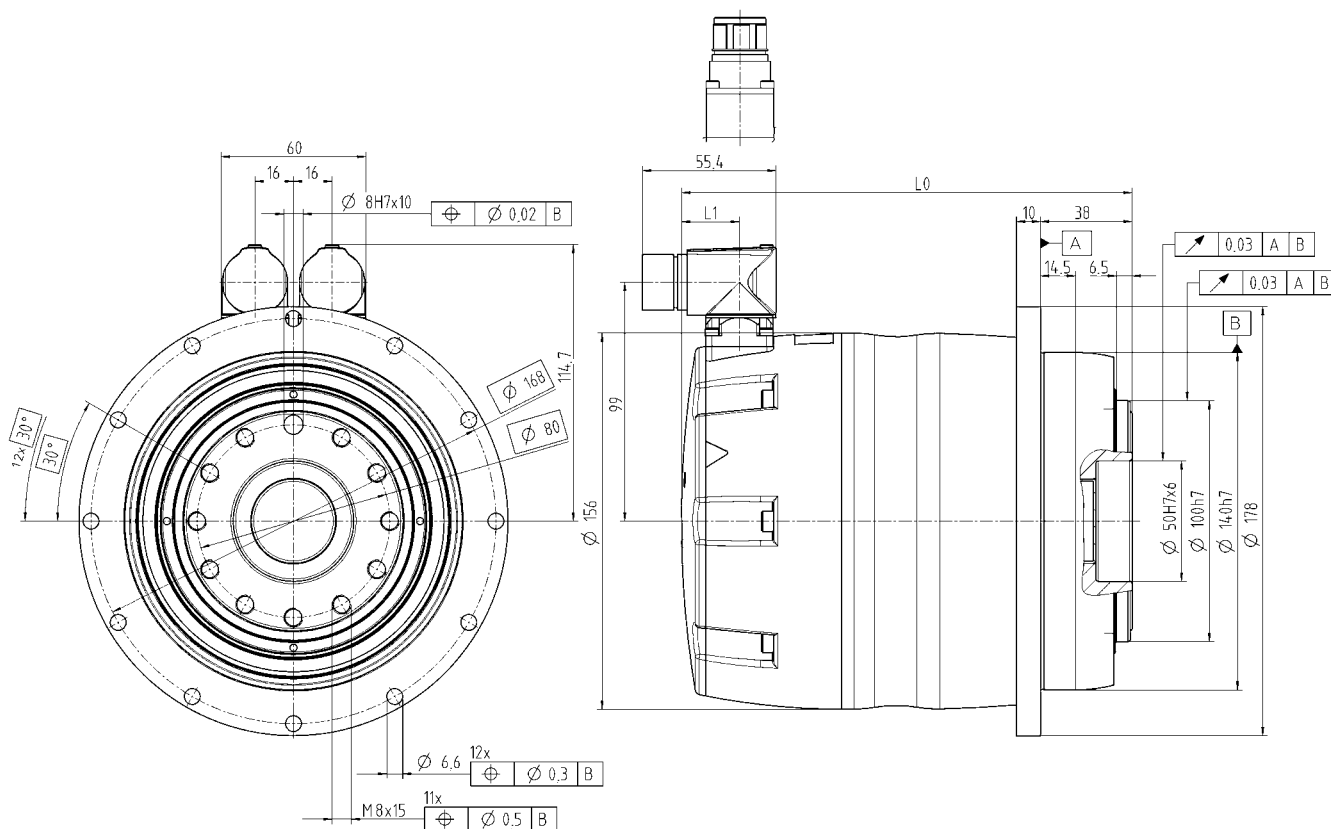

Electrical connection: Integral sockets, straight or angled, manufactured by Intercontec, SpeedTEC model, series A and B, size 1

without brake

Ratio	Motor feedback	Length L0 [mm]	Length L1 [mm]
i = 16/21/31	Resolver	232	24
	Hiperface	253	45
	EnDat	257	49
i = 61/64/91	Resolver	187	24
	Hiperface	208	45
	EnDat	212	49

with brake

Ratio	Motor feedback	Length L0 [mm]	Length L1 [mm]
i = 16/21/31	Resolver	256	24
	Hiperface	278	45
	EnDat	281	49
i = 61/64/91	Resolver	211	24
	Hiperface	233	45
	EnDat	236	49

TPM+ dynamic 110

Ratio	i	16		21		31		61		64		91	
		320	560	320	560	320	560	320	560	320	560	320	560
Intermediate circuit voltage	U_D V DC												
Max. acceleration torque at output (max. 1000 cycles per hour)	T_{2B} Nm	660		867		1279		1300		1300		1300	
Static output torque	T_{20} Nm	208		278		419		700		700		700	
Brake holding torque at output, 100°C	T_{2BR} Nm	208		273		403		793		832		1183	
Max. speed	n_{2max} rpm	231	312	176	238	119	161	82		78		55	
Speed limit for T_{2B}	n_{2B} rpm	118	206	90	157	61	106	59		56		39	
Max. acceleration torque of motor	T_{Mmax} Nm	43.9		43.9		43.9		28.9		28.9		28.9	
Max. acceleration current of motor	I_{maxdyn} A _{eff}	70.0		70.0		70.0		70.0	40.0	70.0	40.0	70.0	40.0
Static motor current	I_0 A _{eff}	16.7		16.7		16.7		23.7	13.7	23.7	13.7	23.7	13.7
Moment of inertia (on motor shaft, without brake, with resolver)	J_1 kgm ² ·10 ⁻⁴	13.14		13.14		12.84		8.89		8.83		8.83	
Torsional backlash	j_t arcmin	Standard ≤ 3 / Reduced ≤ 1											
Torsional rigidity	C_t Nm/arcmin	-		465		440		415		-		360	
Tilting rigidity	C_K Nm/arcmin	1452											
Max. axial force	F_{Amax} N	10050											
Max. tilting torque (distance from point of rotation to output flange 106.8 mm)	M_{Kmax} Nm	3280											
Weight (with resolver, without brake)	m kg	37.1						35.9					
Operating noise (measured at motor speed of 3000 rpm)	L_{PA} dB(A)	≤ 72											
Max. permitted housing temperature	°C	+90											
Ambient temperature	°C	0 to +40											
Protection class		IP 65											
Mounting position		Any											
Lubrication		Synthetic oil, lubricated for life											
Insulating material class		F											
Paint		Metallic blue 250 and natural cast aluminum											

Tolerances T, I and n: Maximum +/- 10%.

Please refer to the instructions and graphic illustration of the speed and torque values in the chapter "Information".

View A

View B

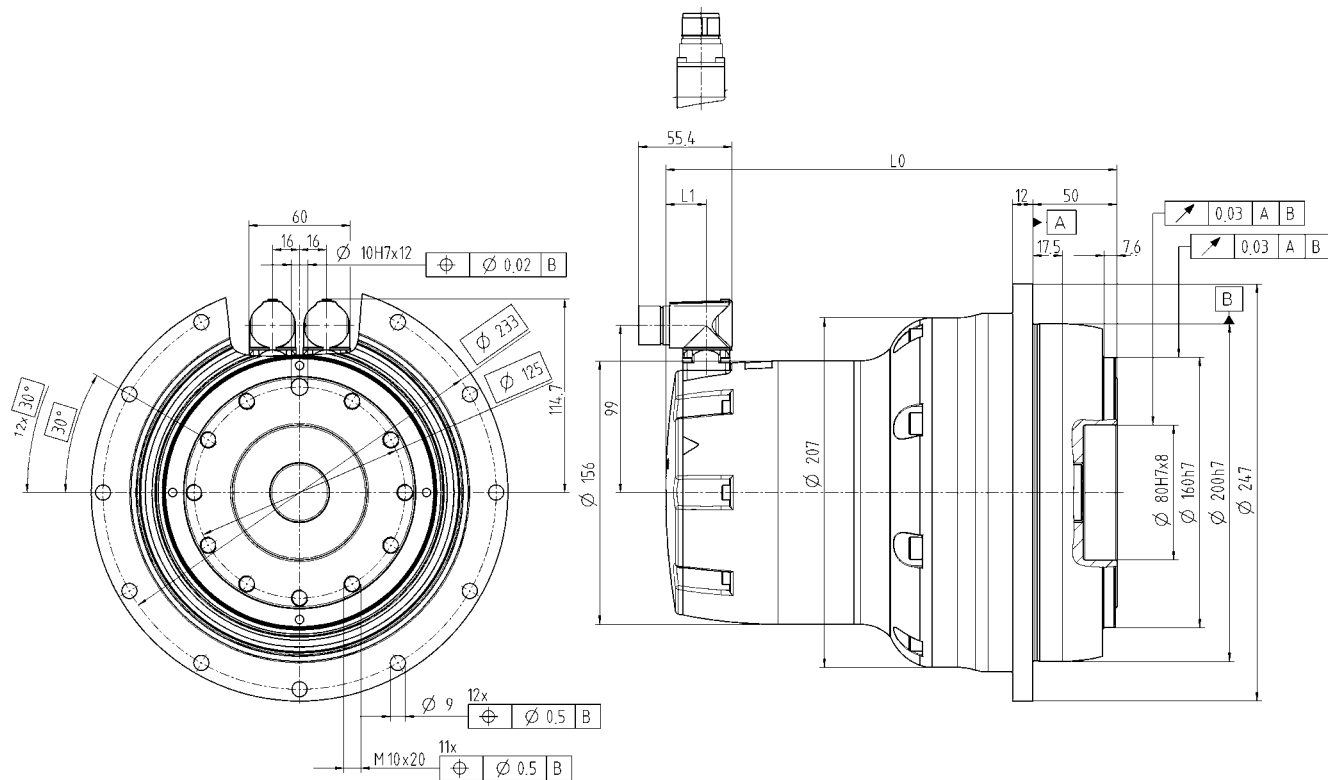

Electrical connection: Integral sockets, straight or angled, manufactured by Intercontec, SpeedTEC model, series A and B, size 1

without brake

Ratio	Motor feedback	Length L0 [mm]	Length L1 [mm]
i = 16/21/31	Resolver	283	24
	Hiperface	304	45
	EnDat	308	49
i = 61/64/91	Resolver	268	24
	Hiperface	289	45
	EnDat	293	49

with brake

Ratio	Motor feedback	Length L0 [mm]	Length L1 [mm]
i = 16/21/31	Resolver	307	24
	Hiperface	328	45
	EnDat	332	49
i = 61/64/91	Resolver	292	24
	Hiperface	313	45
	EnDat	317	49

Servo actuators **TPM+ high torque**

Servo actuators TPM+ high torque

Uncompromising workers!

This outstanding motor gearhead unit puts you even further ahead.



Unyielding strength!





TPM+ high torque: This high-torque actuator does not flinch at even the most complex challenges. It is capable of resisting almost any externally applied forces without yielding. Thanks to its unbending strength, this muscle-packed machine requires no assistance to handle even the heaviest loads. The high torque model excels with up to 90% higher torsional rigidity compared to standard gearheads.



Applications

The TPM+ high torque enhances productivity and precision of processing machines and swivel axes. Its high torsional rigidity and impressive torque reserves in the event of disturbing forces guarantee absolutely stable motion control. The outcome: exceptionally high and resistant dynamics no matter how tough the task.

Processing machine

Size TPM+ high torque	Length from	Max. acceleration torque	Max. power
010 	183 mm	230 Nm	4.5 kW
025 	219 mm	530 Nm	9.8 kW
050 	279 mm	950 Nm	15.6 kW
110 	328 mm	3100 Nm	49.9 kW

Stronger ...

More torque (50%) and higher operability. The increased rigidity of the drive train provides better power transmission, leading to higher acceleration and shorter cycle times. This combination of strength and effectiveness pays dividends.

More compact ...

The significant (40%) reduction in length and weight gives you greater mounting flexibility. The seamless integration of motor and gearhead and the efficient coupling of the motor instruments lay the foundation for the TPM+ high torque's success.

More torsionally rigid ...

The additional planet in the gear set permits a significant increase in torsional rigidity. You profit from even better control response and improved precision. These are powerful success factors that can strengthen your business.

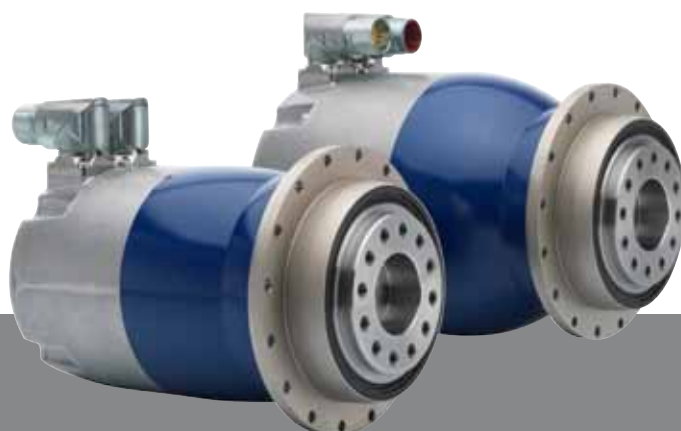

TPM+ high torque

TPM+ high torque 010

Ratio	i		22		27.5		38.5		55		88		110		154		220	
Intermediate circuit voltage	U_D	V DC	560	320	560	320	560	320	560	320	560	320	560	320	560	320	560	320
Max. acceleration torque at output (max. 1000 cycles per hour)	T_{2B}	Nm	230															
Static output torque	T_{20}	Nm	79		99		139		110		180		180		180		180	
Brake holding torque at output, 100°C	T_{2BR}	Nm	99		124		173		248 ¹⁾		396 ¹⁾		495 ¹⁾		277 ¹⁾		396 ¹⁾	
Max. speed	n_{2max}	rpm	220		176		126		88		55		44		31		22	
Speed limit for T_{2B}	n_{2B}	rpm	187		163		126		88		55		44		31		22	
Max. acceleration torque of motor	T_{Mmax}	Nm	12		12		12		12		12		12		4.4		4.4	
Max. acceleration current of motor	I_{maxdyn}	A_{eff}	17	29.4	17	29.4	17	29.4	17	29.4	17	29.4	17	29.4	6	10.4	6	10.4
Static motor current	I_0	A_{eff}	5	8.6	5	8.6	5	8.6	5	8.6	5	8.6	5	8.6	1.9	3.3	1.9	3.3
Moment of inertia (on motor shaft, without brake, with resolver)	J_i	$kgm^2 \cdot 10^{-4}$	2.06		2.03		2.01		1.99		2.01		2		0.68		0.67	
Torsional backlash	j_t	arcmin	≤ 1															
Torsional rigidity	C_t	Nm/arcmin	43						42									
Tilting rigidity	C_K	Nm/arcmin	225															
Max. axial force	F_{Amax}	N	2150															
Max. tilting torque (distance from point of rotation to output flange 82.7 mm)	M_{Kmax}	Nm	400															
Weight (with resolver, without brake)	m	kg	7.6						8.0				6.5					
Operating noise (measured at motor speed of 3000 rpm)	L_{PA}	dB(A)	≤ 60															
Max. permitted housing temperature		°C	90															
Ambient temperature		°C	0 to +40															
Protection class			IP65															
Mounting position			Any															
Lubrication			Synthetic oil, lubricated for life															
Insulating material class			F															
Paint			Metallic blue 250 and natural cast aluminum															

Tolerances T, I and n: Maximum +/- 10%.

¹⁾ greater than T_{2B} of gearhead. In an emergency, can be used approx. 1000 times while the motor is rotating.

Please refer to the instructions and graphic illustration of the speed and torque values in the chapter "Information".

View A

View B

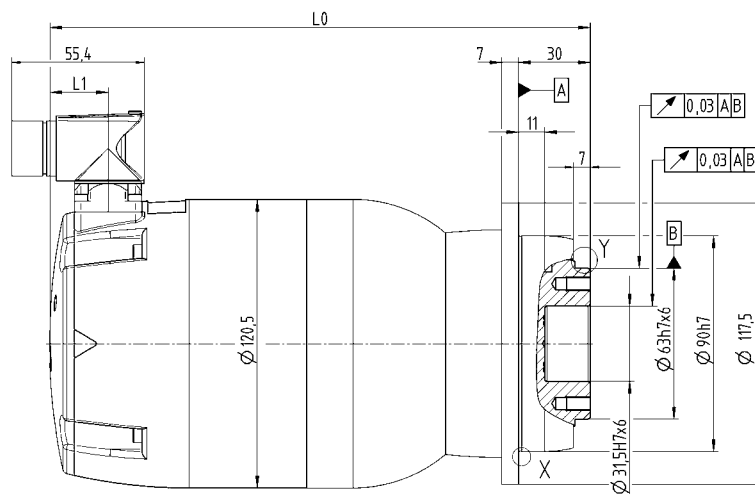
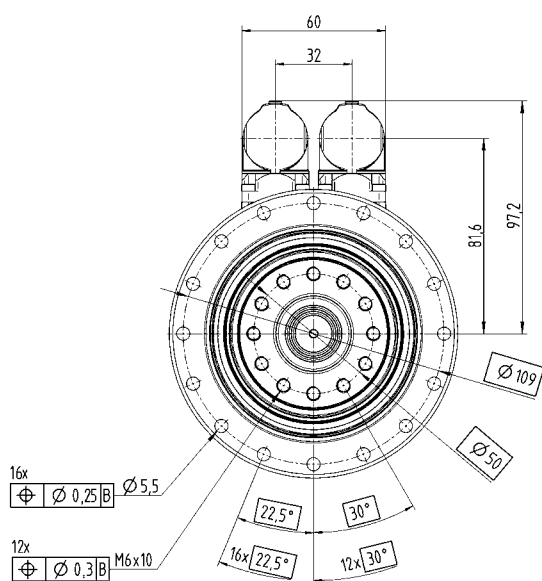

Electrical connection: Integral sockets, straight or angled, manufactured by Intercontec, Speedtec model, series A and B, size 1

without brake

Ratio	Motor feedback	Length L0 [mm]	Length L1 [mm]
i = 22/27,5/38,5/55	Resolver	207	24
	Hiperface	228	45
	EnDat	232	49
i = 88/110	Resolver	213	24
	Hiperface	234	45
	EnDat	238	49
i = 154/220	Resolver	183	24
	Hiperface	204	45
	EnDat	208	49

with brake

Ratio	Motor feedback	Length L0 [mm]	Length L1 [mm]
i = 22/27,5/38,5/55	Resolver	226	24
	Hiperface	247	45
	EnDat	251	49
i = 88/110	Resolver	232	24
	Hiperface	253	45
	EnDat	257	49
i = 154/220	Resolver	202	24
	Hiperface	223	45
	EnDat	227	49

TPM+ high torque 025

Ratio	i	22		27.5		38.5		55		66		88		110		154		220			
		320	560	320	560	320	560	320	560	320	560	320	560	320	560	320	560	320	560		
Intermediate circuit voltage	U _D	V DC																			
Max. acceleration torque at output (max. 1000 cycles per hour)	T _{2B}	Nm	530		530		530		530		480		480		480		480		480		
Static output torque	T ₂₀	Nm	232		291		375		375		260		260		260		260		260		
Brake holding torque at output, 100°C	T _{2BR}	Nm	286		358		500		715 ¹⁾		297		396		495 ¹⁾		693 ¹⁾		990 ¹⁾		
Max. speed	n _{2max}	rpm	220		176		126		88		73		55		44		31		22		
Speed limit for T _{2B}	n _{2B}	rpm	177		155		122		88		70		55		44		31		22		
Max. acceleration torque of motor	T _{Mmax}	Nm	28,9		28,9		28,9		28,9		12		12		12		12		12		
Max. acceleration current of motor	I _{maxdyn}	A _{eff}	70	40	70	40	70	40	70	40	29.4	17	29.4	17	29.4	17	29.4	17	29.4	17	
Static motor current	I ₀	A _{eff}	22.7	13.1	22.7	13.1	22.7	13.1	22.7	13.1	10.0	5.8	10.0	5.8	10.0	5.8	10.0	5.8	10.0	5.8	
Moment of inertia (on motor shaft, without brake, with resolver)	J _i	kgm ² ·10 ⁻⁴	9.01		8.83		8.74		8.69		2.03		1.96		1.93		1.91		1.89		
Torsional backlash	j _t	arcmin	≤1																		
Torsional rigidity	C _t	Nm/arcmin	105		105		105		100		95		95		95		95		95		
Tilting rigidity	C _K	Nm/arcmin	550																		
Max. axial force	F _{Amax}	N	4150																		
Max. tilting torque (distance from point of rotation to output flange 94.5 mm)	M _{Kmax}	Nm	550																		
Weight (with resolver, without brake)	m	kg	14.8							10											
Operating noise (measured at motor speed of 3000 rpm)	L _{PA}	dB(A)	≤ 62																		
Max. permitted housing temperature		°C	90																		
Ambient temperature		°C	0 to +40																		
Protection class			IP65																		
Mounting position			Any																		
Lubrication			Synthetic oil, lubricated for life																		
Insulating material class			F																		
Paint			Metallic blue 250 and natural cast aluminum																		

Tolerances T, I and n: Maximum +/- 10%.

¹⁾ greater than T_{2B} of gearhead. In an emergency, can be used approx. 1000 times while the motor is rotating.

Please refer to the instructions and graphic illustration of the speed and torque values in the chapter "Information".

View A

View B

Ratio
22 to 55

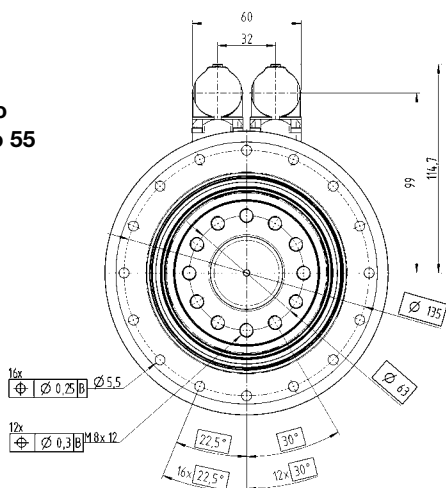

Ratio
66 to 220

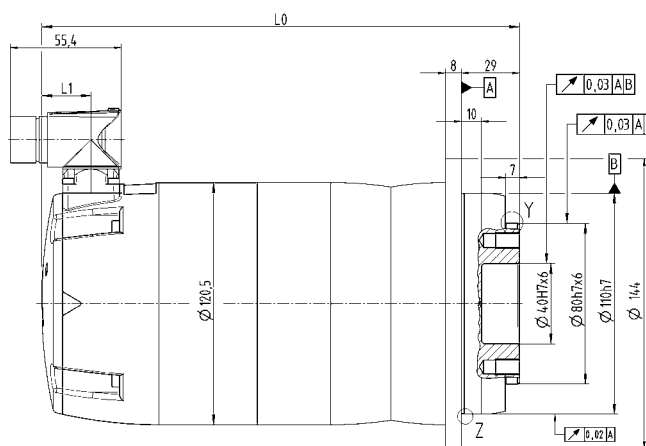
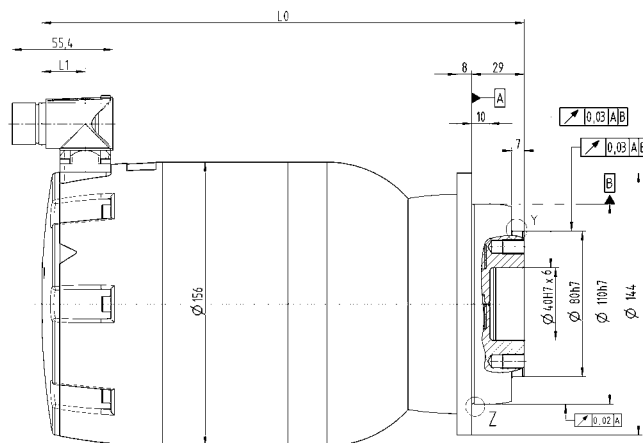
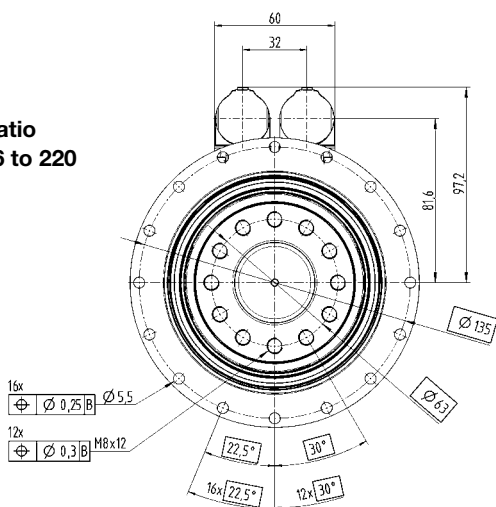

Electrical connection: Integral sockets, straight or angled, manufactured by Intercontec, SpeedTEC model, series A and B, size 1

without brake

Ratio	Motor feedback	Length L0 [mm]	Length L1 [mm]
i = 22/27,5/38,5/55	Resolver	242	24
	Hiperface	263	45
	EnDat	267	49
i = 66/88/110/154/220	Resolver	219	24
	Hiperface	240	45
	EnDat	244	49

with brake

Ratio	Motor feedback	Length L0 [mm]	Length L1 [mm]
i = 22/27,5/38,5/55	Resolver	266	24
	Hiperface	287	45
	EnDat	291	49
i = 66/88/110/154/220	Resolver	238	24
	Hiperface	259	45
	EnDat	263	49

TPM+ high torque 050

Ratio	i	22	27.5	38.5	55	66	88	110	154	220
Intermediate circuit voltage	U_D V DC	560								
Max. acceleration torque at output (max. 1000 cycles per hour)	T_{2B} Nm	950								
Static output torque	T_{20} Nm	406	513	650	675	675	675	675	675	675
Brake holding torque at output, 100°C	T_{2BR} Nm	506	632	886	1265 ¹⁾	858	1144 ¹⁾	1430 ¹⁾	2002 ¹⁾	2375 ¹⁾
Max. speed	n_{2max} rpm	205	164	117	82	73	55	44	31	22
Speed limit for T_{2B}	n_{2B} rpm	156	136	108	82	69	55	44	31	22
Max. acceleration torque of motor	T_{Mmax} Nm	56.6	56.6	56.6	56.6	28.9	28.9	28.9	28.9	28.9
Max. acceleration current of motor	I_{maxdyn} A _{eff}	63.5	63.5	63.5	63.5	40	40	40	40	40
Static motor current	I_0 A _{eff}	17.9	17.9	17.9	17.9	12.6	12.6	12.6	12.6	12.6
Moment of inertia (on motor shaft, without brake, with resolver)	J_i kgm ² ·10 ⁻⁴	23.8	23.35	22.99	22.81	9.23	9.04	8.84	8.74	8.69
Torsional backlash	j_t arcmin	≤ 1								
Torsional rigidity	C_t Nm/arcmin	220	220	220	220	205	205	205	205	205
Tilting rigidity	C_K Nm/arcmin	560								
Max. axial force	F_{Amax} N	6130								
Max. tilting torque (distance from point of rotation to output flange 81.2 mm)	M_{Kmax} Nm	1335								
Weight (with resolver, without brake)	m kg	25.3				21.8				
Operating noise (measured at motor speed of 3000 rpm)	L_{PA} dB(A)	≤ 64								
Max. permitted housing temperature	°C	90								
Ambient temperature	°C	0 to +40								
Protection class		IP65								
Mounting position		Any								
Lubrication		Synthetic oil, lubricated for life								
Insulating material class		F								
Paint		Metallic blue 250 and natural cast aluminum								

Tolerances T, I and n: Maximum +/- 10%.

¹⁾ greater than T_{2B} of gearhead. In an emergency, can be used approx. 1000 times while the motor is rotating.

Please refer to the instructions and graphic illustration of the speed and torque values in the chapter "Information".

TPM+ high torque 110

Ratio	i		22	27.5	38.5	55	66	88	110	154	220
Intermediate circuit voltage	U_D	V DC	560								
Max. acceleration torque at output (max. 1000 cycles per hour)	T_{2B}	Nm	3100	3100	3100	2000	2600	2600	2600	2600	2600
Static output torque	T_{20}	Nm	1368	1600	1650	1400	1600	1750	1750	1750	1750
Brake holding torque at output, 100°C	T_{2BR}	Nm	1584	1980	2772	3960 ¹⁾	4752 ¹⁾	6336 ¹⁾	2530	3542 ¹⁾	5060 ¹⁾
Max. speed	n_{2max}	rpm	189	151	108	75	63	47	41	29	20
Speed limit for T_{2B}	n_{2B}	rpm	154	135	106	75	63	47	38	29	20
Max. acceleration torque of motor	T_{Mmax}	Nm	164.5	164.5	164.5	164.5	88	88	56.6	56.6	56.6
Max. acceleration current of motor	I_{maxdyn}	A_{eff}	160	160	160	160	100	100	63.5	63.5	63.5
Static motor current	I_0	A_{eff}	53.7	53.7	53.7	53.7	40.9	40.9	20.5	20.5	20.5
Moment of inertia (on motor shaft, without brake, with resolver)	J_i	$kgm^2 \cdot 10^{-4}$	220.4	218.9	217.6	216.9	111.8	108.2	2.9	22.5	22.3
Torsional backlash	j_t	arcmin	≤ 1								
Torsional rigidity	C_t	Nm/arcmin	730	725	715	670	650	650	650	650	650
Tilting rigidity	C_K	Nm/arcmin	1452								
Max. axial force	F_{Amax}	N	10050								
Max. tilting torque (distance from point of rotation to output flange 106.8 mm)	M_{Kmax}	Nm	3280								
Weight (with resolver, without brake)	m	kg	76.8				63.8			45.5	
Operating noise (measured at motor speed of 3000 rpm)	L_{PA}	dB(A)	≤ 66								
Max. permitted housing temperature		°C	90								
Ambient temperature		°C	0 to +40								
Protection class			IP65								
Mounting position			Any								
Lubrication			Synthetic oil, lubricated for life								
Insulating material class			F								
Paint			Metallic blue 250 and natural cast aluminum								

Tolerances T, I and n: Maximum +/- 10%.

¹⁾ greater than T_{2B} of gearhead. In an emergency, can be used approx. 1000 times while the motor is rotating.

Please refer to the instructions and graphic illustration of the speed and torque values in the chapter "Information".

Servo actuators **TPM+ power**

TPM+ power servo actuators

Generate more power!

With durable motor gearhead
designed to tackle any application.



A real power pack!

Three attributes that characterize our new TPM+ power drive unit. Powerful: due to its dynamic, high-torque synchronous servo motors. Compact: due to the space-optimized design of motor and gearhead with significantly reduced length. Quiet: due to the proven helical-toothed gearhead. TPM+ power: A real power pack for high-torque applications with high control accuracy.



Processing



Automation

Source: MAKA

Applications

The new TPM+ power drive unit demonstrates its superiority in highly dynamic linear applications with rack and pinions or spindles as well as in rotary movements that generate high masses and disturbing forces. New products for automation and efficient processing.

Size TPM+ power	Length from	Max. acceleration torque	Max. power
004 	149 mm	50 Nm	1.4 kW
010 	175 mm	130 Nm	4.7 kW
025 	197 mm	380 Nm	10.6 kW
050 	236 mm	750 Nm	16.5 kW
110 	307 mm	1600 Nm	32.0 kW

Stronger ...

More torque, high capability. A perfect combination of motors and efficient planetary gearheads makes a mockery of even the most difficult motion applications.

More compact ...

40 percent more compact due to the seamless integration of motor and gearhead as well as efficient attachment of motor instruments. Shorter installation length for greater flexibility when mounting.

Quieter ...

Helical-toothed precision planetary gearheads for extremely quiet low-vibration operation reduce operating noise to very low levels.



TPM+ power

TPM+ power 004 1-stage

Ratio	i	4		5		7		10		
Intermediate circuit voltage	U_D	V DC	320	560	320	560	320	560	320	560
Max. acceleration torque at output (max. 1000 cycles per hour)	T_{2B}	Nm	15		18		26		26	
Static output torque	T_{20}	Nm	4		6		8		12	
Brake holding torque at output, 100°C	T_{2BR}	Nm	4		6		8		11	
Max. speed	n_{2max}	rpm	1500		1200		857		600	
Speed limit for T_{2B}	n_{2B}	rpm	1040		830		590		460	
Max. acceleration torque of motor	T_{Mmax}	Nm	3.8		3.8		3.8		3.8	
Max. acceleration current of motor	I_{maxdyn}	A_{eff}	9.0	5.2	9.0	5.2	9.0	5.2	9.0	5.2
Static motor current	I_0	A_{eff}	2.7	1.6	2.7	1.6	2.7	1.6	2.7	1.6
Moment of inertia (on motor shaft, without brake, with resolver)	J_1	$kgm^2 \cdot 10^{-4}$	0.39		0.36		0.33		0.31	
Torsional backlash	j_t	arcmin	Standard ≤ 4 / Reduced ≤ 2							
Torsional rigidity	C_t	Nm/arcmin	12		12		11		8	
Tilting rigidity	C_K	Nm/arcmin	-							
Max. axial force	F_{Amax}	N	1630							
Max. tilting torque (distance from point of rotation to output flange 57.6 mm)	M_{Kmax}	Nm	110							
Weight (with resolver, without brake)	m	kg	3.6							
Operating noise (measured at motor speed of 3000 rpm)	L_{PA}	dB(A)	≤ 58							
Max. permitted housing temperature		°C	+90							
Ambient temperature		°C	0 to +40							
Protection class			IP 65							
Mounting position			Any							
Lubrication			Synthetic oil, lubricated for life							
Insulating material class			F							
Paint			Metallic blue 250 and natural cast aluminum							

Tolerances T, I and n: Maximum +/- 10%.

Please refer to the instructions and graphic illustration of the speed and torque values in the chapter "Information".

View A

View B

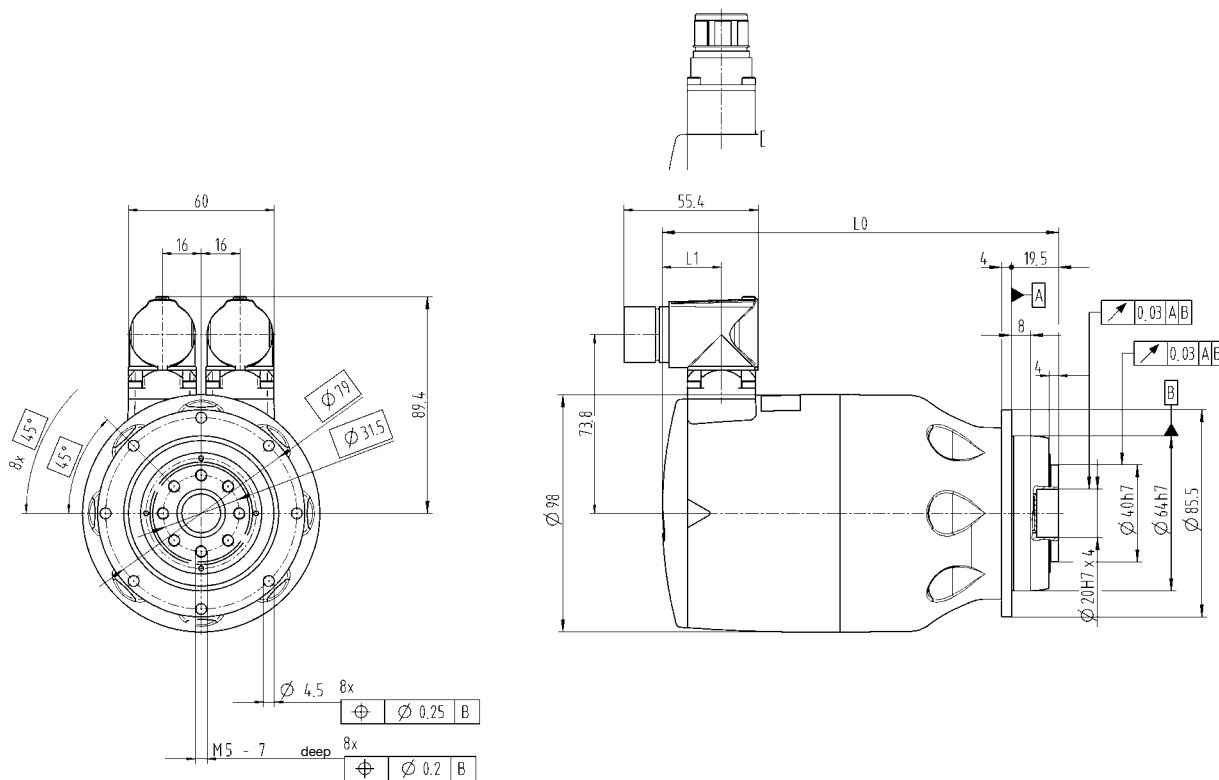

Electrical connection: Integral sockets, straight or angled, manufactured by Intercontec, SpeedTEC model, series A and B, size 1

without brake

Ratio	Motor feedback	Length L0 [mm]	Length L1 [mm]
i = 4, 5, 7, 10	Resolver	164	24
	Hiperface	185	45
	EnDat	189	49

with brake

Ratio	Motor feedback	Length L0 [mm]	Length L1 [mm]
i = 4, 5, 7, 10	Resolver	184	24
	Hiperface	205	45
	EnDat	209	49

TPM+ power 004 2-stage

Ratio	i	16		20		25		28		35		40		50		70		100		
		320	560	320	560	320	560	320	560	320	560	320	560	320	560	320	560	320	560	
Intermediate circuit voltage	U _D	V DC																		
Max. acceleration torque at output (max. 1000 cycles per hour)	T _{2B}	Nm	50		50		50		50		50		50		50		50		35	
Static output torque	T ₂₀	Nm	18		23		28		32		40		24		30		40		18	
Brake holding torque at output, 100°C	T _{2BR}	Nm	18		22		28		31		38		44		55 ¹⁾		77 ¹⁾		110 ¹⁾	
Max. speed	n _{2max}	rpm	375		300		240		214		171		150		120		86		60	
Speed limit for T _{2B}	n _{2B}	rpm	260		230		200		185		158		144		120		86		60	
Max. acceleration torque of motor	T _{Mmax}	Nm	3.8										1.9							
Max. acceleration current of motor	I _{maxdyn}	A _{eff}	9.0	5.2	9.0	5.2	9.0	5.2	9.0	5.2	9.0	5.2	5.2	3.0	5.2	3.0	5.2	3.0	5.2	3.0
Static motor current	I ₀	A _{eff}	2.7	1.6	2.7	1.6	2.7	1.6	2.7	1.6	2.7	1.6	1.7	1.0	1.7	1.0	1.7	1.0	1.7	1.0
Moment of inertia (on motor shaft, without brake, with resolver)	J _i	kgm ² ·10 ⁻⁴	0.32		0.31		0.31		0.31		0.31		0.16		0.16		0.16		0.16	
Torsional backlash	j _t	arcmin	Standard ≤ 4 / Reduced ≤ 2																	
Torsional rigidity	C _t	Nm/arcmin	12		12		12		12		12		11		12		11		8	
Tilting rigidity	C _K	Nm/arcmin	-																	
Max. axial force	F _{Amax}	N	1630																	
Max. tilting torque (distance from point of rotation to output flange 57.6 mm)	M _{Kmax}	Nm	110																	
Weight (with resolver, without brake)	m	kg	3.7										3.3							
Operating noise (measured at motor speed of 3000 rpm)	L _{PA}	dB(A)	≤ 58																	
Max. permitted housing temperature		°C	+90																	
Ambient temperature		°C	0 to +40																	
Protection class			IP 65																	
Mounting position			Any																	
Lubrication			Synthetic oil, lubricated for life																	
Insulating material class			F																	
Paint			Metallic blue 250 and natural cast aluminum																	

Tolerances T, I and n: Maximum +/- 10%.

¹⁾ greater than T_{2B} of the gearhead. In an emergency, can be used approx. 1000 times while the motor is rotating.

Please refer to the instructions and graphic illustration of the speed and torque values in the chapter "Information".

View A

View B

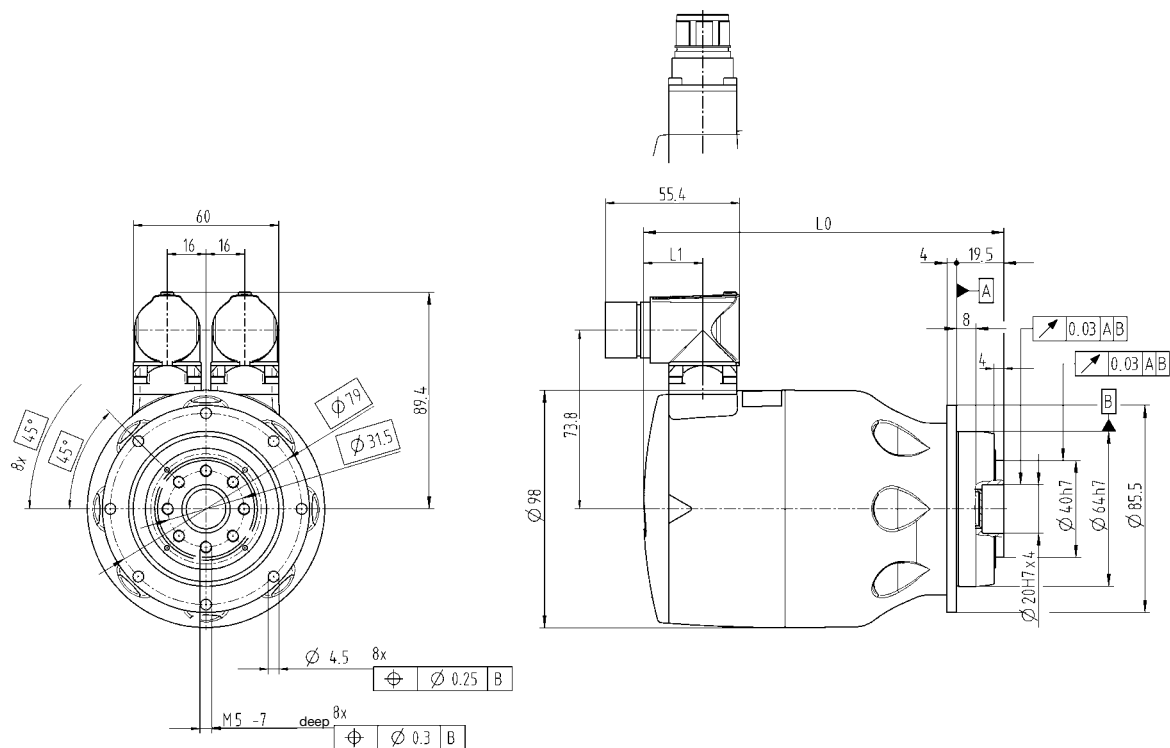

Electrical connection: Integral sockets, straight or angled, manufactured by Intercontec, SpeedTEC model, series A and B, size 1

without brake

Ratio	Motor feedback	Length L0 [mm]	Length L1 [mm]
i = 16, 20, 25, 28, 35	Resolver	164	24
	Hiperface	185	45
	EnDat	189	49
i = 40, 50, 70, 100	Resolver	149	24
	Hiperface	170	45
	EnDat	174	49

with brake

Ratio	Motor feedback	Length L0 [mm]	Length L1 [mm]
i = 16, 20, 25, 28, 35	Resolver	184	24
	Hiperface	205	45
	EnDat	209	49
i = 40, 50, 70, 100	Resolver	169	24
	Hiperface	190	45
	EnDat	194	49

TPM+ power 010 1-stage

Ratio	i	4		5		7		10		
Intermediate circuit voltage	U _D	V DC	320	560	320	560	320	560	320	560
Max. acceleration torque at output (max. 1000 cycles per hour)	T _{2B}	Nm	44		56		80		85	
Static output torque	T ₂₀	Nm	14		18		27		40	
Brake holding torque at output, 100°C	T _{2BR}	Nm	18		22		32		45	
Max. speed	n _{2max}	rpm	1500		1200		857		600	
Speed limit for T _{2B}	n _{2B}	rpm	980		780		560		440	
Max. acceleration torque of motor	T _{Mmax}	Nm	12.1		12.1		12.1		12.1	
Max. acceleration current of motor	I _{maxdyn}	A _{eff}	29.4	17.0	29.4	17.0	29.4	17.0	29.4	17.0
Static motor current	I ₀	A _{eff}	9.4	5.4	9.4	5.4	9.4	5.4	9.4	5.4
Moment of inertia (on motor shaft, without brake, with resolver)	J ₁	kgm ² ·10 ⁻⁴	2.38		2.22		2.08		2.00	
Torsional backlash	j _t	arcmin	Standard ≤ 3 / Reduced ≤ 1							
Torsional rigidity	C _t	Nm/arcmin	32		33		30		23	
Tilting rigidity	C _k	Nm/arcmin	225							
Max. axial force	F _{Amax}	N	2150							
Max. tilting torque (distance from point of rotation to output flange 82.7 mm)	M _{kmax}	Nm	270							
Weight (with resolver, without brake)	m	kg	7.2							
Operating noise (measured at motor speed of 3000 rpm)	L _{PA}	dB(A)	≤ 60							
Max. permitted housing temperature		°C	+90							
Ambient temperature		°C	0 to +40							
Protection class			IP 65							
Mounting position			Any							
Lubrication			Synthetic oil, lubricated for life							
Insulating material class			F							
Paint			Metallic blue 250 and natural cast aluminum							

Tolerances T, I and n: Maximum +/- 10%.

Please refer to the instructions and graphic illustration of the speed and torque values in the chapter "Information".

View A

View B

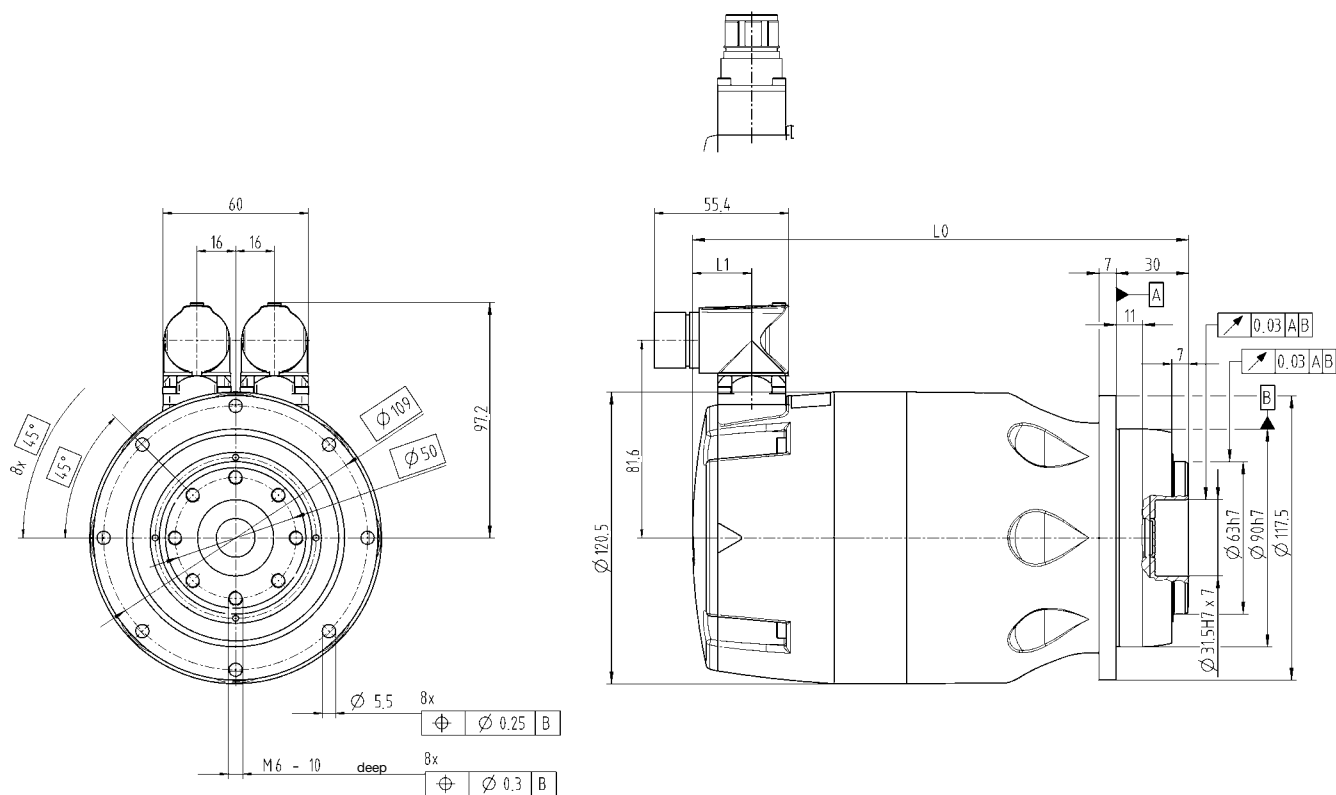

Electrical connection: Integral sockets, straight or angled, manufactured by Intercontec, SpeedTEC model, series A and B, size 1

without brake

Ratio	Motor feedback	Length L0 [mm]	Length L1 [mm]
i = 4, 5, 7, 10	Resolver	205	24
	Hiperface	226	45
	EnDat	230	49

with brake

Ratio	Motor feedback	Length L0 [mm]	Length L1 [mm]
i = 4, 5, 7, 10	Resolver	224	24
	Hiperface	245	45
	EnDat	249	49

TPM+ power 010 2-stage

Ratio	i	16		20		25		28		35		40		50		70		100		
		320	560	320	560	320	560	320	560	320	560	320	560	320	560	320	560	320	560	
Intermediate circuit voltage	U_D	V DC																		
Max. acceleration torque at output (max. 1000 cycles per hour)	T_{2B}	Nm	130		130		130		130		130		130		130		130		100	
Static output torque	T_{20}	Nm	66		84		90		90		90		48		62		86		60	
Brake holding torque at output, 100°C	T_{2BR}	Nm	72		90		112		126		158 ¹⁾		180 ¹⁾		225 ¹⁾		250 ¹⁾		180 ¹⁾	
Max. speed	n_{2max}	rpm	375		300		240		214		171		150		120		86		60	
Speed limit for T_{2B}	n_{2B}	rpm	280		240		200		185		158		100		88		70		55	
Max. acceleration torque of motor	T_{Mmax}	Nm	12.1		12.1		12.1		12.1		12.1		4.4		4.4		4.4		4.4	
Max. acceleration current of motor	I_{maxdyn}	A_{eff}	29.4	17.0	29.4	17.0	29.4	17.0	29.4	17.0	29.4	17.0	10.4	6.0	10.4	6.0	10.4	6.0	10.4	6.0
Static motor current	I_0	A_{eff}	9.4	5.4	9.4	5.4	9.4	5.4	9.4	5.4	9.4	5.4	3.2	1.9	3.2	1.9	3.2	1.9	3.2	1.9
Moment of inertia (on motor shaft, without brake, with resolver)	J_1	$kgm^2 \cdot 10^{-4}$	2.02		1.99		1.98		1.96		1.96		0.72		0.72		0.72		0.72	
Torsional backlash	j_t	arcmin	Standard ≤ 3 / Reduced ≤ 1																	
Torsional rigidity	C_t	Nm/arcmin	32		32		32		31		32		30		30		28		22	
Tilting rigidity	C_K	Nm/arcmin	225																	
Max. axial force	F_{Amax}	N	2150																	
Max. tilting torque (distance from point of rotation to output flange 82.7 mm)	M_{Kmax}	Nm	270																	
Weight (with resolver, without brake)	m	kg	7.4										6.0							
Operating noise (measured at motor speed of 3000 rpm)	L_{PA}	dB(A)	≤ 62																	
Max. permitted housing temperature		°C	+90																	
Ambient temperature		°C	0 to +40																	
Protection class			IP 65																	
Mounting position			Any																	
Lubrication			Synthetic oil, lubricated for life																	
Insulating material class			F																	
Paint			Metallic blue 250 and natural cast aluminum																	

Tolerances T, I and n: Maximum +/- 10%.

¹⁾ greater than T_{2B} of the gearhead. In an emergency, can be used approx. 1000 times while the motor is rotating.

Please refer to the instructions and graphic illustration of the speed and torque values in the chapter "Information".

View A

View B

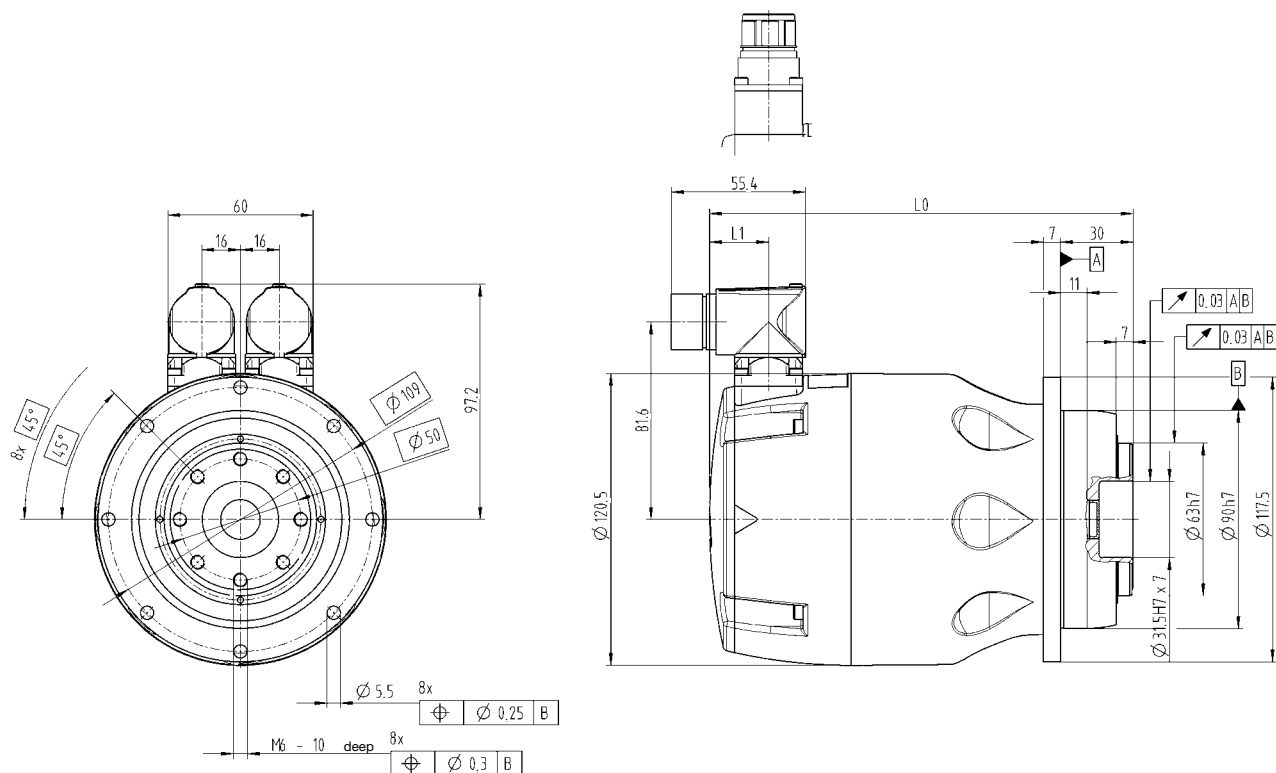

Electrical connection: Integral sockets, straight or angled, manufactured by Intercontec, SpeedTEC model, series A and B, size 1

without brake

Ratio	Motor feedback	Length L0 [mm]	Length L1 [mm]
i = 16, 20, 25, 28, 35	Resolver	205	24
	Hiperface	226	45
	EnDat	230	49
i = 40, 50, 70, 100	Resolver	175	24
	Hiperface	196	45
	EnDat	200	49

with brake

Ratio	Motor feedback	Length L0 [mm]	Length L1 [mm]
i = 16, 20, 25, 28, 35	Resolver	224	24
	Hiperface	245	45
	EnDat	249	49
i = 40, 50, 70, 100	Resolver	194	24
	Hiperface	215	45
	EnDat	219	49

TPM+ power 025 1-stage

Ratio	i	4		5		7		10		
Intermediate circuit voltage	U _D	V DC	320	560	320	560	320	560	320	560
Max. acceleration torque at output (max. 1000 cycles per hour)	T _{2B}	Nm	112		141		199		200	
Static output torque	T ₂₀	Nm	43		55		78		113	
Brake holding torque at output, 100°C	T _{2BR}	Nm	52		65		91		130	
Max. speed	n _{2max}	rpm	1500		1200		857		600	
Speed limit for T _{2B}	n _{2B}	rpm	900		720		520		420	
Max. acceleration torque of motor	T _{Mmax}	Nm	28.9		28.9		28.9		28.9	
Max. acceleration current of motor	I _{maxdyn}	A _{eff}	70	40	70	40	70	40	70	40
Static motor current	I ₀	A _{eff}	23.7	13.7	23.7	13.7	23.7	13.7	23.7	13.7
Moment of inertia (on motor shaft, without brake, with resolver)	J ₁	kgm ² ·10 ⁻⁴	9.98		9.50		9.07		8.84	
Torsional backlash	j _t	arcmin	Standard ≤ 3 / Reduced ≤ 1							
Torsional rigidity	C _t	Nm/arcmin	80		86		76		62	
Tilting rigidity	C _K	Nm/arcmin	550							
Max. axial force	F _{Amax}	N	4150							
Max. tilting torque (distance from point of rotation to output flange 94.5 mm)	M _{Kmax}	Nm	440							
Weight (with resolver, without brake)	m	kg	14.0							
Operating noise (measured at motor speed of 3000 rpm)	L _{PA}	dB(A)	≤ 64							
Max. permitted housing temperature		°C	+90							
Ambient temperature		°C	0 to +40							
Protection class			IP 65							
Mounting position			Any							
Lubrication			Synthetic oil, lubricated for life							
Insulating material class			F							
Paint			Metallic blue 250 and natural cast aluminum							

Tolerances T, I and n: Maximum +/- 10%.

Please refer to the instructions and graphic illustration of the speed and torque values in the chapter "Information".

View A

View B

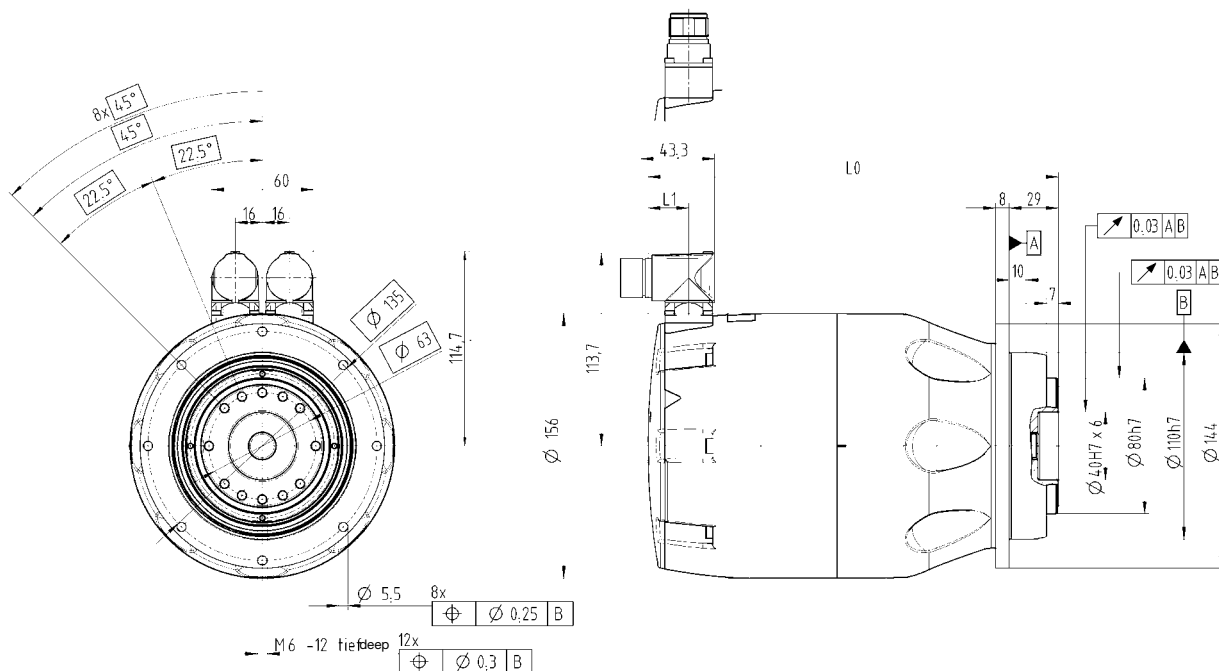

Electrical connection: Integral sockets, straight or angled, manufactured by Intercontec, SpeedTEC model, series A and B, size 1

without brake

Ratio	Motor feedback	Length L0 [mm]	Length L1 [mm]
i = 4, 5, 7, 10	Resolver	242	24
	Hiperface	263	45
	EnDat	267	49

with brake

Ratio	Motor feedback	Length L0 [mm]	Length L1 [mm]
i = 4, 5, 7, 10	Resolver	266	24
	Hiperface	287	45
	EnDat	291	49

TPM+ power 025 2-stage

Ratio	i	16		20		25		28		35		40		50		70		100	
		320	560	320	560	320	560	320	560	320	560	320	560	320	560	320	560	320	560
Intermediate circuit voltage	U_D V DC																		
Max. acceleration torque at output (max. 1000 cycles per hour)	T_{2B} Nm	350		350		380		350		380		305		380		330		265	
Static output torque	T_{20} Nm	181		210		200		210		220		113		142		200		120	
Brake holding torque at output, 100°C	T_{2BR} Nm	208		260		325		364 ¹⁾		455 ¹⁾		520 ¹⁾		625 ¹⁾		625 ¹⁾		600 ¹⁾	
Max. speed	n_{2max} rpm	375		300		240		214		171		150		120		86		60	
Speed limit for T_{2B}	n_{2B} rpm	260		220		185		170		140		90		70		65		50	
Max. acceleration torque of motor	T_{Mmax} Nm	28.9		28.9		28.9		28.9		28.9		7.8		7.8		7.8		7.8	
Max. acceleration current of motor	I_{maxdyn} A _{eff}	70	40	70	40	70	40	70	40	70	40	21.0	12.0	21.0	12.0	21.0	12.0	21.0	12.0
Static motor current	I_0 A _{eff}	23.7	13.7	23.7	13.7	23.7	13.7	23.7	13.7	23.7	13.7	6.9	4.0	6.9	4.0	6.9	4.0	6.9	4.0
Moment of inertia (on motor shaft, without brake, with resolver)	J_1 kgm ² ·10 ⁻⁴	8.94		8.83		8.81		8.72		8.71		2.48		2.48		2.48		2.47	
Torsional backlash	j_t arcmin	Standard ≤ 3 / Reduced ≤ 1																	
Torsional rigidity	C_t Nm/arcmin	81		81		83		80		82		76		80		71		60	
Tilting rigidity	C_K Nm/arcmin	550																	
Max. axial force	F_{Amax} N	4150																	
Max. tilting torque (distance from point of rotation to output flange 94.5 mm)	M_{Kmax} Nm	440																	
Weight (with resolver, without brake)	m kg	14.5										10.3							
Operating noise (measured at motor speed of 3000 rpm)	L_{PA} dB(A)	≤ 64																	
Max. permitted housing temperature	°C	+90																	
Ambient temperature	°C	0 to +40																	
Protection class		IP 65																	
Mounting position		Any																	
Lubrication		Synthetic oil, lubricated for life																	
Insulating material class		F																	
Paint		Metallic blue 250 and natural cast aluminum																	

Tolerances T, I and n: Maximum +/- 10%.

¹⁾ greater than T_{2B} of the gearhead. In an emergency, can be used approx. 1000 times while the motor is rotating.

Please refer to the instructions and graphic illustration of the speed and torque values in the chapter "Information".

View A

View B

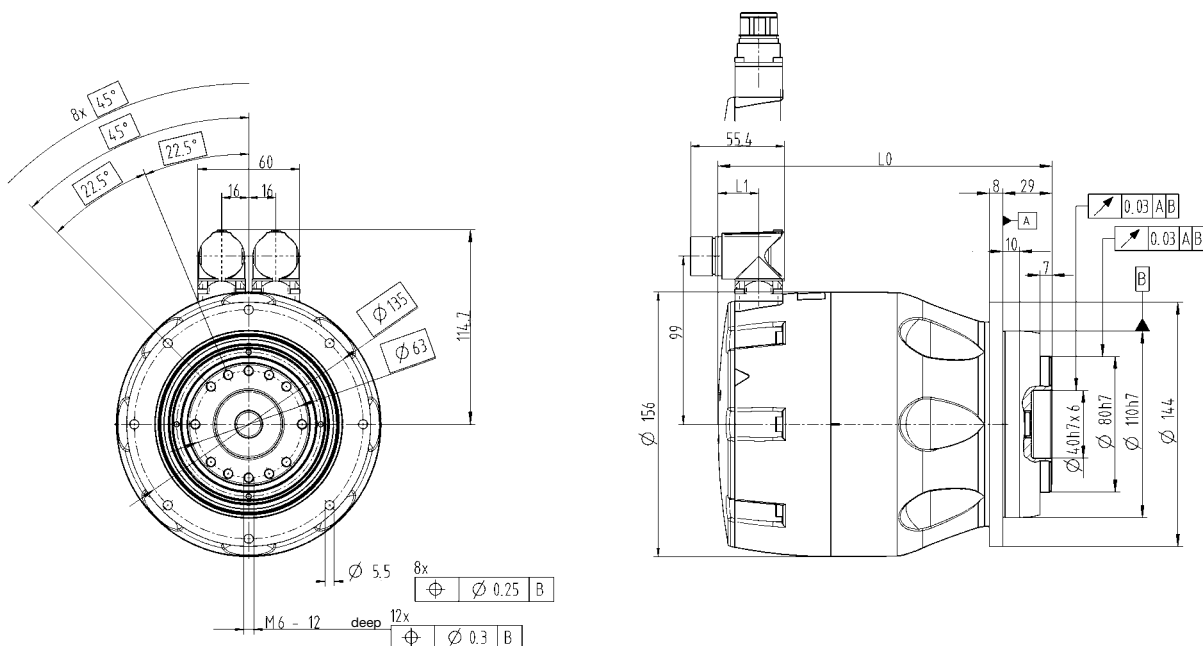

Electrical connection: Integral sockets, straight or angled, manufactured by Intercontec, SpeedTEC model, series A and B, size 1

without brake

Ratio	Motor feedback	Length L0 [mm]	Length L1 [mm]
i = 16, 20, 25, 28, 35	Resolver	242	24
	Hiperface	263	45
	EnDat	267	49
i = 40, 50, 70, 100	Resolver	197	24
	Hiperface	218	45
	EnDat	222	49

with brake

Ratio	Motor feedback	Length L0 [mm]	Length L1 [mm]
i = 16, 20, 25, 28, 35	Resolver	266	24
	Hiperface	287	45
	EnDat	291	49
i = 40, 50, 70, 100	Resolver	221	24
	Hiperface	242	45
	EnDat	246	49

TPM+ power 050 1-stage

Ratio	i		4	5	7	10
Intermediate circuit voltage	U_D	V DC	560	560	560	560
Max. acceleration torque at output (max. 1000 cycles per hour)	T_{2B}	Nm	221	278	340	350
Static output torque	T_{20}	Nm	72	91	130	188
Brake holding torque at output, 100°C	T_{2BR}	Nm	92	115	161	230
Max. speed	n_{2max}	rpm	1250	1000	714	500
Speed limit for T_{2B}	n_{2B}	rpm	780	620	450	370
Max. acceleration torque of motor	T_{Mmax}	Nm	56.6			
Max. acceleration current of motor	I_{maxdyn}	A_{eff}	63.5			
Static motor current	I_0	A_{eff}	19			
Moment of inertia (on motor shaft, without brake, with resolver)	J_1	$kgm^2 \cdot 10^{-4}$	26.4	24.8	23.3	22.5
Torsional backlash	j_t	arcmin	Standard ≤ 3 / Reduced ≤ 1			
Torsional rigidity	C_t	Nm/arcmin	190	187	159	123
Tilting rigidity	C_K	Nm/arcmin	560			
Max. axial force	F_{Amax}	N	6130			
Max. tilting torque (distance from point of rotation to output flange 81.2 mm)	M_{Kmax}	Nm	1335			
Weight (with resolver, without brake)	m	kg	23.6			
Operating noise (measured at motor speed of 3000 rpm)	L_{PA}	dB(A)	≤ 66			
Max. permitted housing temperature		°C	+90			
Ambient temperature		°C	0 to +40			
Protection class			IP 65			
Mounting position			Any			
Lubrication			Synthetic oil, lubricated for life			
Insulating material class			F			
Paint			Metallic blue 250 and natural cast aluminum			

Tolerances T, I and n: Maximum +/- 10%.

Please refer to the instructions and graphic illustration of the speed and torque values in the chapter "Information".

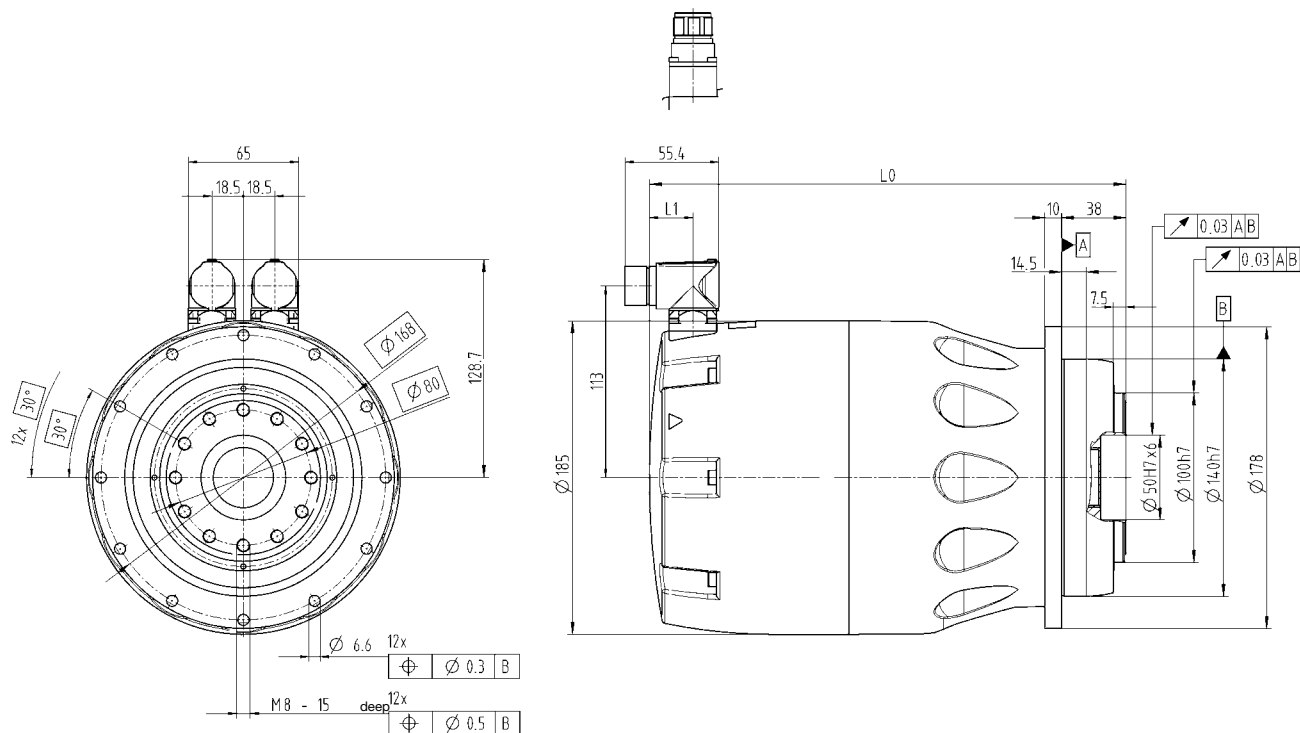

Electrical connection: Integral sockets, straight or angled, manufactured by Intercontec, SpeedTEC model, series A and B, size 1

without brake

Ratio	Motor feedback	Length L0 [mm]	Length L1 [mm]
i = 4, 5, 7, 10	Resolver	281	26
	Hiperface	306	50
	EnDat	306	50

with brake

Ratio	Motor feedback	Length L0 [mm]	Length L1 [mm]
i = 4, 5, 7, 10	Resolver	321	26
	Hiperface	346	50
	EnDat	346	50

TPM+ power 050 2-stage

Ratio	i		16	20	25	28	35	40	50	70	100	
Intermediate circuit voltage	U_D	V DC	560	560	560	560	560	560	560	560	560	
Max. acceleration torque at output (max. 1000 cycles per hour)	T_{2B}	Nm	750	750	750	750	750	607	750	700	540	
Static output torque	T_{20}	Nm	293	371	400	400	400	199	250	354	240	
Brake holding torque at output, 100°C	T_{2BR}	Nm	368	460	575	644	805 ¹⁾	920 ¹⁾	1150 ¹⁾	1250 ¹⁾	1100 ¹⁾	
Max. speed	n_{2max}	rpm	312	250	200	179	143	125	100	71	50	
Speed limit for T_{2B}	n_{2B}	rpm	210	180	155	145	125	90	80	65	50	
Max. acceleration torque of motor	T_{Mmax}	Nm	56.6					15.6				
Max. acceleration current of motor	I_{maxdyn}	A_{eff}	63.5					33				
Static motor current	I_D	A_{eff}	19					7,5				
Moment of inertia (on motor shaft, without brake, with resolver)	J_1	$kgm^2 \cdot 10^{-4}$	23.1	22.6	22.6	22.2	22.2	6.3	6.3	6.3	6.3	
Torsional backlash	j_t	arcmin	Standard ≤ 3 / Reduced ≤ 1									
Torsional rigidity	C_t	Nm/arcmin	180	185	180	180	175	175	175	145	115	
Tilting rigidity	C_K	Nm/arcmin	560									
Max. axial force	F_{Amax}	N	6130									
Max. tilting torque (distance from point of rotation to output flange 81.2 mm)	M_{Kmax}	Nm	1335									
Weight (with resolver, without brake)	m	kg	25.1					19.4				
Operating noise (measured at motor speed of 3000 rpm)	L_{PA}	dB(A)	≤ 65									
Max. permitted housing temperature		°C	+90									
Ambient temperature		°C	0 to +40									
Protection class			IP 65									
Mounting position			Any									
Lubrication			Synthetic oil, lubricated for life									
Insulating material class			F									
Paint			Metallic blue 250 and natural cast aluminum									

Tolerances T, I and n: Maximum +/- 10%.

¹⁾ greater than T_{2B} of the gearhead. In an emergency, can be used approx. 1000 times while the motor is rotating.

Please refer to the instructions and graphic illustration of the speed and torque values in the chapter "Information".

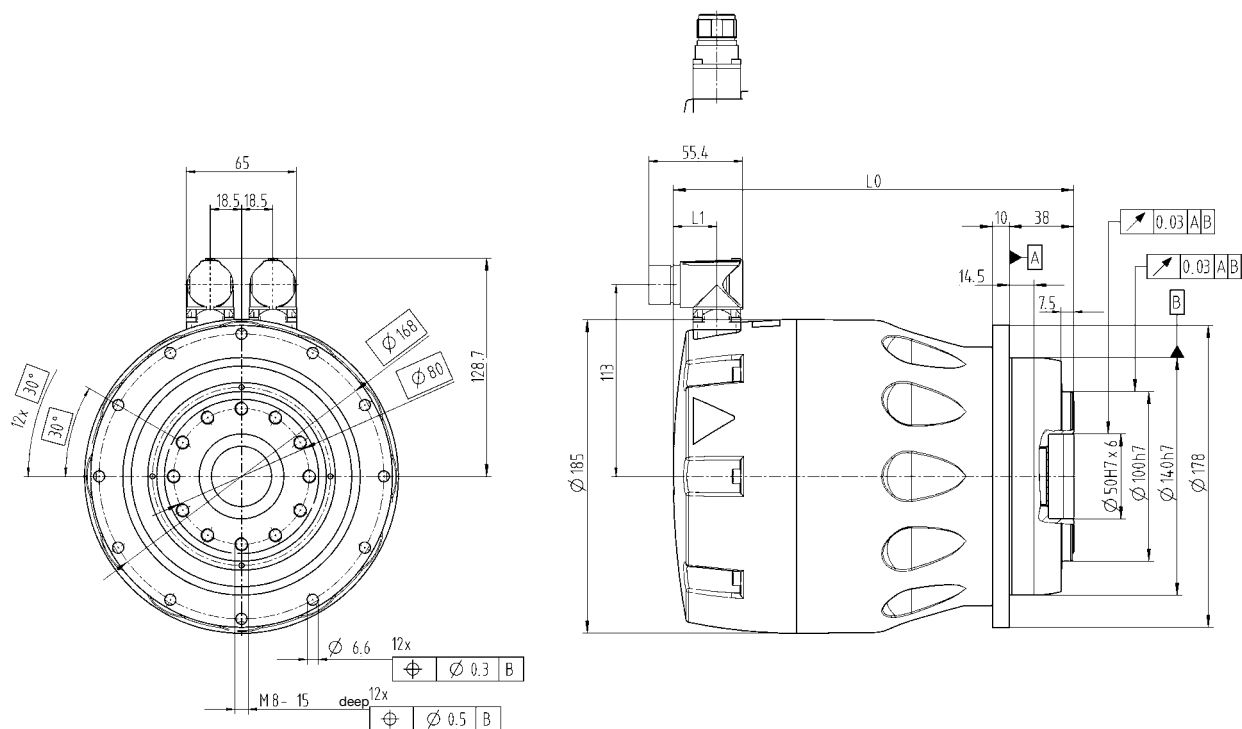

Electrical connection: Integral sockets, straight or angled, manufactured by Intercontec, SpeedTEC model, series A and B, size 1

without brake

Ratio	Motor feedback	Length L0 [mm]	Length L1 [mm]
i = 16, 20, 25, 28, 35	Resolver	281	26
	Hiperface	306	50
	EnDat	306	50
i = 40, 50, 70, 100	Resolver	236	26
	Hiperface	261	50
	EnDat	261	50

with brake

Ratio	Motor feedback	Length L0 [mm]	Length L1 [mm]
i = 16, 20, 25, 28, 35	Resolver	321	26
	Hiperface	346	50
	EnDat	346	50
i = 40, 50, 70, 100	Resolver	276	26
	Hiperface	301	50
	EnDat	301	50

TPM+ power 110 1-stage

Ratio	i		4	5	7	10
Intermediate circuit voltage	U_D	V DC	560	560	560	560
Max. acceleration torque at output (max. 1000 cycles per hour)	T_{2B}	Nm	340	428	603	555
Static output torque	T_{20}	Nm	136	172	246	356
Brake holding torque at output, 100°C	T_{2BR}	Nm	288	360	504	720 ¹⁾
Max. speed	n_{2max}	rpm	1050	840	643	450
Speed limit for T_{2B}	n_{2B}	rpm	950	750	540	450
Max. acceleration torque of motor	T_{Mmax}	Nm	88			
Max. acceleration current of motor	I_{maxdyn}	A_{eff}	100			
Static motor current	I_0	A_{eff}	38.6			
Moment of inertia (on motor shaft, without brake, with resolver)	J_1	$kgm^2 \cdot 10^{-4}$	142	132	123	118
Torsional backlash	j_t	arcmin	Standard ≤ 3 / Reduced ≤ 1			
Torsional rigidity	C_t	Nm/arcmin	610	610	550	445
Tilting rigidity	C_K	Nm/arcmin	1452			
Max. axial force	F_{Amax}	N	10050			
Max. tilting torque (distance from point of rotation to output flange 106.8 mm)	M_{Kmax}	Nm	3280			
Weight (with resolver, without brake)	m	kg	58.8			
Operating noise (measured at motor speed of 3000 rpm)	L_{PA}	dB(A)	≤ 70			
Max. permitted housing temperature		°C	+90			
Ambient temperature		°C	0 to +40			
Protection class			IP 65			
Mounting position			Any			
Lubrication			Synthetic oil, lubricated for life			
Insulating material class			F			
Paint			Metallic blue 250 and natural cast aluminum			

Tolerances T, I and n: Maximum +/- 10%.

¹⁾ greater than T_{2B} of gearhead. In an emergency, can be used approx. 1000 times while the motor is rotating.

Please refer to the instructions and graphic illustration of the speed and torque values in the chapter "Information".

View A

View B

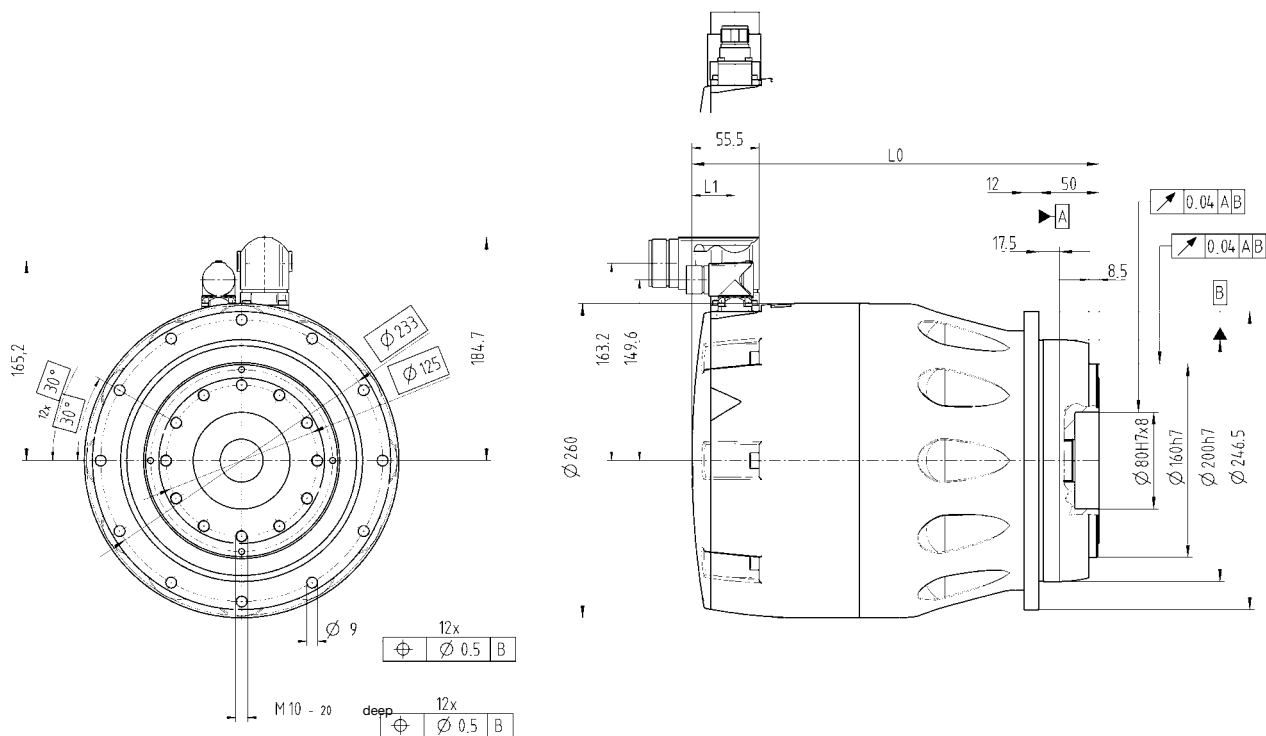

Electrical connection: Integral sockets, straight or angled, manufactured by Intercontec, SpeedTEC model, series A and B, size 1.5

without brake

Ratio	Motor feedback	Length L0 [mm]	Length L1 [mm]
i = 4, 5, 7, 10	Resolver	337	36
	Hiperface	361	60
	EnDat	361	60

with brake

Ratio	Motor feedback	Length L0 [mm]	Length L1 [mm]
i = 4, 5, 7, 10	Resolver	387	36
	Hiperface	411	60
	EnDat	411	60

TPM+ power 110 2-stage

Ratio	i		16	20	25	28	35	40	50	70	100
Intermediate circuit voltage	U_D	V DC	560	560	560	560	560	560	560	560	560
Max. acceleration torque at output (max. 1000 cycles per hour)	T_{2B}	Nm	1375	1600	1600	1600	1600	1600	1600	1600	1400
Static output torque	T_{20}	Nm	558	705	886	999	1250	794	997	900	800
Brake holding torque at output, 100°C	T_{2BR}	Nm	1152	1440	1800 ¹⁾	2016 ¹⁾	2520 ¹⁾	2750 ¹⁾	2750 ¹⁾	1750 ¹⁾	2500 ¹⁾
Max. speed	n_{2max}	rpm	281	225	180	161	129	112	90	64	45
Speed limit for T_{2B}	n_{2B}	rpm	230	190	170	160	135	95	85	65	50
Max. acceleration torque of motor	T_{Mmax}	Nm	88				44.2				
Max. acceleration current of motor	I_{maxdyn}	A_{eff}	100				50				
Static motor current	I_D	A_{eff}	38.6				21.9				
Moment of inertia (on motor shaft, without brake, with resolver)	J_1	$kgm^2 \cdot 10^{-4}$	117	117	116	115	115	60	60	60	60
Torsional backlash	j_t	arcmin	Standard ≤ 3 / Reduced ≤ 1								
Torsional rigidity	C_t	Nm/arcmin	585	580	570	560	560	520	525	480	395
Tilting rigidity	C_K	Nm/arcmin	1452								
Max. axial force	F_{Amax}	N	10050								
Max. tilting torque (distance from point of rotation to output flange 106.8 mm)	M_{Kmax}	Nm	3280								
Weight (with resolver, without brake)	m	kg	59.6				52.3				
Operating noise (measured at motor speed of 3000 rpm)	L_{PA}	dB(A)	≤ 72								
Max. permitted housing temperature		°C	+90								
Ambient temperature		°C	0 to +40								
Protection class			IP 65								
Mounting position			Any								
Lubrication			Synthetic oil, lubricated for life								
Insulating material class			F								
Paint			Metallic blue 250 and natural cast aluminum								

Tolerances T, I and n: Maximum +/- 10%.

¹⁾ greater than T_{2B} of the gearhead. In an emergency, can be used approx. 1000 times while the motor is rotating.

Please refer to the instructions and graphic illustration of the speed and torque values in the chapter "Information".

View A

View B

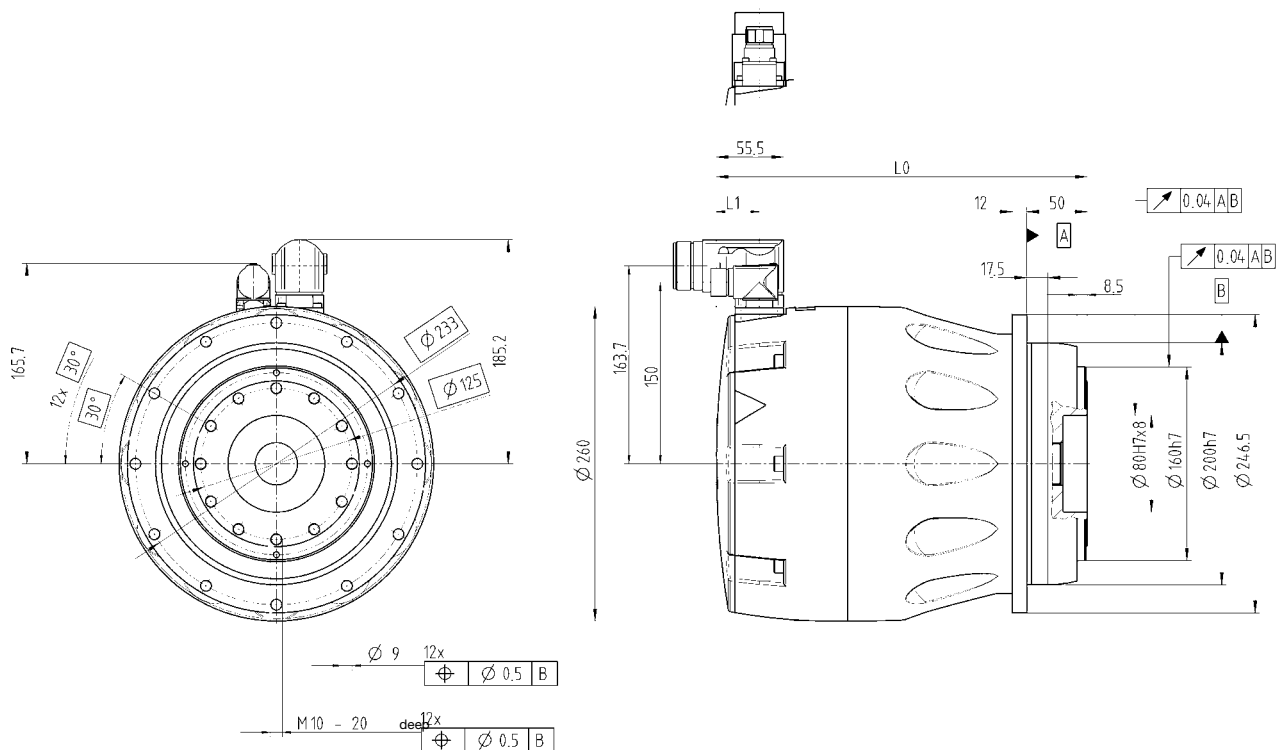

Electrical connection: Integral sockets, straight or angled, manufactured by Intercontec, SpeedTEC model, series A and B, size 1.5

without brake

Ratio	Motor feedback	Length L0 [mm]	Length L1 [mm]
i = 16, 20, 25, 28, 35	Resolver	337	36
	Hiperface	361	60
	EnDat	361	60
i = 40, 50, 70, 100	Resolver	307	36
	Hiperface	331	60
	EnDat	331	60

with brake

Ratio	Motor feedback	Length L0 [mm]	Length L1 [mm]
i = 16, 20, 25, 28, 35	Resolver	387	36
	Hiperface	411	60
	EnDat	411	60
i = 40, 50, 70, 100	Resolver	357	36
	Hiperface	381	60
	EnDat	381	60

Servo actuator TPM+ endurance

Work without limitations!

Water-cooled for continuous duty, this actuator merges dynamic performance with outstanding design.



Go the distance!

TPM+ endurance sets new standards for continuous applications, bringing to you cutting-edge motor technology for extreme power density, unparalleled dynamic control as well as optimized moment of inertia. This product is the marathon runner of the actuator world. The integrated water-cooling technology is part of this compact and powerful package, combining practical use with revolutionary design. The result for you: an actuator solution which keeps going and going to get you ahead.

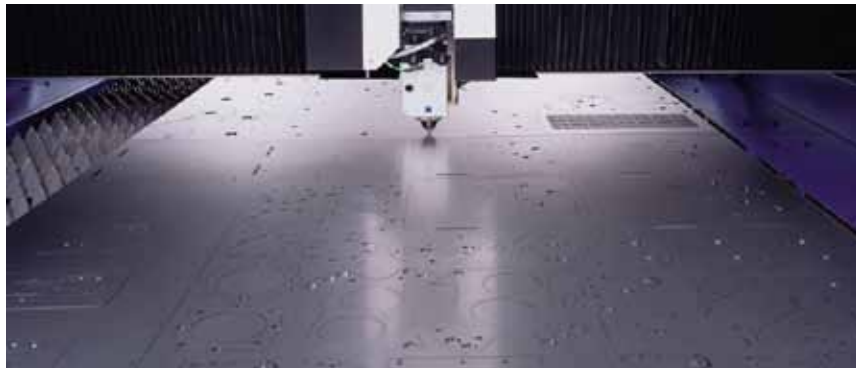

machine tools, laser machining

Foto: TRUMPF Gruppe

Applications

TPM+ endurance proves its strength particularly well in linear applications, i.e. with WITTENSTEIN's rack and pinion systems. The TPM+ endurance requires minimal idle time, if at all, and continues to guarantee high dynamics and stamina for your application.

Size TPM+ endurance



Length from Continuous power

010	203 mm	1.4 kW
050	308 mm	6.4 kW

More sizes on request

More dynamic ...

Bringing together cutting-edge motor technology, the highest power density, optimized moment of inertia and dynamic control with minimal backlash are achieved with this actuator. Including the drives, a weight advantage of up to 50% is possible.

Shorter ...

Optimal integration between motor and gearbox is designed in this very compact design solution. A length advantage of about 40% on comparable solutions is made possible by the coupling-free mounting and the optimized integration of components.

Cooler ...

A well designed liquid cooling system with outstanding efficiency leads to a product which is always ready to outperform.

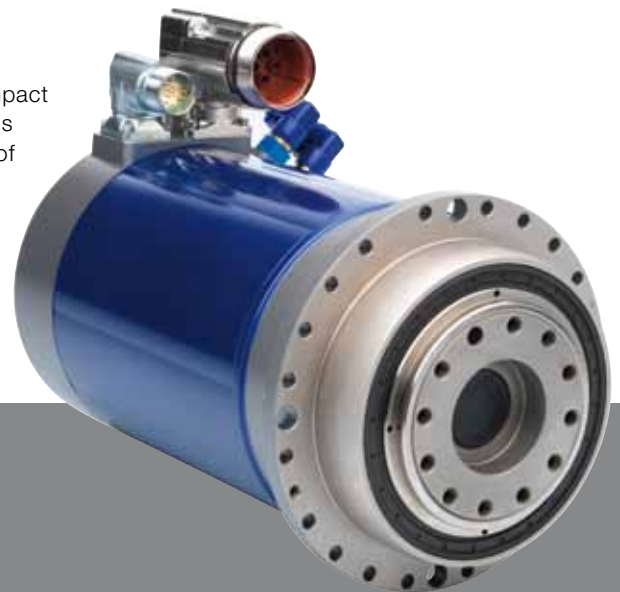

TPM+ endurance

TPM+ endurance

Size		010	050
Ratio	i	5	5
Intermediate circuit voltage	U_D V DC	560	560
Max. acceleration torque at output (max. 1000 cycles per hour)	T_{2B} Nm	52	216
Static output torque	T_{20} Nm	24	161
Max. speed	n_{2max} rpm	1200	1000
Speed limit for T_{2B}	n_{2B} rpm	580	400
Max. acceleration torque of motor	T_{Mmax} Nm	10,8	45
Max. acceleration current of motor	I_{maxdyn} A _{eff}	25	90
Static motor current	I_0 A _{eff}	11	58
Moment of inertia (on motor shaft)	J_2 kgm ² ·10 ⁻⁴	1.97	16.95
Torsional backlash	j_t arcmin	Standard ≤ 3 / Reduced ≤ 1	
Torsional rigidity	C_t Nm/arcmin	33	187
Tilting rigidity	C_K Nm/arcmin	255	560
Max. axial force	F_{Amax} N	2150	6130
Max. tilting torque	M_{Kmax} Nm	270	1335
Distance from point of rotation to output flange (For turning moment calculation)	z_2 mm	82.7	81.2
Weight	m kg	6.3	20.8
Operating noise (measured at motor speed of 3000 rpm)	L_{PA} dB(A)	≤ 59	≤ 65
Max. permitted housing temperature	°C	90	
Ambient temperature	°C	40	
Protection class		IP 65	
Mounting position		Any	
Lubrication		Synthetic oil, lubricated for life	
Insulating material class		F	
Paint		Metallic blue 250	

Tolerances T, I and n: Maximum +/- 10%.

Please refer to the instructions and graphic illustration of the speed and torque values in the chapter "Information".

Layout with incremental encoder / EnDat, without brake

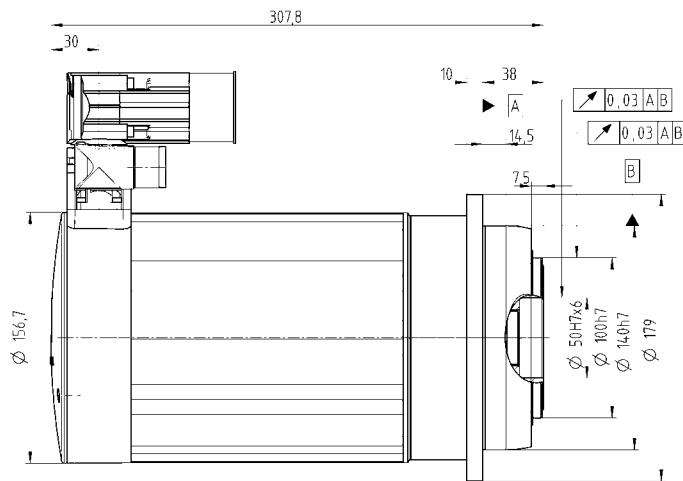
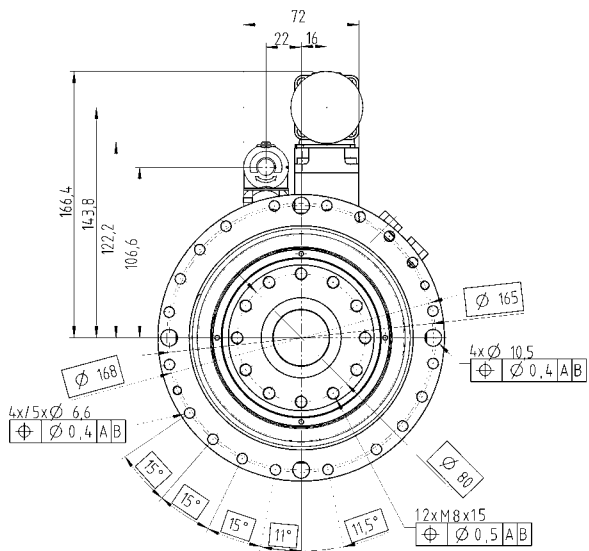
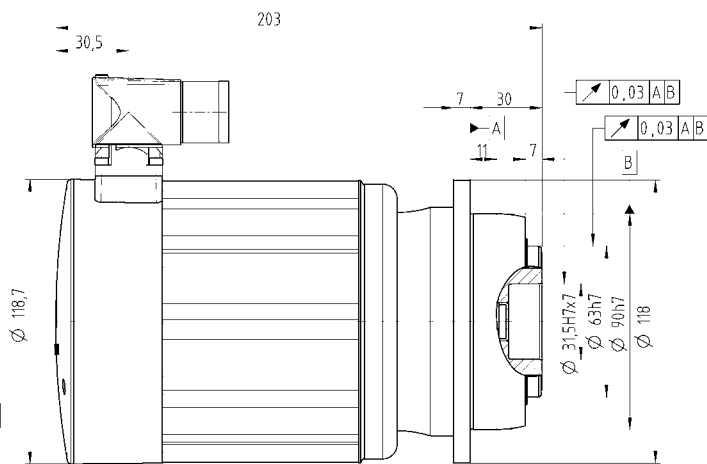
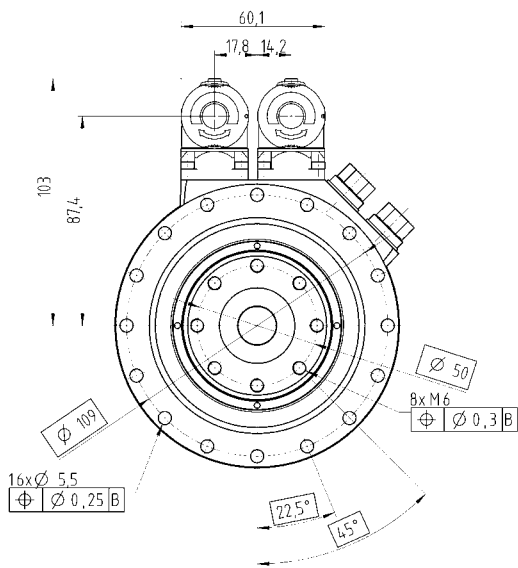

Other sizes and/or designs available upon request

Options for our **servo actuators**

Holding brake

A compact permanent magnet brake is fitted to secure the motor shaft when the actuator is disconnected from the power.

Characteristics include no torsional backlash, no residual torque when the brake is released, unlimited duty cycles at zero speed and a constant torque at high operating temperatures.

Size dynamic		004 and 010	025	050 and 110
Holding torque at 100°C	Nm	1.1	4.5	13
Power supply	V DC	24+6% / -10%		
Current	A	0.42	0.42	0.71

Size power		004	010	025	050	110
Holding torque at 100°C	Nm	1.1	4.5	13	23	72
Power supply	V DC	24+6% / -10%				
Current	A	0.42	0.42	0.51	1	1.2

Size high torque		10		25		50		110	
Ratios		22 - 110	154 - 220	22 - 55	66 - 220	22 - 55	66 - 220	22 - 88	110 - 220
Holding torque at 100°C	Nm	4.5	1.8	13	4.5	23	13	72	23
Power supply	V DC	24 +6%/-10%							
Current	A	0.42	0.42	0.71	0.42	1	0.71	1.2	1

Size endurance	On request

Where appropriate, the holding torque might be reduced at high ratios so as not to damage gearing.
For exact holding torques at the output, please refer to data tables of the actuators, such as TPM+ power 110 2-stage, page 38, line 5.

Temperature sensors

Different sensors are available to protect the motor coil from overheating.

Standard: PTC resistor, type STM160 according to DIN 44081/82
PTC resistor, type KTY 84-130

Encoder systems

A selection of encoder systems is available for positioning and speed measurement.

Standard: Resolver, 2-pin, 1 sin/cos cycle per rotation
Optional: Singleturn, EnDat 2.1 with 1V_{SS}, 512 S/R
Multiturn, EnDat 2.1 with 1V_{SS}, 512 S/R, 4096 R
Hiperface Singleturn, 128 S/R
Hiperface Multiturn, 128 S/R, 4096 R
TTL incremental encoder with hall signals and rectangular incremental signals 2048 S/R
Other resolver types available upon request

Cables

Pre-assembled cable harnesses for power and signals are available for selected servo controllers (see page 50). Available in 5, 10, 15, 20, 25, 30, 40 and 50 meters.

The cables are of the highest quality:

- Compatible with drag chains using highly flexible lines as specified in DIN VDE 0295, Cl. 6
- Oil and flame-resistant
- Free of halogen, silicone and CFCs

Adapter flange for TPM+ power

In certain installation situations, the flange bore holes must be accessed from the behind, for example. In such situations, an adapter flange with a large hole circle is available for the TPM+ power. The flange is already fitted to the actuator on delivery.

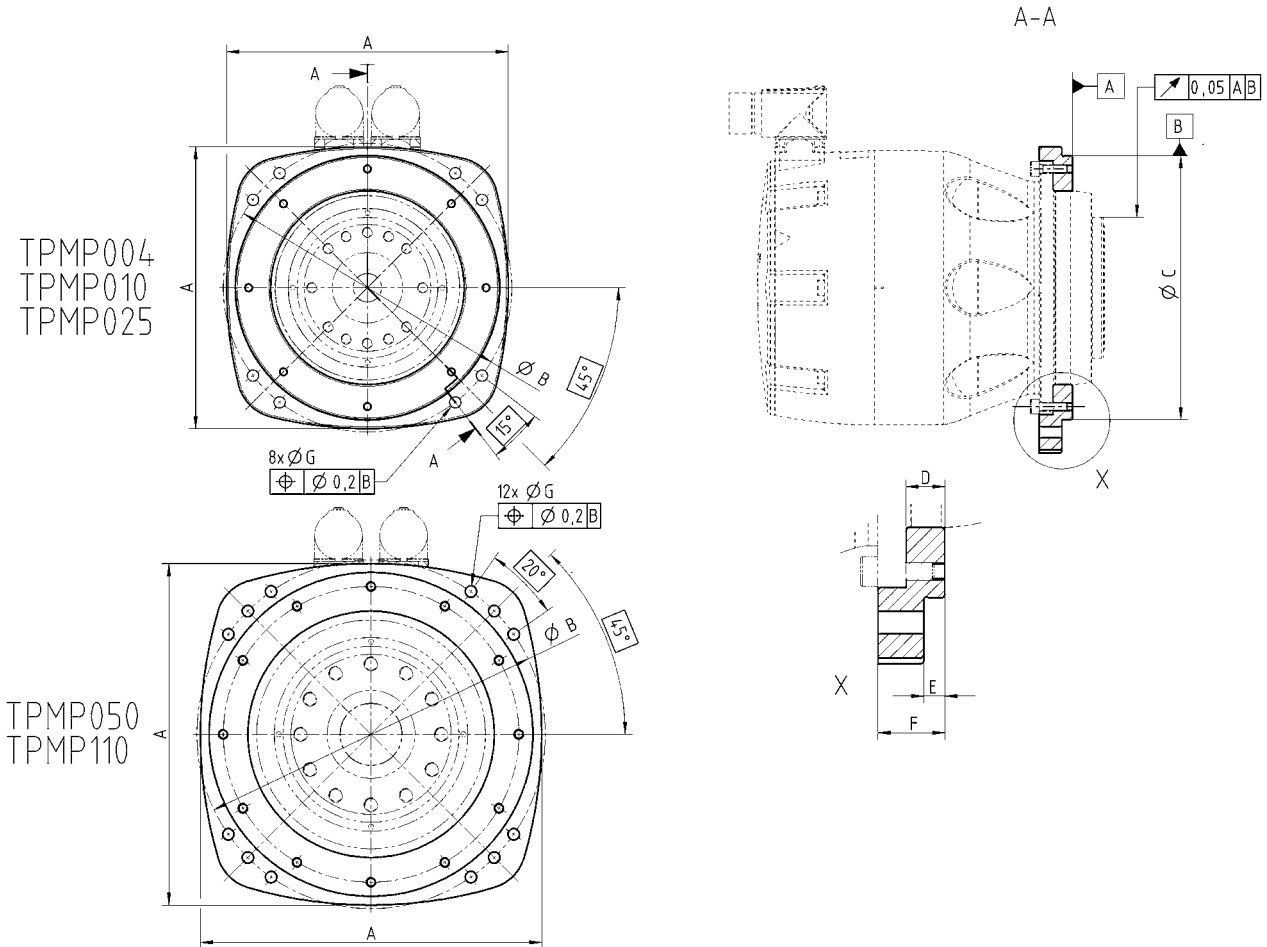

	TPM+ power 004	TPM+ power 010	TPM+ power 025	TPM+ power 050	TPM+ power 110
A	105	130	160	194	268
B	105	133	164	198	273
C	92 h7	120 h7	150 h7	184 h7	252 h7
D	8	10	11	14	16
E	5	5	6	7	8
F	12	17	19	24	28
G	4.5	5.5	5.5	6.5	9

Servo controllers

TPM+ actuators can be operated using a wide selection of different servo controllers. The table below contains a list of all servo controllers already tested with the TPM+ and provides information to assist in selecting the correct options. You can request a set of quick start instructions containing all the most important parameters for configuring the servo controller. When selecting the servo controller, please take account of the actuator's current consumption.

Manufacturer	Version/Type	Motor feedback				Temperature sensor		DC bus voltage	
		Resolver	EnDat	Hiperface	TTL-Geber	PTC	KTY	320V DC	560V DC
Bosch Rexroth	IndraDrive	x	x	x	-	x	x	x	x
Beckhoff	AX5000	x	x	x	-	x	x	x	x
B & R	AcoPos	x	x	-	-	x	x	-	x
Control Techniques	UniDrive SP	x	x	x	x	x	-	-	x
Kollmorgen	Servostar 300	x	x	x	-	x	-	x	x
	Servostar 400	x	x	x	-	x	-	x	x
	Servostar 700	x	x	x	-	x	-	x	x
	AKD	x	x	x	-	x	-	x	x
ESR Pollmeier	TrioDrive D/xS	x	x	x	-	x	x	x	-
	MidiDrive D/xS	x	x	x	-	x	x	-	x
ELAU	PacDrive MC-4	-	-	x	-	x	-	x	x
Parker	Compax 3	x	-	x	x	x	-	x	x
KEB	Combivert F5-Servo	x	x	x	-	x	-	x	x
	Combivert F5-A Servo	x	-	-	-	x	-	x	x
Lenze	Global Drive 93xxx	x	-	x	-	x	x	-	x
	Global Drive 94xx	x	-	x	-	x	x	x	x
	ECS Servosystem	x	-	x	-	x	x	x	x
NUM	MDLU 3	-	-	x	-	x	-	-	x
Rockwell ¹⁾	Kinetix 6000	-	-	x	-	x	-	x	x
	Ultra 3000	-	-	x	-	x	-	x	x
Siemens	SimoDrive 611U	x	x	-	-	-	x	-	x
	SimoDrive 611D	-	x	-	-	-	x	-	x
	Masterdrive MC	x	x	-	-	x	x	-	x
	Sinamics S120	x	x	-	-	-	x	-	x

¹⁾ TPM+ dynamic only: Order with encoder option E or V and pin assignment 5

Pin assignment 1

Version with resolver, size 1

Integral power socket: SpeedTEC BED size 1, Intercontec 6-pin, pin contact ø2mm

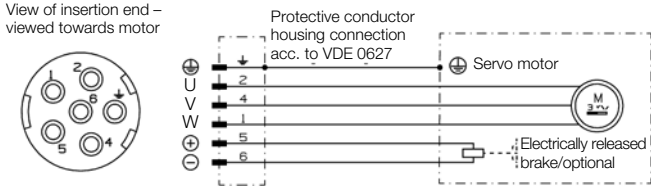

Version with optical sensor, size 1

Power connector: SpeedTEC BED size 1, Intercontec 6-pin, pin contact ø2mm

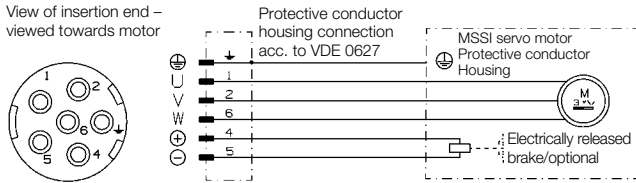

Version with resolver or optical sensor, size 1.5

Integral power socket: SpeedTEC CED size 1,5, Intercontec 6-pin, pin contact 4 x ø3.6 mm and 2 x ø2 mm

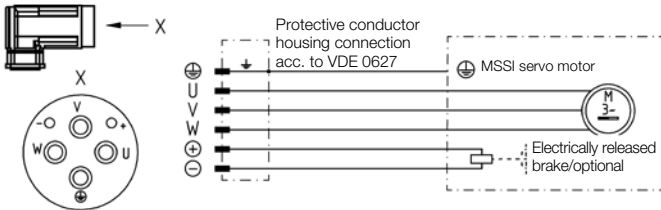

Options "S" and "M"

Integral signal socket: SpeedTEC AED size 1, Intercontec 17-pin, E-part, pin contact ø1mm, housing code 0°

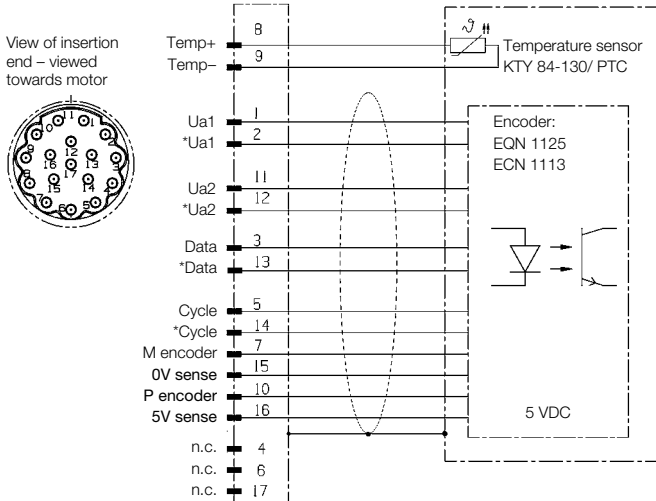

Option "R"

Integral signal socket: SpeedTEC AED size 1, Intercontec 12-pin, P-part, pin contact ø1mm, housing code 0°

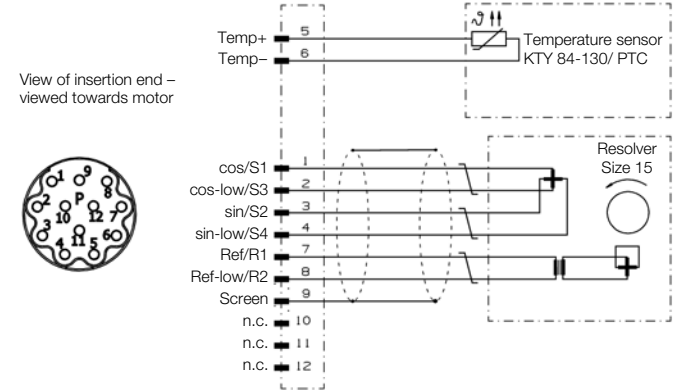

Options "N" and "K"

Signal connector: SpeedTEC AED size 1, Intercontec 12-pin, P-part, pin contact ø1mm, housing code 0°

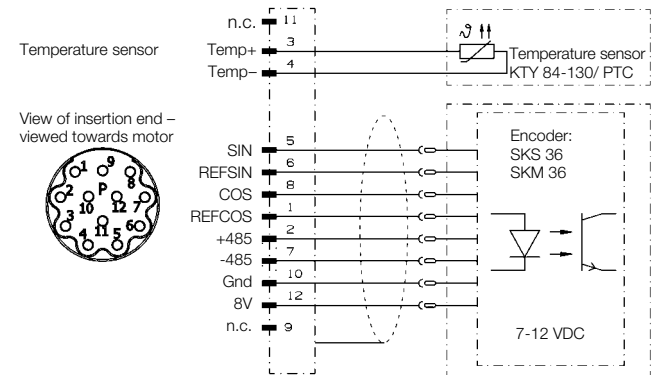

Option "T"

Integral signal socket: SpeedTEC AED size 1, Intercontec 17-pin, E-part, pin contact ø1mm, housing code 0°

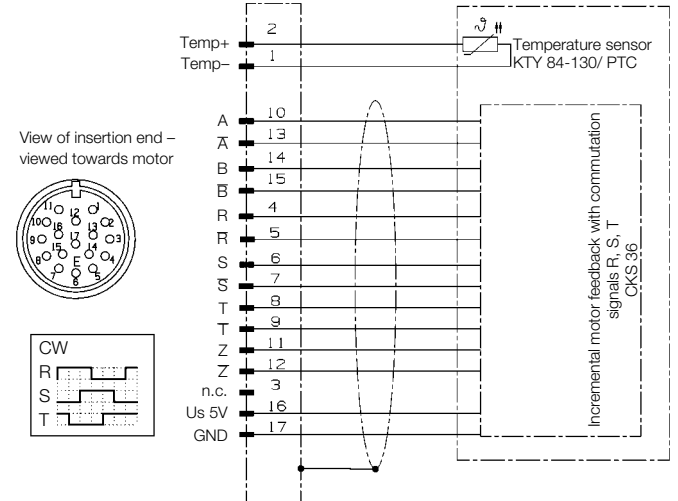

Pin assignment 4

Version with resolver and optical sensor, size 1

Integral power socket: SpeedTEC BED size 1, Intercontec 9-pin, pin contact 4x ø2mm + 5 x ø1mm

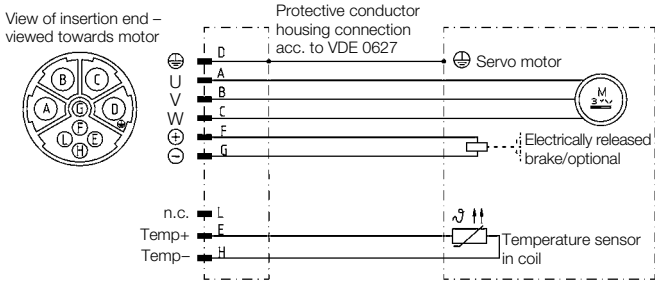

Option "R"

Integral signal socket: SpeedTEC AED size 1, Intercontec 12-pin, P-part, pin contact ø1mm, housing code 0°

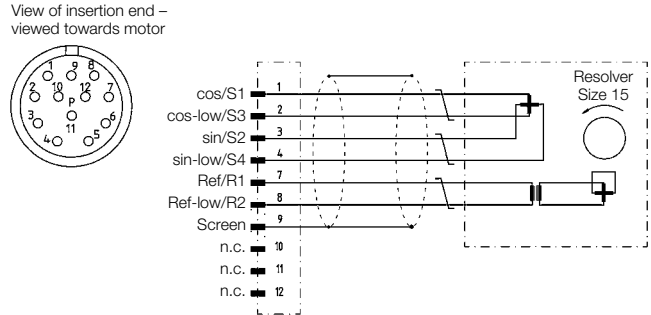

Version with resolver and optical sensor, size 1.5

Integral power socket: SpeedTEC CED size 1.5, Intercontec 8-pin, pin contact 4x ø3.6mm + 4 x ø2mm

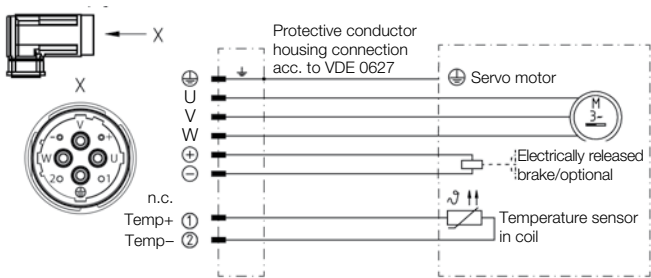

Options "N" and "K"

Signal connector: SpeedTEC AED size 1, Intercontec 12-pin, P-part, pin contact ø1mm, housing code 0°

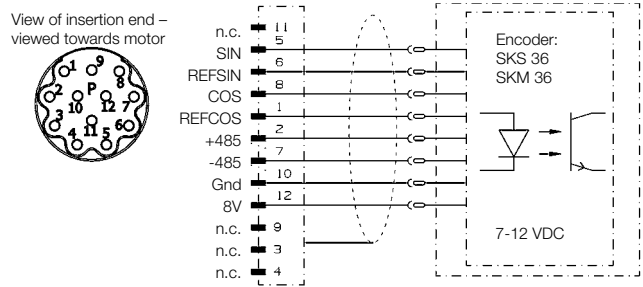

Options "S" and "M"

Signal connector: SpeedTEC AED size 1, Intercontec 17-pin, E-part, pin contact ø1mm, housing code 0°

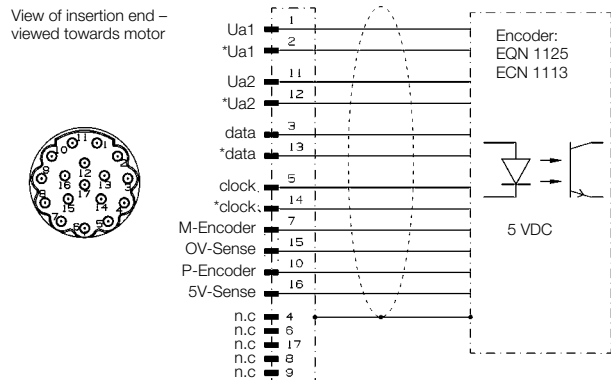

Pin assignment 5 only for TPM+ dynamic (Rockwell-compatible)

Version with optical sensor

Integral power socket: SpeedTEC BED size 1, Intercontec 9-pin, pin contact 4x ø2mm + 5 x ø1mm

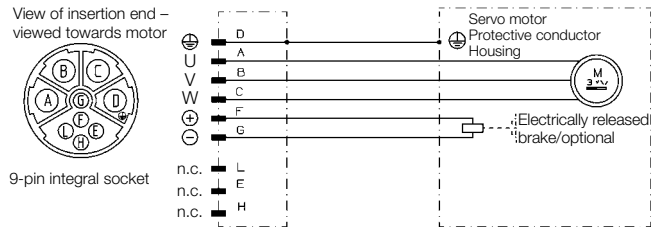

Options “E” and “V”

Integral signal socket: SpeedTEC AED size 1, Intercontec 17-pin, E-part, pin contact ø1mm, housing code 0°

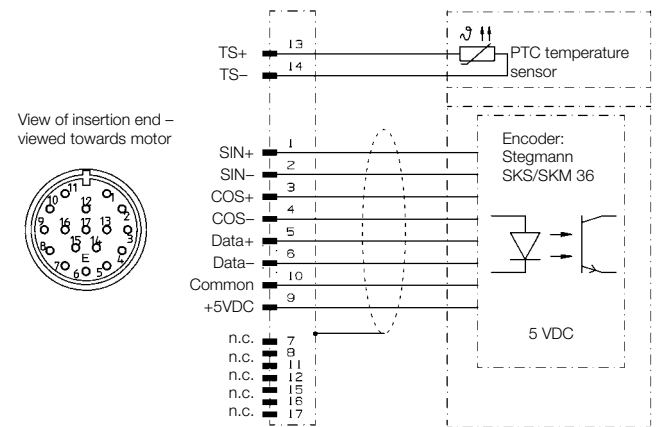

On TPM+ dynamic sizes 004, 010 and 025 with 320V intermediate circuit voltage.

Options “E” and “V”

Integral signal socket: SpeedTEC AED size 1, Intercontec 17-pin, E-part, pin contact ø1mm, housing code 0°

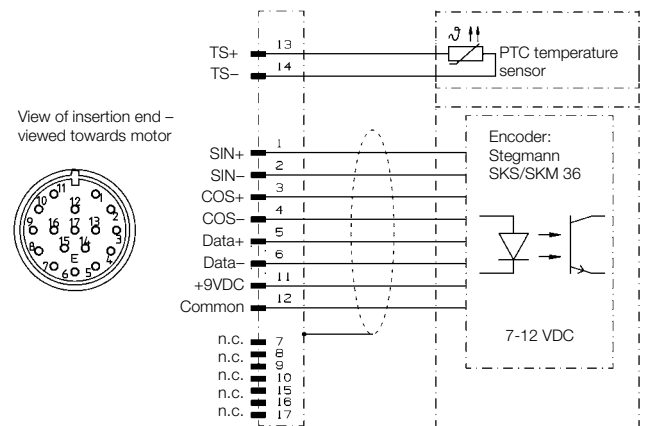

On TPM+ dynamic with 560V intermediate circuit voltage.

TPM+ order codes

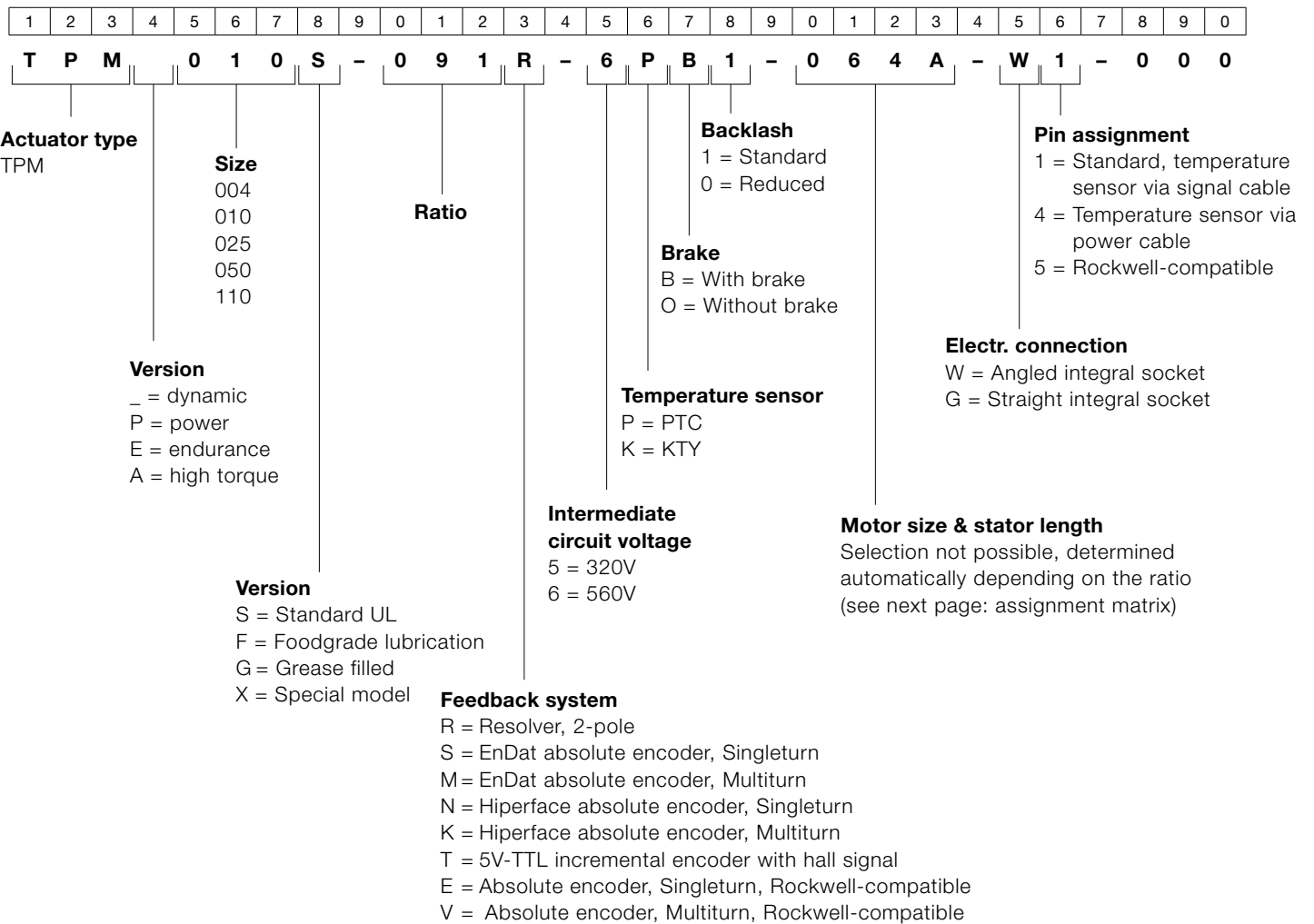

Assignment matrix

Ratio	BG 004		BG 010				BG 025			BG 050				BG 110		
	dynamic	power	dynamic	power	high torque	endurance	dynamic	power	high torque	dynamic	power	high torque	endurance	dynamic	power	high torque
4	x	64B	x	94C	x	x	x	130D	x	x	155D	x	x	x	220D	x
5	x	64B	x	94C	x	94B	x	130D	x	x	155D	x	130F	x	220D	x
7	x	64B	x	94C	x	x	x	130D	x	x	155D	x	x	x	220D	x
10	x	64B	x	94C	x	x	x	130D	x	x	155D	x	x	x	220D	x
16	53B	64B	64B	94C	x	x	94C	130D	x	130D	155D	x	x	130E	220D	x
20	x	64B	x	94C	x	x	x	130D	x	x	155D	x	x	x	220D	x
21	53B	x	64B	x	x	x	94C	x	x	130D	x	x	x	130E	x	x
22	x	x	x	x	94C	x	x	x	130D	x	x	155D	x	x	x	220H
25	x	64B	x	94C	x	x	x	130D	x	x	155D	x	x	x	220D	x
27,5	x	x	x	x	94C	x	x	x	130D	x	x	155D	x	x	x	220H
28	x	64B	x	94C	x	x	x	130D	x	x	155D	x	x	x	220D	x
31	53B	x	64B	x	x	x	94C	x	x	130D	x	x	x	130E	x	x
35	x	64B	x	94C	x	x	x	130D	x	x	155D	x	x	x	220D	x
38,5	x	x	x	x	94C	x	x	x	130D	x	x	155D	x	x	x	220H
40	x	64A	x	94A	x	x	x	130A	x	x	155A	x	x	x	220B	x
50	x	64A	x	94A	x	x	x	130A	x	x	155A	x	x	x	220B	x
55	x	x	x	x	94C	x	x	x	130D	x	x	155D	x	x	x	220H
61	53A	x	64A	x	x	x	94A	x	x	130A	x	x	x	130D	x	x
64	53A	x	64A	x	x	x	94A	x	x	130A	x	x	x	130D	x	x
66	x	x	x	x	x	x	x	x	94C	x	x	130D	x	x	x	220D
70	x	64A	x	94A	x	x	x	130A	x	x	155A	x	x	x	220B	x
88	x	x	x	x	94C	x	x	x	94C	x	x	130D	x	x	x	220D
91	53A	x	64A	x	x	x	94A	x	x	130A	x	x	x	130D	x	x
100	x	64A	x	94A	x	x	x	130A	x	x	155A	x	x	x	220B	x
110	x	x	x	x	94C	x	x	x	94C	x	x	130D	x	x	x	155D
154	x	x	x	x	94A	x	x	x	94C	x	x	130D	x	x	x	155D
220	x	x	x	x	94A	x	x	x	94C	x	x	130D	x	x	x	155D

TPM+ power cable order codes

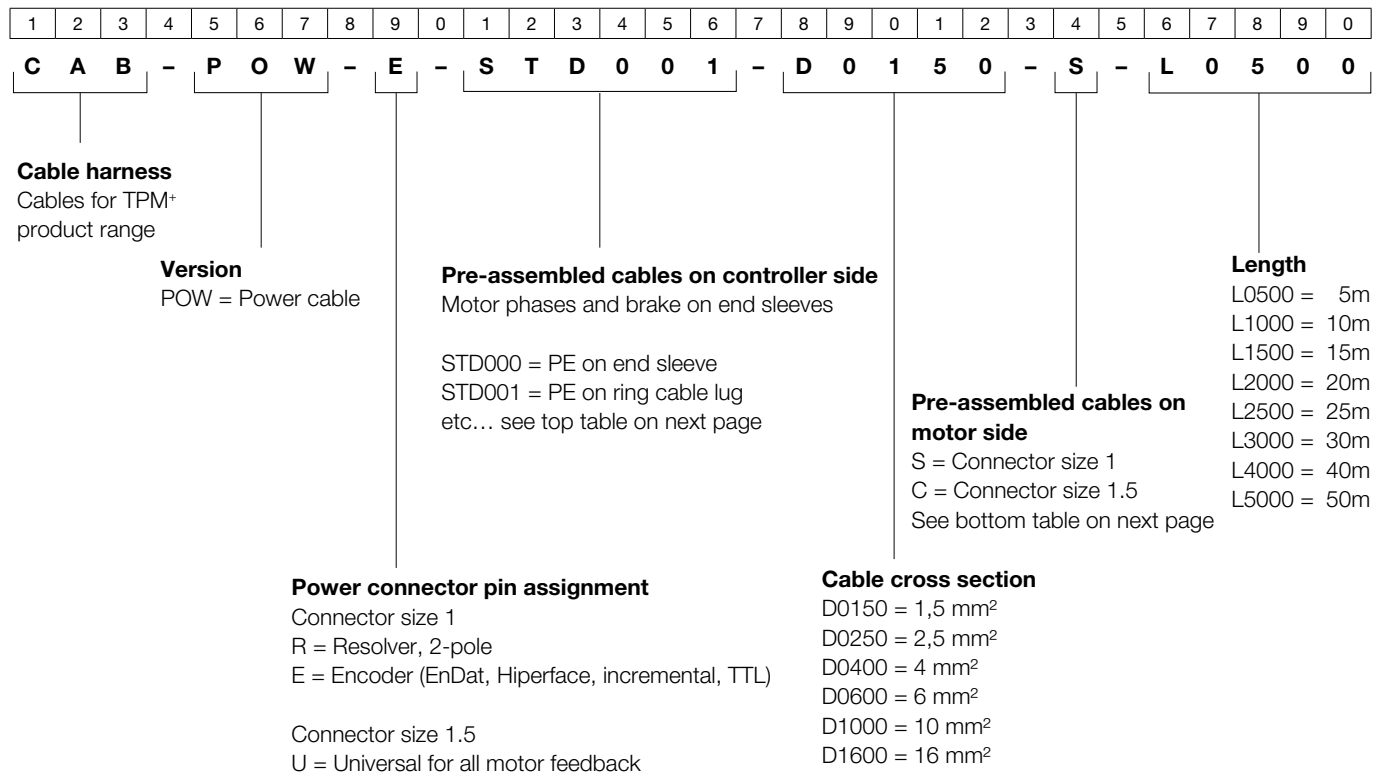

TPM+ signal cable order codes

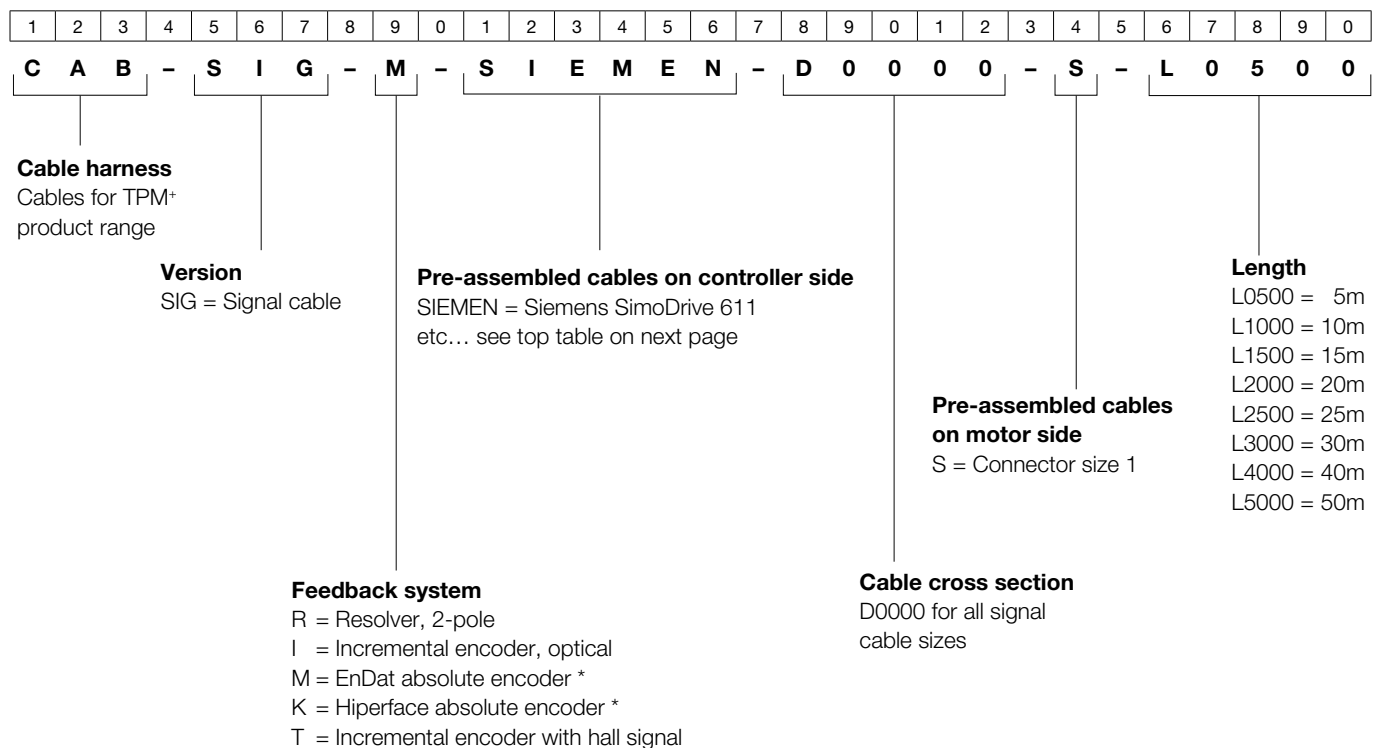

* The Multiturn and Singleturn cables are identical

Pre-assembled cables on controller side

Cable for pin assignment 1 (temperature sensor in signal cable)

Manufacturer	Controller	Pre-assembled signal cable	Pre-assembled power cable
B&R	Acopos	BURACO	STD000
ELAU	PacDrive MC4	ELAMC4	ELAMC4
Bosch Rexroth	IndraDrive	BRCIND	STD000
Control Techniques	UniDrive SP	CT_SP_	STD001
Siemens	Sinamics S120	SIEMEN	STD001
	SimoDrive 611	SIEMEN	STD001
	MasterDrive MC	SIEMEN	STD001

Cable for pin assignment 4 (temperature sensor in power cable)

Manufacturer	Controller	Pre-assembled signal cable	Pre-assembled power cable
ELAU	PacDrive MC4	ELAUP4	ELAUP4
Bosch Rexroth	IndraDrive	BRC_I4	STD_P4

Other cable versions available upon request

Pre-assembled cables on motor side and cable cross sections

Stator	Cable cross section mm ²	Power connector
053A	1.5	Size 1 M23
053B	1.5	Size 1 M23
064A	1.5	Size 1 M23
064B	1.5	Size 1 M23
094A	1.5	Size 1 M23
094C	1.5	Size 1 M23
130A	1.5	Size 1 M23
130D	2.5	Size 1 M23
130E	2.5	Size 1 M23
155A	1.5	Size 1 M23
155D	2.5	Size 1 M23
220B	4	Size 1.5 M40
220D	10	Size 1.5 M40
220H	16	Size 1.5 M40

Recommended cable cross sections according to EN 60204-1, ambient temperature 40°C, type of installation C

Selection of the cross section according to the motor size and stator length.

Information

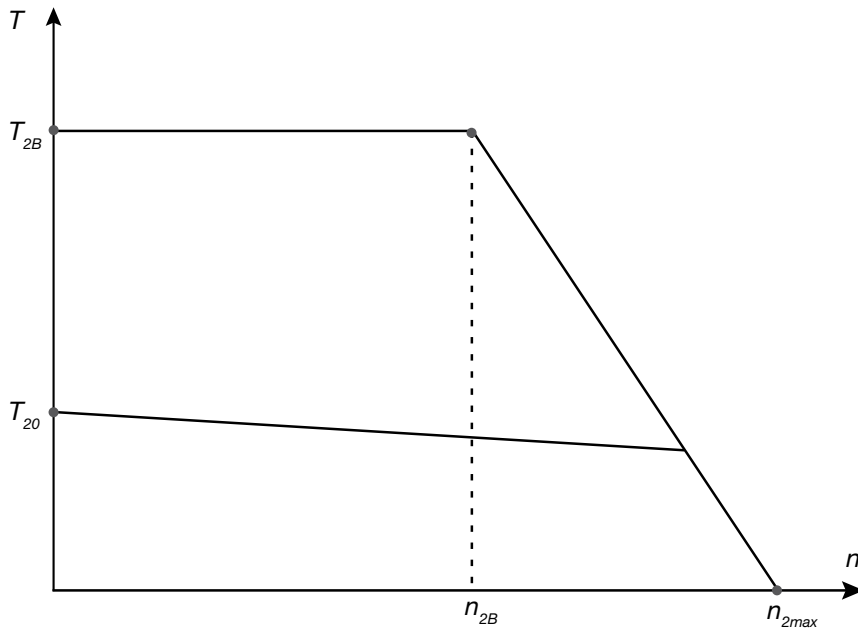

Symbol	Designation	Unit
T_{2dyn}	Dynamic load torque	Nm
T_{2Pr}	Process load torque	Nm
T_{2b}	Total load torque at gearhead output	Nm
T_{1b}	Total load torque at motor	Nm
T_{Mmax}	Maximum acceleration torque of motor	Nm
T_{2B}	Maximum permissible acceleration torque at gearhead output	Nm
T_{20}	Permanent static torque at gearhead output	Nm
M_{2k}	Tilting torque at gearhead output	Nm
$M_{2k max}$	Maximum permissible tilting torque at gearhead output	Nm
J_L	Mass moment of inertia of external load	kgm ²
J_1	Mass moment of inertia of drive (motor side)	kgm ²
i	Gearhead ratio	–
η	Gearhead efficiency (1stage 0.97 / 2-stage 0.94)	–
α	Acceleration of external load	rad/s ²
n_{2B}	Speed limit* for T_{2B}	rpm
n_{2max}	Maximum permitted output speed	rpm

* The maximum acceleration torque available at the gearhead output decreases if speed limit n_{2B} is exceeded.

Information

To fully utilize gearhead actuators from the TPM+ family, please check the maximum permissible acceleration torques with reference to the following points:

Calculate the maximum acceleration torque required at the gearhead output:

$$T_{2dyn} = \alpha * J_L$$

Identify additional process loads and calculate the total load torque at the gearhead output:

$$T_{2b} = T_{2dyn} + T_{2Pr}$$

Then calculate the total load torque required at the motor:

$$T_{1b} = (\alpha * J_L + T_{2Pr}) * \frac{1}{\eta * i} + \alpha * i * J_1$$

To fully utilize the gearhead actuator during acceleration, the following conditions must be guaranteed:

Condition for the total load torque at the gearhead output:

$$T_{2b} \leq T_{2B}$$

Condition for the total load torque at the motor:

$$T_{1b} \leq T_{Mmax}$$

In addition, the tilting torque produced from prevalent radial and axial forces must be determined and compared with the permissible value:

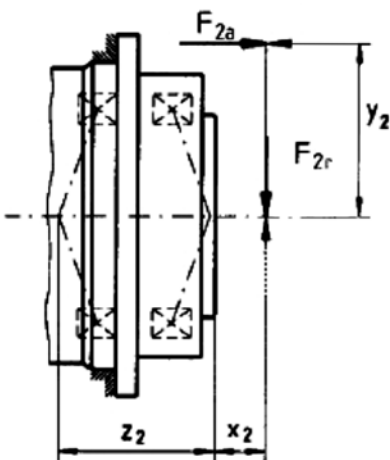

$$M_{2k} = \frac{F_{2a} * y_2 + F_{2r} * (x_2 + z_2)}{1000}$$

$$M_{2k} \leq M_{2K max}$$

Information

Please refer to the table below for values corresponding to z_2 :

TPM+ dynamic	004	010	025	050	110
Z_2 [mm]	57.6	82.7	94.5	81.2	106.8

TPM+ high torque		010	025	050	110
Z_2 [mm]		82.7	94.5	81.2	106.8

TPM+ power	004	010	025	050	110
Z_2 [mm]	57.6	82.7	94.5	81.2	106.8

TPM+ endurance		010		050	
Z_2 [mm]		82.7		81.2	

If you require a more complex design, in particular the thermal characteristics of our drives, we recommend analyzing the drive train using our design software cymex®.

Do you still have questions?

Do you have any special questions about our products and services?
Visit our homepage www.wittenstein-us.com for further information.



WITTENSTEIN motion control GmbH · Walter-Wittenstein-Straße 1 · 97999 Igersheim · Germany · Tel. +49 7931 493-0

www.wittenstein-motion-control.de