

Main characteristics

Miniaturised Ø38 encoder series. Used when a minimal size is required even providing excellent performances.

- Resolution up to 2.000 ppr with zero.
- Several electronic output configurations available.
- Up to 28 Vdc input voltage.
- Up to 100 kHz frequency response
- Several flanges available
- Up to 3.000 rpm speed rotation
- Up to IP54 sealing



Ordering code

Full stop to separate special versions.

EL 38 F 500 Z 5/28 N 6 X 3 P R . XXX

Incremental encoder series **EL**

Body dimension **38**

Type of flanges

mod.EL 38 F **F**
mod.EL 38 G **G**

Resolutions

PPR: from **1** to **2000**

Please, directly contact our offices for pulses availability

Zero pulse

without zero pulse **S**
with zero pulse **Z**

Input voltage

Input voltage **5 ÷ 28**

LINE DRIVER available only with input voltage 5 Vdc: 8 - 24 Vdc

R radial

P cable output (standard length 0.5 m)

R.P.M.

3 3000 max

Enclosure rating

X standard IP54

Bore diameter

6 ø 6 g6 mm
8 ø 8 g6 mm
9 ø 9,52 g6 mm (3/8")
10 ø 10 g6 mm

Output types

N NPN
C NPN OPEN COLLECTOR
P PUSH PULL
L LINE DRIVER

For optionals about output types please refer to incremental outputs section

Special version code numbered from 001 to 999

EL 38 F

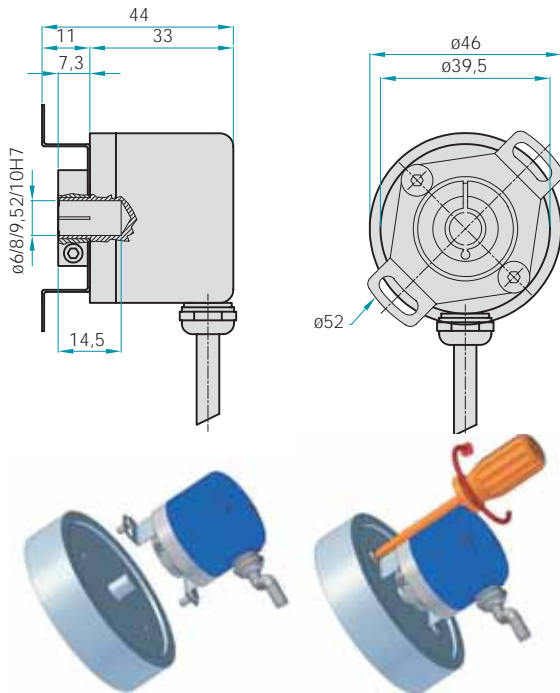

HOW TO MOUNT IT

- 1) Couple the encoder shaft with the motor shaft
- 2) Fix the spring at the motor flanges without screwing it
- 3) Fix the encoder shaft by the metal ring
- 4) Block the spring

EL 38 G

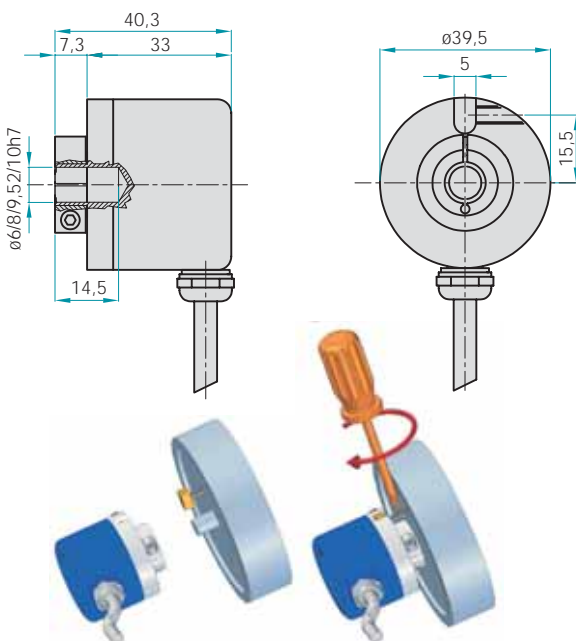

HOW TO MOUNT IT

- 1) Mount the antirotation pin on the motor flange.
- 2) Couple the encoder shaft with the motor shaft, ensuring that the pin is inserted on the cave on the frontal part of the encoder (maintaining a minimum distance of 0,5 mm)
- 3) Fix the encoder shaft by the metal ring

Electrical specifications

Resolution	from 1 to 2000 PPR
Input voltage	5 ÷ 28 Vdc LINE DRIVER available only with input voltage 5 / 8=24 Vdc
Input current with no output load	80 mA MAX
Source and sink current	50 mA for channel 20 mA for channel with LINE DRIVER
Output types	NPN / NPN OPEN COLLECTOR / PUSH PULL / LINE DRIVER
Output frequency	100 KHz Max
Frequency response	$F = \frac{\text{RPM} \times \text{Resolution}}{60}$

Mechanical specifications

Bore diameter	ø6-ø8-ø9.52 (3/8")-ø10 mm
Enclosure rating	IP54 standard
Shaft speed	3000 RPM
Max shaft load	5N (0.5 Kp) axial 5N (0.5 Kp) radial
Shock	50 G for 11 msec
Vibrations	10G 10 ÷ 2000 Hz
Bearings life	10 ⁹ revolutions
Bearings	n° 2 ball bearings
Shaft material	Stainless steel AISI303
Body material	Aluminium D11S - UNI 9002/5
Housing material	Fe
Operating temperature	0° ÷ +60°C
Storage temperature	-25° ÷ +70°C
Weight	150 g