



ICO INTERFACE GENERAL DESCRIPTION

Introduction

Absolute encoders with an incremental output code combine the advantages of absolute encoders with those of incremental ones, in a single product. These are to all effects, absolute encoders because they measure the absolute position inside the turn and not the incremental position with respect to the zero notch, however, the output signals are those of incremental encoders. The advantages are considerable because compared to classic absolute encoders, the number of wires for the wiring is considerably reduced (above all when the bits start to be numerous). Also, for position reading, a simple counter is sufficient for the incremental encoder, instead of boards or multi I/O instruments.

Description

Concerning the reading system, an absolute encoder with an incremental output is exactly the same as for a standard absolute encoder, in other words, a beam of light, captured by photo-receivers and interrupted by a rotating disc with transparent and opaque zones. The disc however, is special in that apart from having the tracks for the absolute code bits, it also has electrical tracks of the incremental type, staggered at 90° and in phase with the absolute code.

The following figure shows the encoder block diagram:

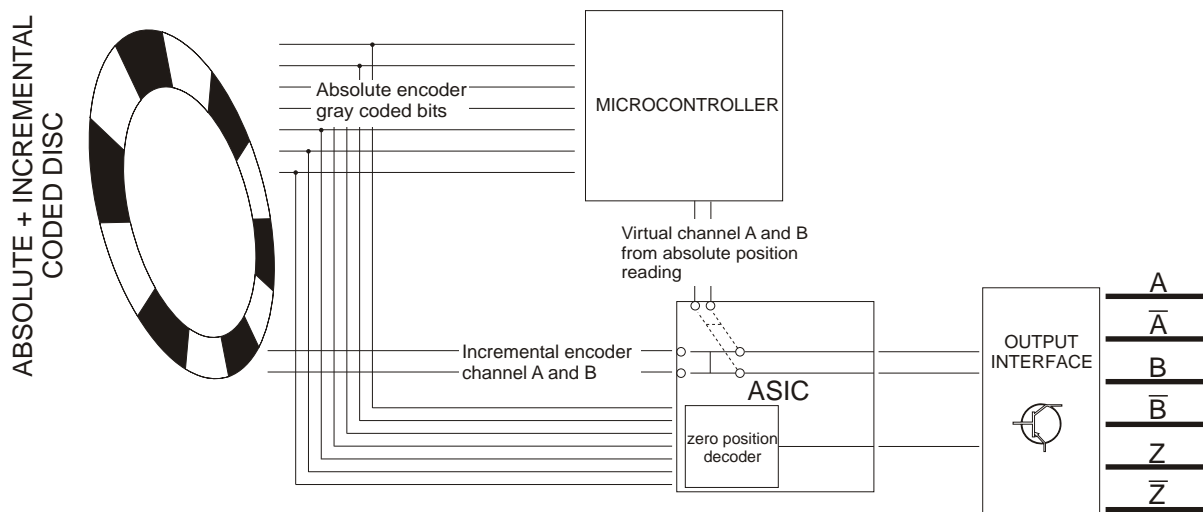

A micro-controller is distinguished that manages the encoder operation and the initialisation sequences; it reads the absolute position and controls the ASIC device. This latter implements a switch for channels A and B and a position decoder for generating the Z channel. Finally, the output interface converts the signals from the ASIC into the electronic output levels.

Operating principle

When the encoder is powered up, it goes into a stand-by state, in which the A, B and Z channels are at a low logical level and the READY output is disabled: in this state, the encoder does not work and any shaft rotation does not produce effects on the output channel status.

To make the encoder operate, it is necessary to activate the RESTART input for at least 50 ms.. In this way, the micro-controller managing the encoder reads the absolute position and send a number of impulses equal to the absolute position detected, in output to channels A and B. The impulse "train" in question is preceded by an impulse on channel Z, permitting the possible zeroing of the counter.

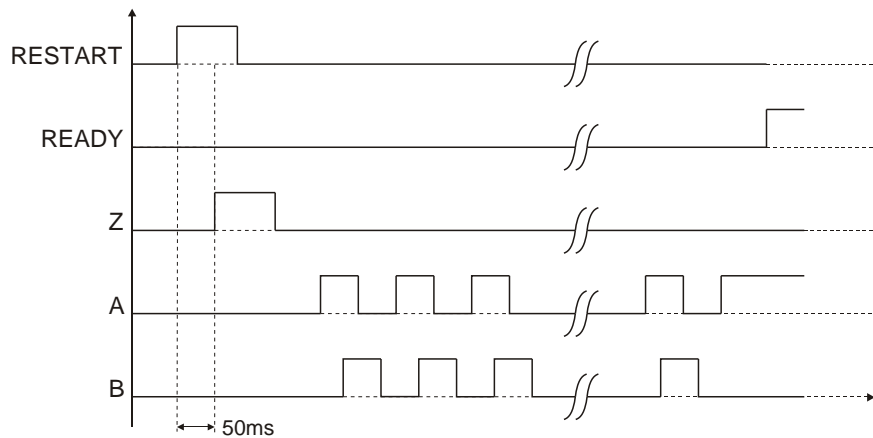

After this impulse train has been sent, the READY output assumes the high logical level and the counter count will be equal to the position of the absolute encoder. At this point, the micro-controller releases control of output channels A, B, and Z and the part that manages the incremental encoder starts to function.

This series of operations is defined as the "START-UP" sequence, at the end of which, the encoder becomes effectively operational.

U/D

The U/D (Up-Down) input, permits inversion of the rotation direction permitting the encoder count to increased/decreased. In particular, by connecting this input to the power supply positive, we increase the count with the clockwise rotation of the shaft (seen from the front), vice versa, by connecting to the negative, (or by leaving it disconnected), we obtain an increase with ant-clockwise shaft rotation.

Restart

When the RESTART input is activated for at least 50 ms., this permits the encoder to execute the START-UP sequence. This sequence can be automatically executed at the moment the power supply is switched on, by permanently connecting the RESTART input to the power supply positive.

Ready

The READY output indicates the encoder operational status. When found at a low logical state, this means that the encoder is not functioning and that it is necessary to activate the RESTART input. At the end of the "START-UP" procedure, it goes to a high logical level, indicating that the encoder is ready to operate. The READY output also indicates any encoder malfunctioning due for example, to power supply voltage interruptions or to internal faults to the extent that if continuously monitored, it can be used as an authentic alarm.

Pursuit

If the encoder is moving due to a drive offset or vibrations during the "START-UP" procedure, the position read at the start of the procedure itself, may not be the same as the one read at the end causing an error between the real position and the one effectively sent in the form of incremental impulses. The encoder check this by reading the absolute position value also after sending the incremental impulse sequence; if there are any differences, it continues to send impulses until the absolute position read is the same as the one sent in the form of incremental impulses. Only at this moment is the "START-UP" procedure terminated and the READY output is activated. If the rotation speed is faster than that at which the encoder performs acquisition and the sending of the absolute position, the READY output remains disabled.

Resolution levels

Absolute encoders with incremental output code are available with various levels of resolution, up to a maximum of 1024 imp/turn. The number of impulses specified, refers to the incremental ones; in this way, a 1000 imp/turn encoder has a resolution level equal to a 4000 pos./turn absolute encoder. This resolution is obtained by setting a x 4 multiplication factor in the encoder reading device.

Output electronics

The output electronics available are Push-Pull and Line Driver; the READY output is the push-pull type.

