



OEM750series microstepping drives

*Catalogue 1602.002.01
February, 1998*



Improved performance based on a winning formula

Developed from the highly-successful OEM350/650 series, the OEM750 and OEM750X combine even higher performance with the benefits of high-resolution microstepping and a space-saving package. The electronic damping circuitry used in the acclaimed ZETA drive has been adapted for use within this new compact module. The result is a dramatic reduction in midrange instability, reducing the safety margin required and thereby increasing the usable torque.

OEM750 models have been designed to accommodate a very wide range of motors and supply voltages. With this in mind, a current loop gain adjustment feature has been incorporated. This means that only one version of the drive module is required to cover the full range of motor inductances from 0.2mH to 80mH at all supply voltages between 24 and 75V. Output current is programmable between 150mA and 7.5A. The single-voltage DC power input may be derived from an OEM300 module.

Both the OEM750 and OEM750X offer a choice of motor resolutions up to 50,800 steps/rev to provide very smooth rotation over the entire speed range. The output to the motor is extensively protected against short circuits, over and under voltage and overtemperature. Programmable automatic current reduction at standby is incorporated.

OEM750X microstep drive with built-in RS232C indexer

Combining the OEM750 microstep drive with an economic RS232C controller, this version uses Parker's X-Code command language for straightforward, user-friendly programming. With a good range of basic control functions, this package offers an attractive solution in many low to medium power applications. The built-in controller may be equipped with 2K bytes of battery-backed RAM which will store up to 7 complete motion sequences, allowing it to be pre-programmed for specific functions selected via the configurable inputs.

Up to 256 drives may be daisy chained on one RS232 serial port. Configurable inputs are used for remote sequence select, trigger, limit switch and address select functions. In addition there are two programmable outputs for the control of auxiliary machine functions.

OEM750 and 750X common features

Performance

- Designed for use with any motor inductance between 0.2mH and 80mH
- Selectable output current from 0.15A to 7.5A peak
- Three-state current control for cooler operation
- Selectable resolution up to 50,800 steps/rev
- Auto standby reduces motor current at rest
- Single 24-75 VDC power supply input
- Compatible with a wide range of motors
- Six current profiles to optimise smoothness
- Anti-resonance feature controls midrange instability



Protection circuits

- Short circuit (phase-to-phase and phase-to-ground) and overtemperature protected
- Power dump circuitry to protect drive from excessive regenerated energy during deceleration
- Self-test feature to verify correct system operation

Physical

- Status/fault LED indicators
- Application specific integrated circuit (ASIC) and surface mount technology minimise product footprint and overall package size, improve product reliability
- Optically isolated fault output
- Heat plate design allows thermal dissipation via the mounting surface or a suitable heatsink
- Larger right-angle screw terminal allows side-to-side mounting or Eurorack compatibility
- Configuration by DIP switches
- CE marked with LVD compliance, UL recognised
- Overall dimensions 127 x 91 x 41 mm

OEM750X indexer/drive

- Standard RS-232C serial communications interface
- Straightforward Parker X Language
- Optional 2K bytes of battery-backed RAM to store up to 7 motion programs (-M2 option)
- Address selectable for daisy chaining up to 8 units by hardware, or up to 256 units by software
- Incremental encoder support for position tracking, stall detection and position maintenance
- Three sequence select inputs for program initiation by an external device
- CW, CCW limit and Home inputs

| Parameter | Value |
|----------------------------|--|
| Power Input - DC | 24–75 VDC @ 2A max |
| Performance | |
| Accuracy | ±5 arc min (0.0833°) typical, unloaded, bidirectional with Parker-supplied motors. Other motors may exhibit different absolute accuracy Loaded condition - in addition to unloaded accuracy, add 1 arc min (0.0167°) for each increment of load equal to 1% of the rated motor torque |
| Repeatability | ±5 arc sec (0.0014°) typical, unloaded - one revolution returning to start point from same direction |
| Hysteresis | Less than 2 arc min (0.0334°) unloaded, bidirectional |
| Resolution | 16 selectable options: 200, 400, 1000, 2000, 5000, 10000, 12800, 18000, 20000, 21600, 25000, 25400, 25600, 36000, 50000, 50800 |
| Waveform | Selectable - allows waveform shaping for optimum smoothness or relative accuracy. Pure sine; -4%, -6%, -8%, -10% 3rd harmonic |
| Amplifier | |
| Type | 20 kHz fixed frequency, variable duty cycle pulse width modulated (PWM) current controlled, bipolar chopper |
| Number of Phases | 2 |
| Output Current | Programmable, 0.15 - 7.5A/phase peak |
| Drive Supply Voltage | 24–75 VDC (dependent on external power supply) |
| Standby Current Reduction | 25%, 50% or 75% of selected motor current |
| Nominal Chopping Frequency | 20 kHz |
| Max Stepping Rate | 2 MHz max pulse rate; 50 rps max speed |
| Protection Circuits* | |
| Short Circuit | Phase-to-phase, phase-to-ground |
| Undervoltage | If DC supply drops below 24 VDC |
| Overtemperature | If internal air temperature exceeds 70°C |
| Environmental | |
| Operating temp. | 0°C to 50°C. Max allowable ambient temperature is 50°C. External heat sinking is required via the mounting surface or a suitable heatsink. Max. heatplate temperature 55°C |
| Storage temp. | -40°C to 85°C |
| Humidity | 0 to 95% Non-condensing |
| Physical | |
| Drive Dimensions | 127 x 91 x 41 mm |
| Weight | 0.32 kg |
| Motor | |
| Type | 2 phase hybrid; 4, 6 or 8 leads |
| Inductance Range | 0.2mH - 80mH |

OEM750

| | |
|-----------------|---|
| Step Input | High-going pulse, 200 nsec min width; max pulse rate is 2 MHz; User-supplied driver for the step inputs should be capable of providing up to 15mA |
| Direction Input | Logic High = positive (CW) rotation—3.5–5.0V; Logic Low = negative (CCW) rotation—0–0.4V User-supplied driver for the direction inputs should be capable of providing up to 15mA. The direction input must be stable for at least 200 µsec before the drive receives the first pulse |
| Fault Output | Open-Collector/Emitter, Vce = 35 VDC, Vce sat = 0.3 VDC, Ic = 10 mA (max) dissipation = 100 mW; Conducting = normal operation; Non conduction = drive fault |

OEM750X

| | |
|------------------------|---|
| RS-232C Interface | |
| Connection | 3-wire implementation (Tx, Rx, Gnd) |
| Parameters | 9,600 baud rate, 8 data bits, 1 stop bit, no parity |
| Configurations | Up to 8 OEM750X units can be controlled from a single host RS-232C port in daisy chain configuration |
| Inputs | |
| Sequence Select Inputs | Three inputs to be used to select and run motion programs and for interactive machine control; TTL-compatible** |
| Trigger Inputs | Three trigger inputs internally pulled up to 5V; sinking current is 1.2mA, TTL-compatible** |
| Limits and Home | Logic High = 2.0-5.0V; Logic Low = 0-0.8V |
| Encoder | |
| A, B and Z Channel | Single-ended, active high; Logic Low = 0-0.8V; Logic High = 2.0-5.0V (4.5mA sink) |
| Max Frequency | 160 kHz (pre-quadrature) |
| Min Pulse Width (Z) | 500 nsecs |
| Outputs | |
| 2 Programmable Outputs | Logic High = min. 4.26V (source -24 mA); Logic Low = max. 0.44V (sinks to 24 mA) |
| Fault Output | Logic Low = drive fault; Logic High = normal operation |

* Drive shuts down under conditions listed. Power must be cycled or drive reset to resume operation.

** TTL-compatible voltage levels; Low ≤0.4V; High ≥2.4V

OEM750/OEM750X dimensions (mm)

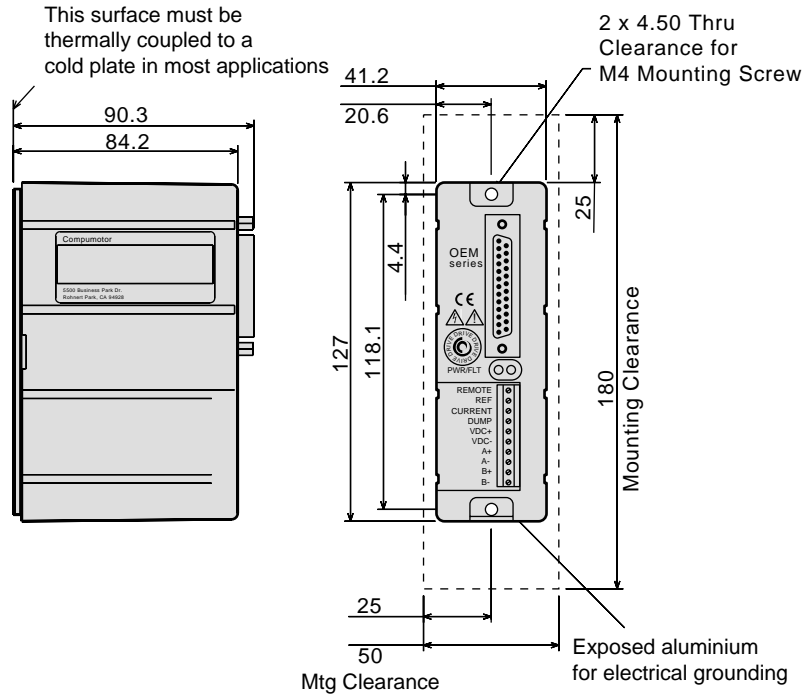

OEM750 drive connections

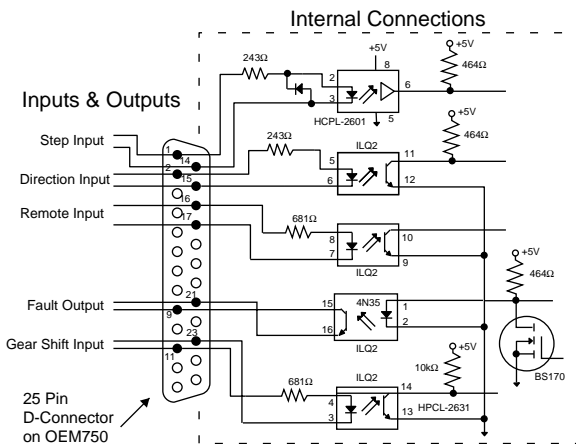

OEM750X drive connections

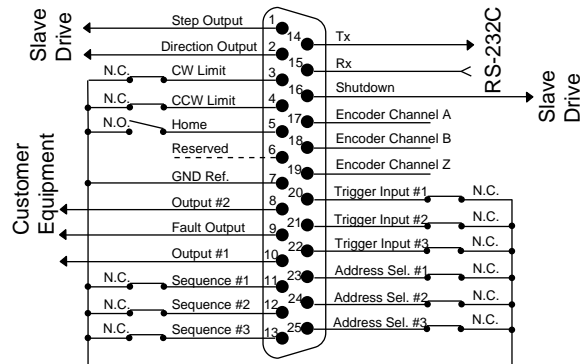

OEM750/OEM750X speed torque curves @ 75VDC

(Power curves are shown in blue)

Size 23 Frame*

Size 34 Frame

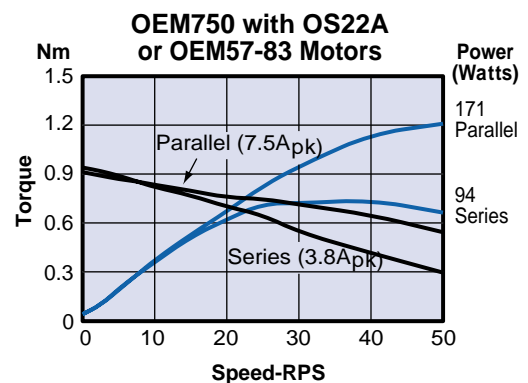
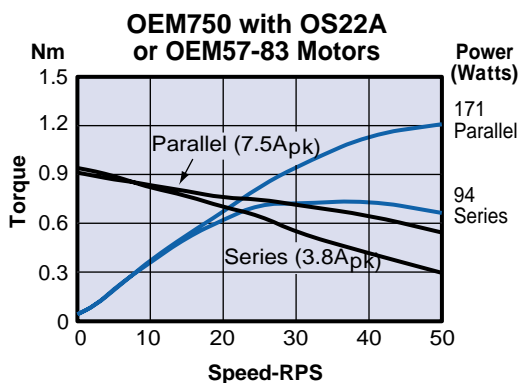
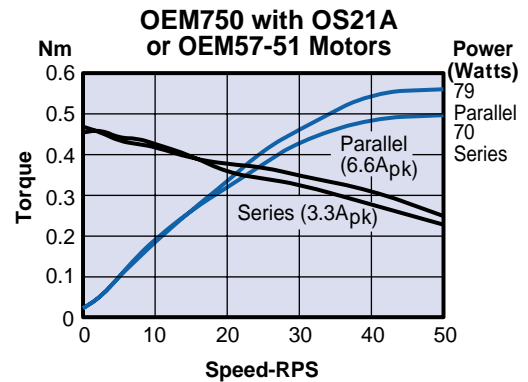
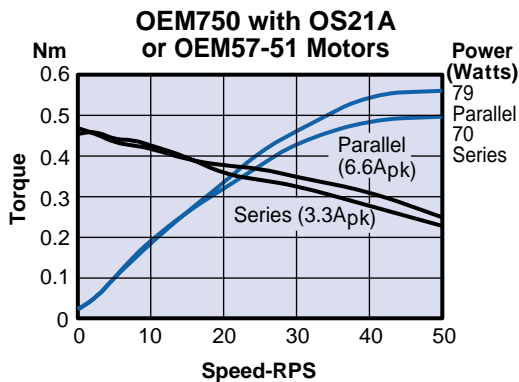
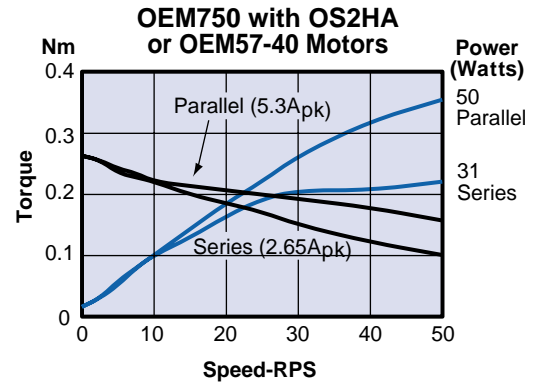
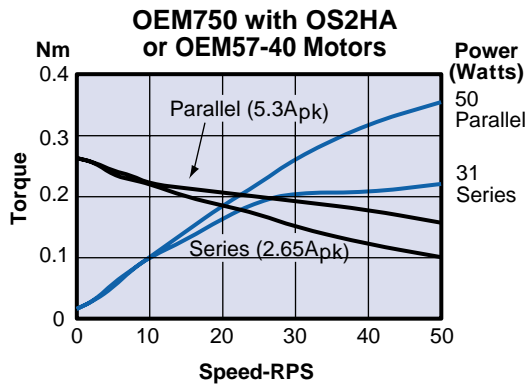

*Parallel connection consideration: for greater than 50% duty cycle above 5 rps, fan cooling the motor may be required.

Note: ±10% torque variance due to motor tolerance.

OEM750/OEM750X motor dimensions (mm)

Size 23 Frame, O Series and OEM57 motors

| Model | L max. |
|------------------|--------|
| OS2HA (OEM57-40) | 40.7 |
| OS21A (OEM57-51) | 52.4 |
| OS22A (OEM57-83) | 78.8 |

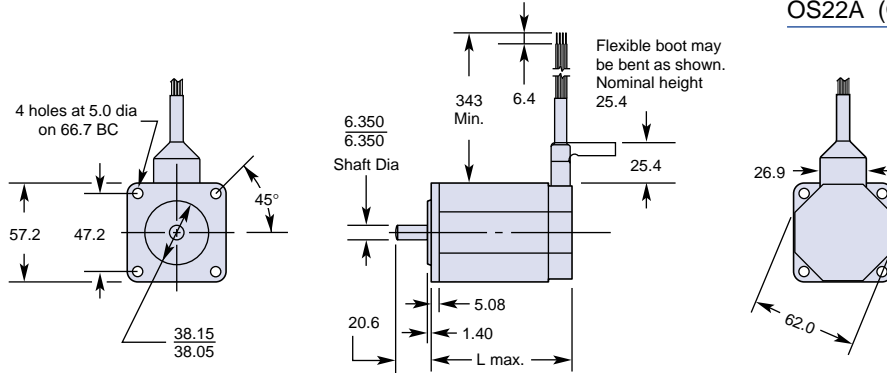

Size 34 Frame, R Series and OEM83 motors, regular construction

| Model | L max. |
|------------------------|--------|
| RS31B□□R10 (OEM83-62) | 65.54 |
| RS32B□□R10 (OEM83-93) | 95.51 |
| RS33B□□R10 (OEM83-135) | 128.53 |

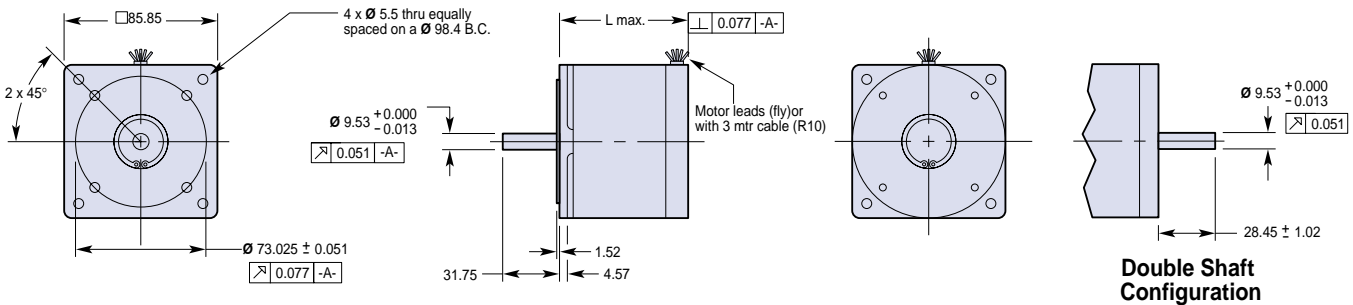

Size 34 Frame, R Series, end bell construction (NPS)

| Model | L max. | L2 |
|------------|--------|--------|
| RS31B□□NPS | 65.54 | 72.9 |
| RS32B□□NPS | 95.51 | 102.11 |
| RS33B□□NPS | 128.53 | 134.62 |

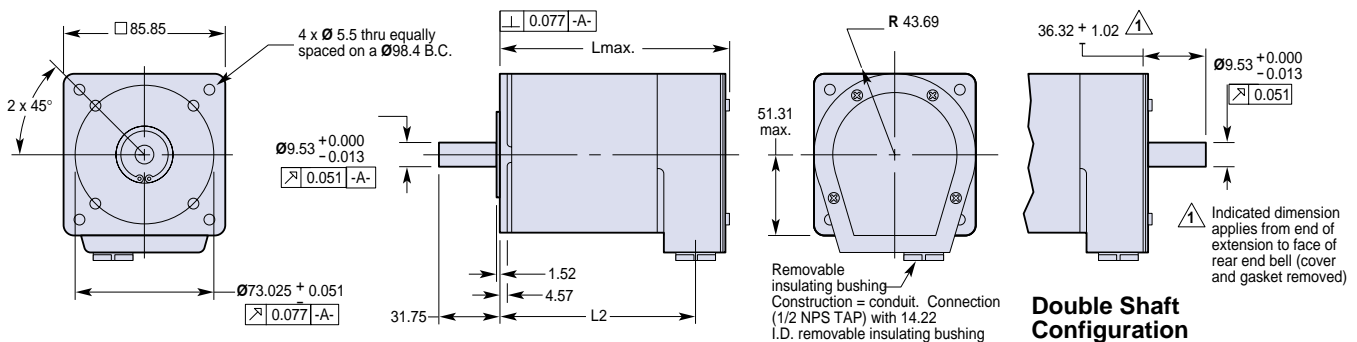

OEM750/OEM750X motor data

| | | Size 23 Frame | | | Size 34 Frame | | |
|--|----------|---------------|------------|------------|---------------|-----------|-----------|
| | | OS2HA | OS21A | OS22A | RS31B | RS32B | RS33B |
| Static torque, Nm | | 0.26 | 0.47 | 0.94 | 1.03 | 2.02 | 2.55 |
| Rotor inertia, kg-cm ² | | 0.070 | 0.119 | 0.253 | 0.583 | 1.195 | 1.757 |
| Current, Apk/Arms: | Series | 2.65/1.9 | 3.3/2.3 | 3.8/2.7 | 4.4/3.1 | 5.6/4.0 | 6.9/4.9 |
| | Parallel | 5.3/3.7 | 6.6/4.7 | 7.5/5.3 | | | |
| Inductance, mH: | Series | 1.7 | 1.8 | 2.8 | 2.9 | 2.9 | 2.4 |
| | Parallel | 0.4 | 0.4 | 0.7 | | | |
| Detent Torque, Nm | | 0.02 | 0.03 | 0.05 | 0.06 | 0.13 | 0.19 |
| Bearing Information | | | | | | | |
| Thrust Load, N | | 6.0 | 6.0 | 6.0 | 800 | 800 | 800 |
| Radial Load, N | | 90 | 90 | 90 | 160 | 160 | 160 |
| End Play, mm (Reversing load equal to 5N) | | 0.025 | 0.025 | 0.025 | 0.025 | 0.025 | 0.025 |
| Radial Play, mm (Per 2.5N load) | | 0.02 | 0.02 | 0.02 | 0.02 | 0.02 | 0.02 |
| Motor Weight, kg | | 0.45 | 0.68 | 1.14 | 1.45 | 2.41 | 3.45 |
| Certifications: UL recognized | | Pending | Pending | Pending | Yes | Yes | Yes |
| CE (LVD) | | Yes | Yes | Yes | Yes | Yes | Yes |
| CE (EMC & LVD) | | w/C10 kit* | w/C10 kit* | w/C10 kit* | w/C10kit | w/C10 kit | w/C10 kit |

*Provided EMD Installation Guidelines for 'motors with non removable cabling' are followed.

Motor ordering information

CE Size 23 Frame Motors

| Part No. | Description |
|--------------|--|
| OS2HA -□□□□□ | Standard, Size 23, half stack (57-40) A winding motor |
| OS21A -□□□□□ | Standard, Size 23, single stack (57-51) A winding motor |
| OS22A -□□□□□ | Standard, Size 23, double stack (57-83) A winding motor |

CE Size 34 Frame Motors

| Part No. | Description |
|--------------|---|
| RS21B -□□□□□ | Standard, Size 34, half stack (83-62) B winding motor |
| RS32B -□□□□□ | Standard, Size 34, single stack (83-93) B winding motor |
| RS33B-□□□□□ | Standard, Size 34, double stack (83-135) B winding motor |

Accessories

C10 - LVD/EMC motor cable kit (includes 3mtr cable, gland (360° shield connector), R-clamp and assembly instructions).

How to order CE motors

Size 23 Frame

| Series | Type | Frame Size | No. of Rotor Stacks | Winding Type | Shaft | Shaft Modification | Motor Construction/ Hookup | Motor Construction/ Hookup |
|---------------|--------------|------------------|--|--|--------------------------|-----------------------|--|---|
| 0 (Octagonal) | S = Standard | 2=Size 23 (2.5") | H = Half 1 = 1 Stack 2 = 2 Stack | A = 75DC winding (grey painted motors) | S = Single D = Double | N = Standard (smooth) | FLY = Regular construction with flying (8) leads | Blank = No feedback HJ = 512 ppr single-ended kit w/0.3m flying leads RE = 1000 ppr differential kit encoder w/line driver & 0.3m flying leads (call for availability) RC = 1000 ppr differential kit encoder w/line driver & 3m cable (call for availability) |

Size 34 Frame

| Series | Type | Frame Size | No. of Rotor Stacks | Winding Type | Shaft | Shaft Modification | Motor Construction/ Hookup | Encoder Option |
|-----------|--------------|-------------------|---|---|--------------------------|-----------------------|---|--|
| R (Round) | S = Standard | 2=Size 34 (3.38") | 1 = 1 Stack 2 = 2 Stack 3 = 3 Stack | B = 170VDC winding (black painted motors) | S = Single D = Double | N = Standard (smooth) | NPS = End bell/terminal board via 1/2" NPS pipe thread C10 = NPS option with (C10) LVD/EMC cable kit R10 = Regular construction with non-CE marked 3m cables (S/ZETA/QM motor construction - not CE marked) | Blank = No feedback EC = 1000 ppr differential encoder with line driver and 3m cable (E Series) |

Engineering solutions in motion control...

The performance requirements of today's automation tasks demand reliable, cost-effective solutions and the reassurance of competent technical backup. A comprehensive product range supported by highly-trained, experienced application engineers forms the basis of Parker's motion control capability.

With the combined resources of world-class companies like Digiplan, Compumotor, Hauser and Daedal, Parker can offer a range of automation products which is second to none. High-performance stepper and servo systems combined with powerful, flexible controllers are complemented by a wide selection of mechanical positioning systems. This

equipment is supplied and supported through a worldwide network of Automation Technology Centres, each with factory-trained staff who specialise in the application of high-technology motion control systems.

Our aim is to give customers a competitive advantage by providing top-grade equipment and unrivalled technical support. Whether the application is in industrial automation, production machinery, instrumentation or research, you can be certain that your system will be precision-engineered and backed by the Parker guarantee of quality and reliability.



Parker - we engineer solutions in motion control

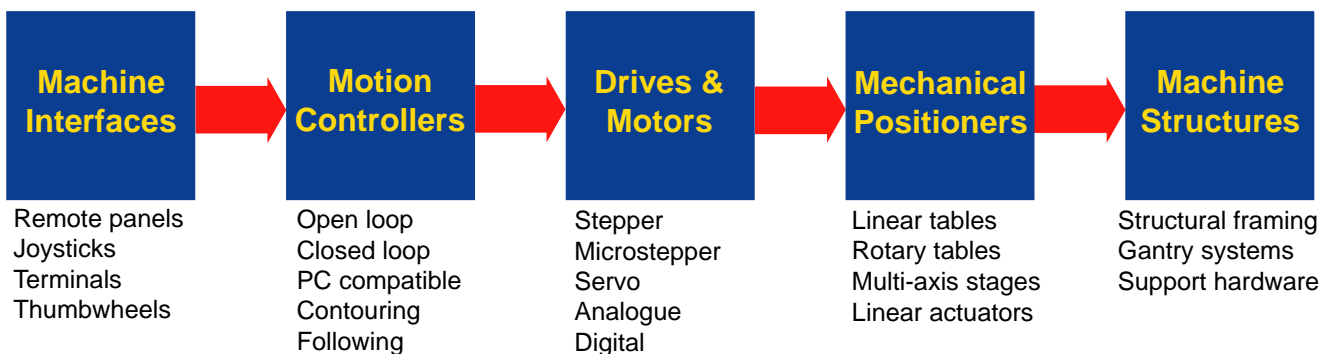

Parker Hannifin plc
Electromechanical Division - Digiplan
21 Balena Close
Poole, Dorset. BH17 7DX UK
Tel: +44 (0)1202 69 9000
Fax: +44 (0)1202 69 5750

Parker Hannifin GmbH
Electromechanical Division - Hauser
Robert-Bosch-Str. 22
D-77656 Offenburg, Germany
Tel: +49 (0)781 509-0
Fax: +49 (0)781 509-176