

H S M Drive

In preparing our new catalogue we have made every effort to present the information in a clear and concise manner. We hope you will find the format to be satisfactory, enabling you to quickly locate any required information. However if you have any suggestions for improvements we would be very pleased to receive them via our representative or direct to SUMITOMO CYCLO EUROPE.

Copyright Sumitomo Cyclo Europe 2002. All rights reserved.

Reproduction in part or whole is not permitted without our prior approval.

Whilst every care has been taken in preparation of this catalogue, no liability can be accepted for any errors or omissions.



Certificate No: FM 20793

Contents

GENERAL INFORMATION

Product Features 2
Taper-Grip® 4

SELECTION

Type Designation 8
Selection 9
Power Ratings 11

DIMENSIONS

Dimension Sheets 18
Output Bores 22
Input Shaft 25

OPTIONS

Motor Mounts..... 28
Screw Conveyors 30
Motorised Options 32
Backstop..... 33
Harsh Environment Sealing 33
Signature Service..... 34

INSTALLATION

Keyed Hub Reducer 38
Maintenance 39
Taper-Grip® Reducer..... 40
Lubrication 41
Backstop..... 42

PARTS CODES 45



SUMITOMO CYCLO EUROPE

H S M Drive

The New HSM gearbox is Sumitomo's new range of shaft mounted speed reducers. In general the gearbox is designed to be mounted directly on the machine shaft of the application and restrained by the use of a torque arm or flange thus eliminating the need for a coupling or chain drive. Along with the ratios available a wide selection of output speeds are achievable with the use of a belt drive to the input shaft.

Alternatively the gearbox can be driven directly from a hydraulic or electric motor using an input flange adapter. The new design incorporates many features as standard that were previously available as options. This new generation of gearboxes is available in thirteen case sizes achieving a maximum output torque of 44,000 Nm.



SUMITOMO CYCLO EUROPE

H S M Drive

1 Case Design - The gear case is manufactured from grey cast iron, precision bored and dowelled to ensure accurate assembly. There are thirteen case sizes available.

4 Oilseals - Oilseals are metal reinforced double lipped gaiter spring type as standard and taconite seals are available for harsh environments. All seals are available world wide.

2 Gears - The gears are helical designed to DIN/ISO and AGMA standards with a 25 degree pressure angle. They are manufactured from alloy steel, gas carburised and hardened, shaved and honed (profile ground on selected sizes) They are available in up to four ratios 5, 13, 20 and 25:1.

3 Bearings - The bearings used conform to the ISO dimension plan and are available world wide. The high speed and intermediary shafts are designed with roller bearings. The low speed shaft deep groove ball bearings, with taper roller bearings as an option.

5 Shafts - Shafts are machined from alloy steels and are precision ground on journals, gear seating and extensions. Tolerance and keyways conform to ISO standards.

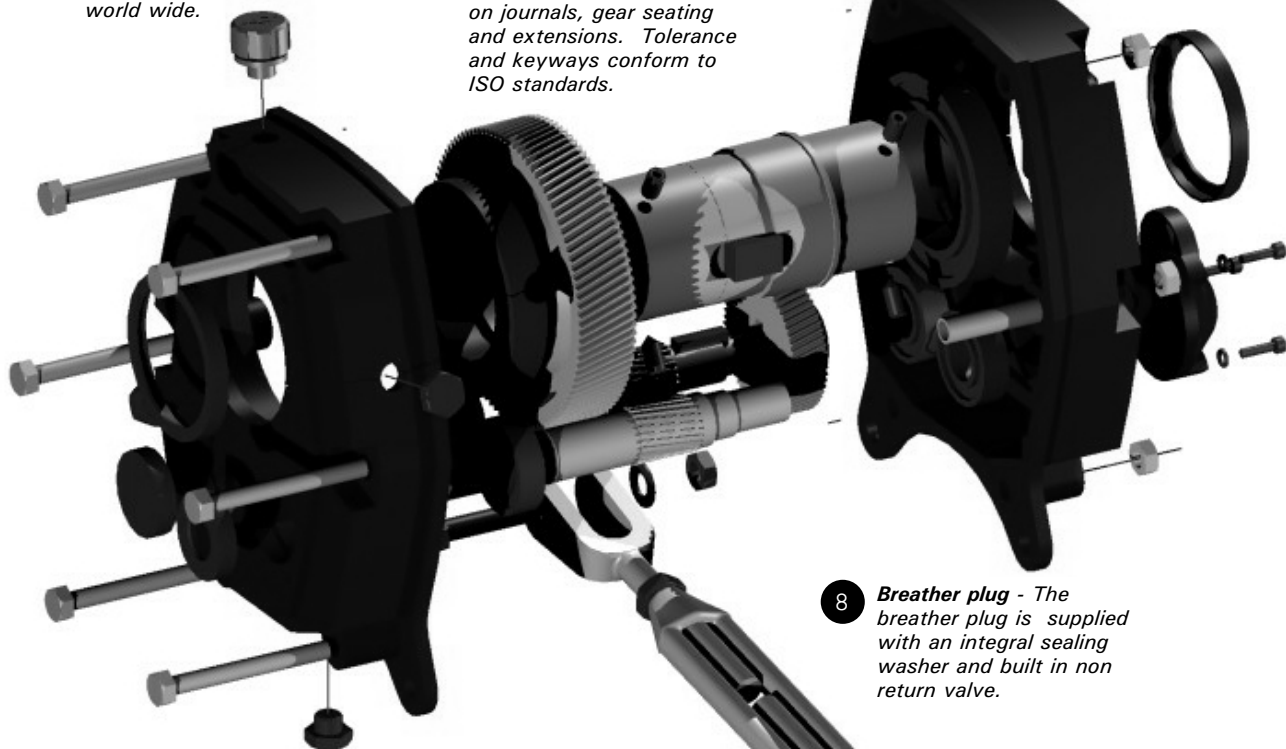

6 Output hubs - Output hubs are available with Taper Grip® or parallel bore, in metric or imperial. A wide choice of output bore diameters are available, see pages 22-23 for details. Alternative bores not listed can be considered.

7 Input shafts - Input shafts are available in both metric and imperial dimensions to ISO standards.

8 Breather plug - The breather plug is supplied with an integral sealing washer and built in non return valve.

9 Shaft End Caps - The rubberised shaft end caps are self sealing to standard ISO housing dimensions.

10 Plugs - The plugs are supplied with an integral sealing washer. The casing is machined for an excellent sealing surface.

11 Torque arm - The torque arm can be mounted on the casing using one of the two dedicated casing points thus avoiding the need to remove any case half fixings. The turnbuckle design allows for quick and easy adjustment of the belt system.

12 Backstop - The backstop is available for all sizes and ratios, and can also be retrofitted once the unit has been supplied.

13 Flange mounting - Is suitable for flange mounting directly to a machines framework by use of the tapped holes around the output hub. This flange mounting may permit the omission of a bearing from the application.

The HSM can be secured to the driven shaft by means of the Taper-Grip® bush which will transmit the torque and shock overload capacity of the selected gearbox.

The Taper-Grip® bush is a unique shaft locking system that overcomes the difficulties which can be experienced with other methods of securing the hub to the machine shaft. The Taper-Grip® bush allows for easy assembly and disassembly of the shaft mounted speed reducer, and because it generally does not use a key or keyway it avoids any type of fretting and corrosion.

The principle of using tapers to secure power transmission components has been established for many years and the Taper-Grip® bush system is based on well known locking capabilities of conventional taper fixings.

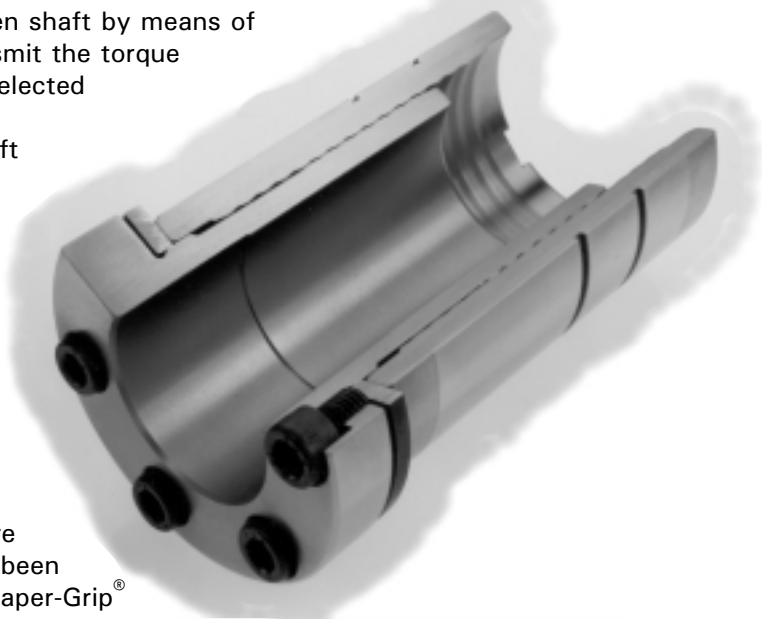

Features

- Requires no key or keyway.
- Resistant to fretting corrosion.
- Easy to assemble and position the HSM to the driven shaft.
- The bush can be used from either side of the gearbox as standard.
- Allows for the driven shaft diameter tolerances to be h11.
- Easy to remove the HSM from the driven shaft.
- Both metric and imperial shaft bores available.
- Wide selection of shaft diameters can be used.
- Taper-Grip® bush can be used with existing keyed shafts.

The Taper-Grip® bush has a series of short tapers in the form of a continuous helix. Figure 1 illustrates this and demonstrates how an optimum friction angle is used to reduce the radial dimension to a minimum.

The tapers are machined on the hub of the gearbox and the Taper-Grip® bush in the form of shallow screw threads, which enable the bush to be installed from either side of the gearbox. The bush is secured with screws acting against the wedging tapers on the screw threads.

The locking system is designed to secure the shaft mounted speed reducer to the driven shaft and provides a means to transmit the torque without the use of a key or keyway.

The bush can easily be installed on existing shafts that may already have a keyway, in which case the key will not be required.

figure 1

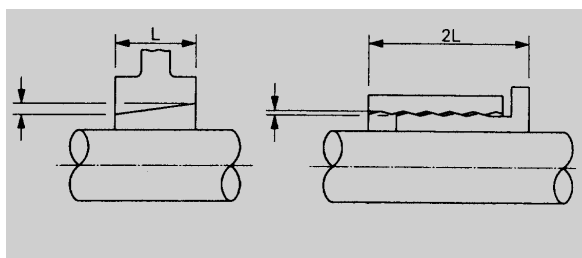

The ease of using the Taper-Grip® Bush

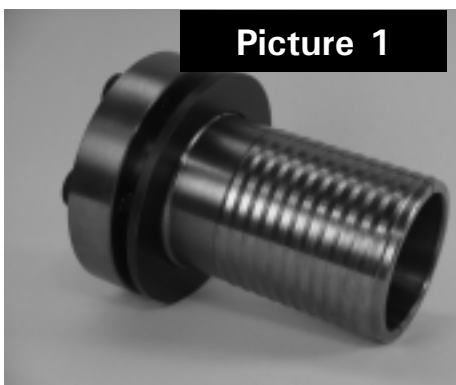

Picture 1

- 1 The only tools required for fitting the HSM gearbox with Taper-Grip® bush to the application is an allen key and torque wrench. The driven shaft needs to be in good condition, but no lubrication is necessary for the fitting of the gearbox to the shaft. The shaft must be free of any oil or grease.

- 2 The bush is fitted to the HSM before being offered to the application. It can then be slid on to the shaft with ease. The Taper-Grip® bush can be used on existing keyed shafts. There is no need to cover the existing keyway.

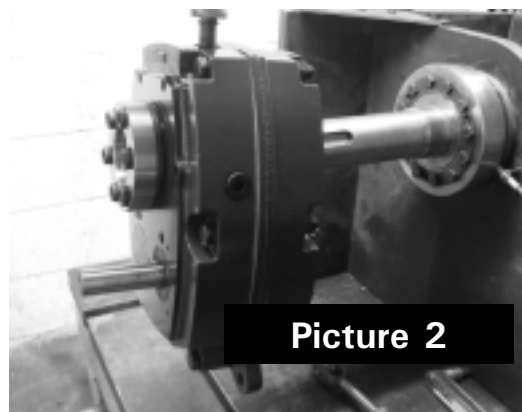

Picture 2

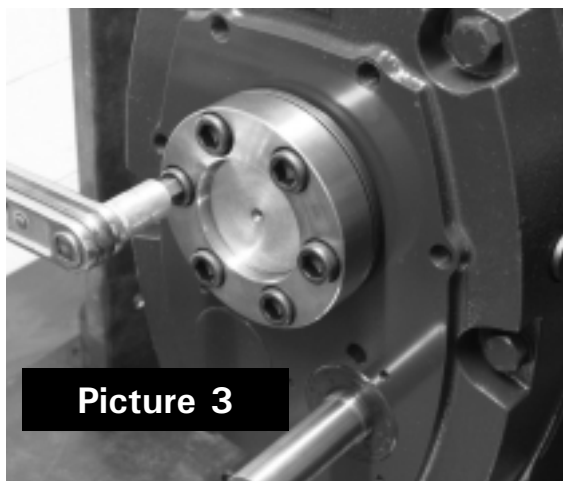

Picture 3

- 3 Once the HSM is in position, the allen key is used to tighten the cap head screws in the Taper-Grip®. These should be tightened to the set values.

That's how easy it is to use the
Taper-Grip® bush!

SUMITOMO CYCLO EUROPE

H S M Drive

**H S M Drive
Selection**

H S M Drive

Selection

Type Designation

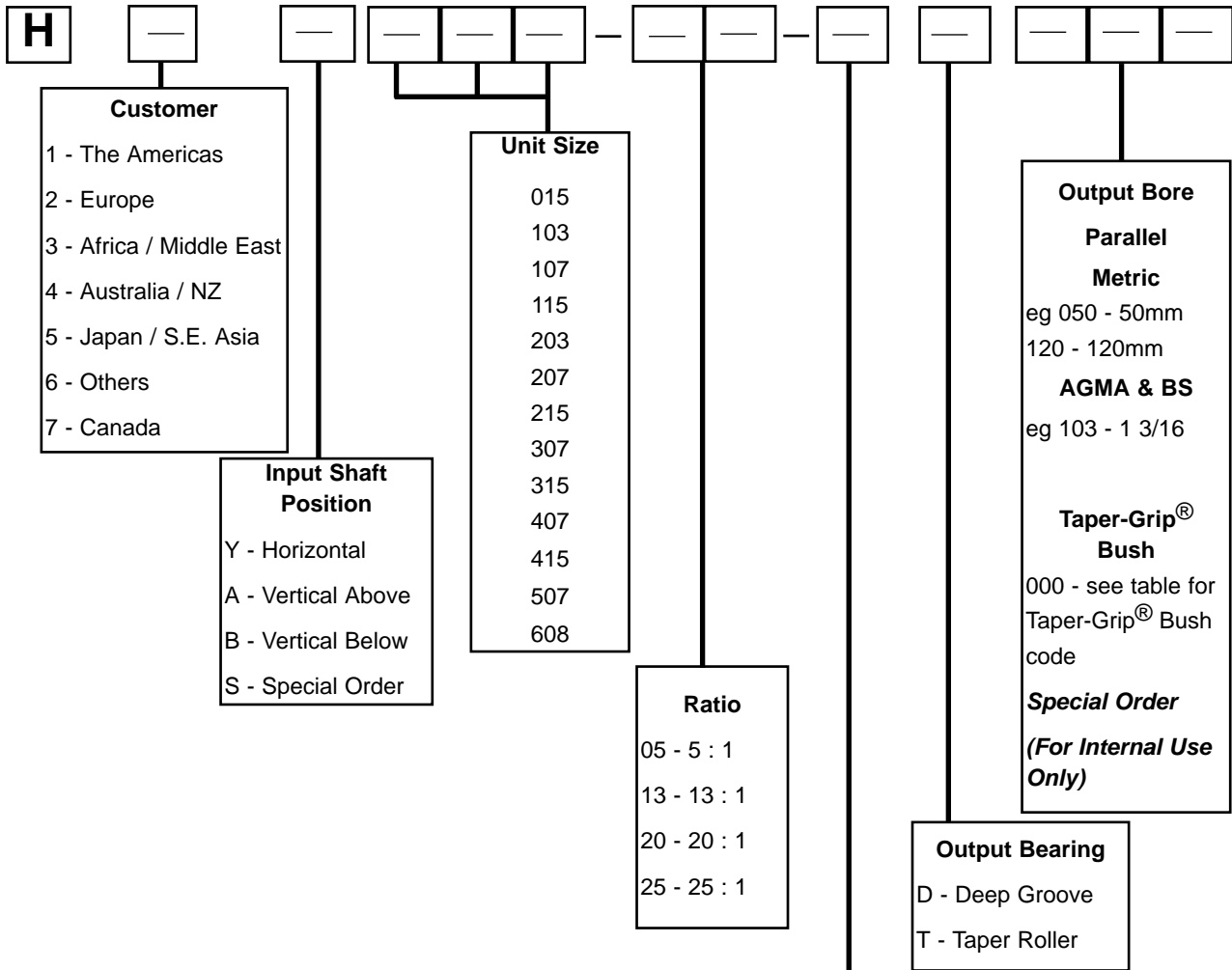

Taper-Grip® bush coding

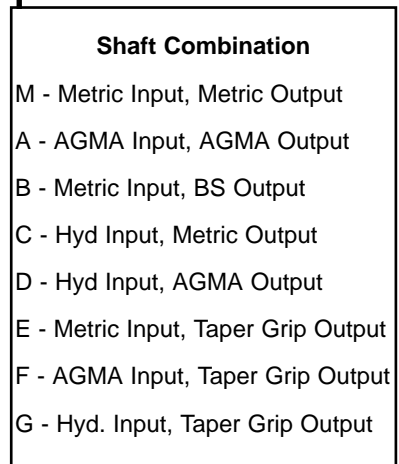
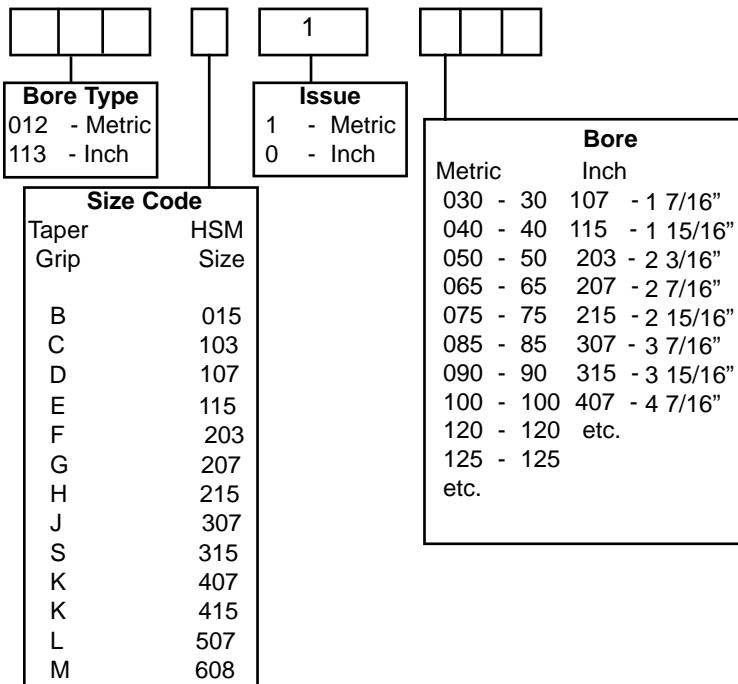

Gearbox Selection Procedure

Method A

(i) Service Factor

From page 10 locate the application type and, from the daily operational hours required, select the load classification (I, II or III).

(ii) Unit Selection

Refer to Class I, II or III selection tables on pages 11 through to 13. From the motor power and output speed required, select the unit size and ratio.

Note:

Gear units are momentarily capable of transmitting twice (2x) the rated capacity on start or during operation. For applications where momentary loads exceed a peak of 200% overload, the motor power used in the selection tables may be obtained by dividing the peak power by two.

Method B

(I) Service Factor

From page 10 locate the application type and, from the daily operational hours required, select the load classification (I, II or III). Using the table on page 10, read the service factor (fn1) associated with the load classification.

(ii) Design Power

Multiply the absorbed power (P1) (or motor power if absorbed power not known) by the service factor chosen in step (I). This represents the design power (Pd)

$$Pd = P1 \times fn1$$

(iii) Unit Selection

Using the value from step (ii), refer to the power rating tables on pages 14 and 15 and select the correct size of unit.

The choice of single or double reduction gearbox will be determined by the output speed required. The normal operating speeds for each of the gearboxes may be observed in the power rating tables.

Gearbox Selection Procedure - Examples

A Taper-Grip[®] Shaft Mounted Speed reducer is required for a uniformly loaded elevator which absorbs 3.6kW at 50 rpm. The prime mover is a 5HP (4kW) 4 pole direct on line start electric motor. The application requires the drive to run 24 hours/day.

Method A

(i) Service Factor

From page 10 the application type and operational hours result in a load classification of II.

(ii) Unit Selection

Referring to Class II selection tables on page 12, a motor power of 5HP and output speed of 50 shows the required unit is 115-25, 115-20 or 115-13.

Method B

(i) Service Factor

From page 10 the application type and operational hours result in a load classification of II. Using the table on page 10 the service factor is determined as:-

$$fn1 = 1.4$$

(ii) Design Power

The absorbed power P1 = 3.6 is multiplied by the service factor (fn1) to give the design power:-

$$Pd = 3.6 \times 1.4 = 5.04 \text{ kW}$$

(iii) Unit Selection

Locate the output speed in the first column of pages 14 or 15 and read across until the unit power exceeds the design power. A double reduction unit size 115 is selected with a rated power of 6.48 kW.

Power / Torque Conversions

Th = Torque (ft.lbf) Tm = Torque (Nm)
 Ph = Power (HP) Pm = Power (kW)
 n = speed (rpm)

$$Ph = \frac{(Th \times n)}{5250} \qquad Pm = \frac{(Tm \times n)}{9550}$$

Recommended Load Classification by Application

		U = uniform load H = heavy shocks M = moderate shocks R = consult SCE			
		Class Service Factors(fn¹)			
		I	II	III	
		=	=	=	
		1.0	1.4	2.0	
		Operational hours per day			
		< 10	10 -16	> 16	
		Operational hours per day			
		< 10	10 -16	> 16	
BRICK, CONCRETE STONE, CLAY					
Concrete mixer	M	II	II	III	
Stone crusher	H	III	III	III	
Hammer-/Ball-/Beater mills	H	III	III	III	
Inclined hoists	R				
Brick presses	H	III	III	III	
CONVEYORS - UNIFORMLY LOADED					
Belt conveyors	U	I	II	II	
Bucket conveyors	U	I	II	II	
Assembly lines	U	I	II	II	
Chain conveyors	U	I	II	II	
Freight elevators	U	I	II	II	
Apron conveyors	U	I	II	II	
Screw conveyors	U	I	II	II	
CONVEYORS - HEAVY DUTY					
Belt conveyors	M	II	II	III	
Bucket conveyors	M	II	II	III	
Assembly lines	M	II	II	III	
Chain conveyors	M	II	II	III	
Freight elevators	M	II	II	III	
Apron conveyors	M	II	II	III	
Screw conveyors	M	II	II	III	
CRANES					
Traction gears	R			Consult SCE	
Hoists	M	II	II	III	
Slewing gears	R			Consult SCE	
EXCAVATOR					
Traction gears	R			Consult SCE	
Cutter head gears	H	III	III	III	
Slewing gears	R			Consult SCE	
Winches	M	II	II	III	
FOOD AND SUGAR INDUSTRY					
Kneading machines	M	II	II	III	
Cooker	U	I	II	III	
Sugar crushing mills	M	II	II	III	
Sugar beet cutter	M	II	II	III	
Sugar cane mills	M	II	II	III	
METAL WORKING MACHINES					
Bending/straightening mach.	M	II	II	III	
Presses	H	III	III	III	
Plate shears	H	III	III	III	
Machine tools					
- main drive	M	II	II	III	
- auxiliary drive	M	II	II	III	
MIXERS AND AGITATORS					
- for constant viscosity	U	I	II	III	
- for variable viscosities	M	II	II	III	
PAPER INDUSTRY					
Bleaching apparatus	U	I	II	II	
Coucher	R			Consult SCE	
Machine glazing cylinders	R			Consult SCE	
Beaters	M/H	II	III	III	
Calenders	M	II	II	III	
Wet presses	M/H	II	III	III	
Drying drums	M	II	II	III	
PUMPS					
Centrifugal pumps	R			Consult SCE	
Plunger pumps	R			Consult SCE	
ROLLING MILLS					
Plate shears	R			Consult SCE	
Plate turners	M/H	II	III	III	
Roller tables	H	III	III	III	
Wire wheels	R			Consult SCE	
Descaling machines	M	II	II	III	
Chain transfer	M	II	II	III	
Cooling beds	M	II	II	III	
Cross transfer	R			Consult SCE	
Slab transport	R			Consult SCE	
Tube straightening machines	R			Consult SCE	
Continuous casting machines	R			Consult SCE	
Roller adjustment drives	M	II	II	III	
RUBBER AND PLASTIC MACHINES					
Extruders	U/M	I	II	III	
Calenders	M	II	II	III	
Kneading machines	H	III	III	III	
TEXTILE INDUSTRY					
Dyeing machines	M	II	II	III	
Tanning vats	M	II	II	III	
Calenders	M	II	II	III	
Willows	M	II	II	III	
Looms	M	II	II	III	
WATER TREATMENT PLANTS					
Aerators	R			Consult SCE	
Filter presses	M	II	II	III	
Mixer	M	II	II	III	
Scraper/Thickener	M	II	II	III	
Screw pumps	M	II	II	III	

Output Size. RPM No.	Output Size. RPM No.	Output Size. RPM No.	Output Size. RPM No.	Output Size. RPM No.	Output Size. RPM No.	Output Size. RPM No.
1/4 HP (.18kW) Motor	3 HP (2.2kW) Motor	10 HP (7.5kW) Motor	30 HP (22kW) Motor	60 HP (45kW) Motor	125 HP (90kW) Motor	
10-100 103-25 015-20 015-13	10-11 207-25 207-20 207-13	10-15 307-25 307-20 307-13	10-11 507-25 507-20 507-13	10-17 608-25 608-20 608-13	21-39 608-25 608-20 608-13	
1/3 HP (.25kW) Motor						
101-400 015-05	12-15 203-25 203-20 203-13	16-21 215-25 215-20 215-13	12-15 415-25 415-20 415-13	18-25 507-25 507-20 507-13	40-58 507-25 507-20 507-13	
1/2 HP (.37kW) Motor						
10-100 103-25 015-20 015-13	16-24 115-25 115-20 115-13	22-37 207-25 207-20 207-13	16-21 407-25 407-20 407-13	26-31 415-25 415-20 415-13	59-63 507-13 64-79 415-13 80-100 407-13	
3/4 HP (.55kW) Motor						
101-400 015-05	25-39 107-25 107-20 107-13	38-61 203-25 203-20 203-13	22-27 315-25 315-20 315-13	32-44 407-25 407-20 407-13	101-119 407-05 120-199 315-05 200-370 307-05	
1 HP (.75kW) Motor						
10-13 103-25 103-20 103-13	40-84 103-25 103-20 103-13	62-100 115-25 115-20 115-13	28-45 307-25 307-20 307-13	45-65 315-25 315-20 315-13	371-400 307-05*	
1 1/2 HP (1.1kW) Motor						
101-400 015-05	85-100 103-25 015-20 015-13	101-109 115-05 110-239 107-05 240-400 103-05	46-76 215-25 215-20 215-13	66-74 307-25 307-20 307-13	26-48 608-25 608-20 608-13	
2 HP (1.5kW) Motor						
10-11 107-25 107-20 107-13	101-400 015-05	15 HP (11kW) Motor	77-85 207-25 207-20 207-13	75-100 307-13 101-119 307-05 120-219 215-05	59-100 507-13 101-168 407-05 169-269 315-05	
3 HP (2.2kW) Motor						
12-19 103-25 103-20 103-13	10-11 215-25 215-20 215-13	10-11 407-25 407-20 407-13	86-100 207-13	220-400 207-05	270-295 307-05*	
4 HP (3.0kW) Motor						
20-100 103-25 015-20 015-13	12-17 207-25 207-20 207-13	12-14 315-25 315-20 315-13	101-179 207-05 180-309 203-05 310-400 115-05	13-23 608-25 608-20 608-13	200 HP Motor 36-54 608-25 608-20 608-13	
5 HP (3.7kW) Motor						
101-400 015-05	18-25 203-25 203-20 203-13	15-21 307-25 307-20 307-13	10-11 608-25 608-20 608-13	24-33 507-25 507-20 507-13	55-68 608-13 69-78 507-13 79-82 507-13*	
7.5 HP (5.5kW) Motor						
10-13 107-25 107-20 107-13	26-41 115-25 115-20 115-13	22-32 215-25 215-20 215-13	12-17 507-25 507-20 507-13	34-41 415-25 415-20 415-13	170-250 407-05 251-257 407-05*	
10 HP (7.5kW) Motor						
14-25 103-25 103-20 103-13	42-79 107-25 107-20 107-13	33-61 207-25 207-20 207-13	18-21 415-25 415-20 415-13	42-57 407-25 407-20 407-13	258-280 315-05 281-320 315-05*	
15 HP (11kW) Motor						
26-100 103-25 015-20 015-13	80-100 103-25 103-20 103-13	62-95 203-25 203-20 203-13	22-27 407-25 407-20 407-13	58-78 315-25 315-20 315-13	321-370 407-05*	
20 HP (15kW) Motor						
101-400 015-05	101-159 103-05 160-400 015-05	95-100 115-25 115-20 115-13	28-39 315-25 315-20 315-13	78-84 315-13 85-100 307-13 101-179 307-05	47-54 608-25 608-20 608-13	
30 HP (22kW) Motor						
10-13 115-25 115-20 115-13	10-11 307-25 307-20 307-13	101-219 115-05 220-400 107-05	40-69 307-25 307-20 307-13	180-309 215-05 320-400 207-05	55-78 608-13 79-95 608-13*	
40 HP (30kW) Motor						
14-19 107-25 107-20 107-13	12-15 215-25 215-20 215-13	10-11 415-25 415-20 415-13	70-80 215-25 215-20 215-13	17-30 608-25 608-20 608-13	239-250 407-05 251-270 407-05*	
50 HP (37kW) Motor						
20-39 103-25 103-20 103-13	16-27 207-25 207-20 207-13	12-14 407-25 407-20 407-13	81-100 215-13 101-109 215-05 110-269 207-05	31-47 507-25 507-20 507-13	300 HP Motor 58-78 608-13 79-83 608-13*	
60 HP (45kW) Motor						
40-100 103-25 015-20 015-13	28-41 203-25 203-20 203-13	15-18 315-25 315-20 315-13	270-400 203-05	48-59 415-25 415-20 415-13		
75 HP (55kW) Motor						
101-400 015-05	42-77 115-25 115-20 115-13	19-28 307-25 307-20 307-13	10-15 608-25 608-20 608-13	60-74 407-25 407-20 407-13		
100 HP (75kW) Motor						
10-11 203-25 203-20 203-13	78-100 107-25 107-20 107-13	29-42 215-25 215-20 215-13	16-21 507-25 507-20 507-13	75-80 407-13 81-100 315-13 101-139 315-05		
150 HP (110kW) Motor						
12-17 115-25 115-20 115-13	101-149 107-05 150-319 103-05 320-400 015-05	43-84 207-25 207-20 207-13	22-25 415-25 415-20 415-13	140-272 307-05 273-380 215-05 381-400 215-05*		
200 HP Motor						
18-25 107-25 107-20 107-13		85-100 203-25 203-20 203-13	26-33 407-25 407-20 407-13			
250 HP Motor						
26-53 103-25 103-20 103-13		101-169 203-05 170-329 115-05 330-400 107-05	34-51 315-25 315-20 315-13			
300 HP Motor						
54-100 103-25 015-20 015-13			52-74 307-25 307-20 307-13			
350 HP Motor						
101-400 015-05			75-84 307-13 85-100 215-13 101-162 215-05 163-369 207-05 370-400 203-05			

Key
* indicates that power is constrained by thermal limitations. Please consult for effect on using cooling fans.

<i>Output Size. RPM No.</i>	<i>Output Size. RPM No.</i>	<i>Output Size. RPM No.</i>	<i>Output Size. RPM No.</i>	<i>Output Size. RPM No.</i>	<i>Output Size. RPM No.</i>	<i>Output Size. RPM No.</i>	<i>Output Size. RPM No.</i>
1/4 HP (.18kW) Motor	2 HP (1.5kW) Motor	7 1/2 HP (5.5kW)	20 HP (15kW) Motor	50 HP (37kW) Motor	100 HP (75kW) Motor		
10-100 103-25 015-20 015-13	10-11 207-25 207-20 207-13	10-11 315-25 315-20 315-13	10-11 507-25 507-20 507-13	12-21 608-25 608-20 608-13	24-45 608-25 608-20 608-13		
1/3 HP (.25kW) Motor	12-15 203-25 203-20 203-13	12-15 307-25 307-20 307-13	12-15 415-25 415-20 415-13	22-31 507-25 507-20 507-13	46-58 507-25 507-20 507-13		
10-11 103-25 103-20 103-13	16-23 115-25 115-20 115-13	16-21 215-25 215-20 215-13	16-19 407-25 407-20 407-13	32-37 415-25 415-20 415-13	59-77 507-13 78-89 415-13 90-100 407-13		
12-100 103-25 015-20 015-13	24-37 107-25 107-20 107-13	22-39 207-25 207-20 207-13	20-25 315-25 315-20 315-13	38-53 407-25 407-20 407-13	101-149 407-05 150-239 315-05 240-320 307-05		
101-400 015-05	38-77 103-25 103-20 103-13	40-65 203-25 203-20 203-13	26-41 307-25 307-20 307-13	54-78 315-25 315-20 315-13	321-400 307-05 *		
1/2 HP (.37kW) Motor	78-100 103-25 015-20 015-13	66-100 115-25 115-20 115-13	42-69 215-25 215-20 215-13	79 315-13 80-100 307-13 101-159 307-05	125 HP (90kW) Motor		
10-17 103-25 103-20 103-13	101-400 015-05	101-119 115-05 120-249 107-05	70-85 207-25 207-20 207-13	160-279 215-05 280-400 207-05	32-54 608-25 608-20 608-13		
18-100 103-25 015-20 015-13	3 HP (2.2kW) Motor	250-400 103-05	86-100 207-13 101-159 207-05 160-279 203-05	60 HP (45kW) Motor	55-57 608-13 58-85 507-13 86-100 507-13 *		
101-400 015-05	10-15 207-25 207-20 207-13	10 HP (7.5kW) Motor	280-400 115-05	14-25 608-25 608-20 608-13	140-209 407-05 210-370 315-05 371-400 315-05 *		
3/4 HP (.55kW) Motor	16-21 203-25 203-20 203-13	10-11 407-25 407-20 407-13	30 HP (22kW) Motor	26-37 507-25 507-20 507-13	150 HP (110kW) Motor		
10-13 107-25 107-20 107-13	22-33 115-25 115-20 115-13	12-13 315-25 315-20 315-13	10-11 608-25 608-20 608-13	38-49 415-25 415-20 415-13	38-54 608-25 608-20 608-13		
14-27 103-25 103-20 103-13	34-65 107-25 107-20 107-13	14-21 307-25 307-20 307-13	12-17 507-25 507-20 507-13	50-69 407-25 407-20 407-13	55-73 608-13 74-78 507-13 79-100 507-13		
28-100 103-25 015-20 015-13	66-100 103-25 103-20 103-13	22-29 215-25 215-20 215-13	18-21 415-25 415-20 415-13	70-78 315-25 315-20 315-13	190-279 407-05 280-300 315-05 301-400 315-05 *		
101-400 015-05	101-129 103-05 130-400 015-05	30-57 207-25 207-20 207-13	22-29 407-25 407-20 407-13	79-94 315-13 95-100 307-13 101-219 307-05	301-400 315-05 *		
1 HP (.75kW) Motor	5 HP (4kW) Motor	58-89 203-25 203-20 203-13	30-41 315-25 315-20 315-13	95-100 307-13 101-219 307-05 220-359 215-05	200 HP Motor		
10-11 115-25 115-20 115-13	10-11 307-25 307-20 307-13	90-100 115-25 115-20 115-13	42-77 307-25 307-20 307-13	360-390 207-05 391-400 207-05	54 608-25 608-20 608-13		
12-19 107-25 107-20 107-13	12-15 215-25 215-20 215-13	101-199 115-05 200-369 107-05	78-80 215-25 215-20 215-13	75 HP (55kW) Motor	55-85 608-13 86-100 608-13 *		
20-37 103-25 103-20 103-13	16-25 207-25 207-20 207-13	370-400 103-05	81-100 215-13 101-119 215-05 120-289 207-05	18-31 608-25 608-20 608-13	250 HP Motor		
38-100 103-25 015-20 015-13	26-37 203-25 203-20 203-13	15 HP (11kW) Motor	290-400 203-05	32-49 507-25 507-20 507-13	74-78 608-13 79-100 608-13 *		
101-400 015-05	38-69 115-25 115-20 115-13	10-11 415-25 415-20 415-13	40 HP (30kW) Motor	50-65 415-25 415-20 415-13			
1 1/2 HP (1.1kW)	70-100 107-25 107-20 107-13	12-15 407-25 407-20 407-13	10-17 608-25 608-20 608-13	66-74 407-25 407-20 407-13			
10-11 203-25 203-20 203-13	101-129 107-05 130-289 103-05	16-19 315-25 315-20 315-13	18-23 507-25 507-20 507-13	75-89 407-13 90-100 315-13 101-149 315-05			
12-17 115-25 115-20 115-13	290-400 015-05	20-29 307-25 307-20 307-13	24-29 415-25 415-20 415-13	150-299 307-05 300-360 215-05 361-400 215-05 *			
18-27 107-25 107-20 107-13		30-45 215-25 215-20 215-13	30-39 407-25 407-20 407-13				
28-57 103-25 103-20 103-13		46-85 207-25 207-20 207-13	40-61 315-25 315-20 315-13				
58-100 103-25 015-20 015-13		86-89 207-13 90-100 203-25 203-20 203-13	62-74 307-25 307-20 307-13				
101-400 015-05		101-189 203-05 190-349 115-05 350-400 107-05	75-100 307-13 101-109 307-05 110-199 215-05 200-400 207-05				

Key
* indicates that power is constrained by thermal limitations. Please consult for effect on using cooling fans.

Output Size. RPM No.	Output Size. RPM No.	Output Size. RPM No.	Output Size. RPM No.	Output Size. RPM No.	Output Size. RPM No.	Output Size. RPM No.					
1/4 HP (.18kW) Motor		1 1/2 HP (1.1kW) Motor		5 HP (4kW) Motor		15 HP (11kW) Motor		30 HP (22KW) Motor		60 HP (45KW) Motor	
10-13	103-25 103-20 103-13	10-11	207-25 207-20 207-13	10-15	307-25 307-20 307-13	10-11	507-25 507-20 507-13	10-17	608-25 608-20 608-13	22-37	608-25 608-20 608-13
14-100	103-25 015-20 015-13	12-15	203-25 203-20 203-13	16-21	215-25 215-20 215-13	12-15	415-25 415-20 415-13	18-25	507-25 507-20 507-13	38-61	507-25 507-20 507-13
101-400	015-05	16-25	115-25 115-20 115-13	22-37	207-25 207-20 207-13	16-21	407-25 407-20 407-13	26-31	415-25 415-20 415-13	62	415-25 415-20 415-13
1/3 HP (.25kW) Motor		2 HP (1.5KW) Motor		7 1/2 HP (5.5kW) Motor		20 HP (15kW) Motor		40 HP (30KW) Motor		75 HP (55KW) Motor	
10-17	103-25 103-20 103-13	26-39	107-25 107-20 107-13	10-11	407-25 407-20 407-13	78-85	207-25 207-20 207-13	75-100	307-13 307-05 215-05	26-49	608-25 608-20 608-13
18-100	103-25 015-20 015-13	40-84	103-25 103-20 103-13	12-15	315-25 315-20 315-13	101-179	207-05 203-05 115-05	14-23	608-25 608-20 608-13	50-58	507-25 507-20 507-13
101-400	015-05	85-100	103-25 015-20 015-13	16-21	307-25 307-20 307-13	180-309	203-05 115-05	14-23	608-25 608-20 608-13	59-79	507-13 415-13 415-13*
1/2 HP (.37kW) Motor		3 HP (2.2KW) Motor		10 HP (7.5kW) Motor		50 HP (37KW) Motor		100 HP (75KW) Motor		150 HP (110KW) Motor	
10-13	107-25 107-20 107-13	22-33	115-25 115-20 115-13	10-11	415-25 415-20 415-13	10-11	608-25 608-20 608-13	24-37	507-25 507-20 507-13	38-54	608-25 608-20 608-13
14-25	103-25 103-13	34-57	107-25 107-20 107-13	12-15	315-25 315-20 315-13	12-17	507-25 507-20 507-13	38-45	415-25 415-20 415-13	55-69	608-13 507-13 507-13*
26-100	103-25 015-20 015-13	58-100	103-25 103-20 103-13	16-21	307-25 307-20 307-13	18-21	415-25 415-20 415-13	46-65	407-25 407-20 407-13	70-80	507-13 507-13 507-13*
101-400	015-05	101-119	103-05 120-400	22-31	215-25 215-20 215-13	22-27	407-25 407-20 407-13	66-78	315-25 315-20 315-13	81-100	507-13 507-13 507-13*
3/4 HP (.55KW) Motor		4 HP (3.0KW) Motor		15 HP (11kW) Motor		30 HP (22KW) Motor		60 HP (45KW) Motor		125 HP (90KW) Motor	
10-13	115-25 115-20 115-13	10-13	215-25 215-20 215-13	10-11	415-25 415-20 415-13	10-11	608-25 608-20 608-13	24-37	507-25 507-20 507-13	50-54	608-25 608-20 608-13
14-19	107-25 107-20 107-13	14-21	207-25 207-20 207-13	12-15	407-25 407-20 407-13	40-69	307-25 307-20 307-13	38-45	415-25 415-20 415-13	55-95	608-13 608-13 608-13*
20-39	103-25 103-20 103-13	58-100	103-25 103-20 103-13	16-19	315-25 315-20 315-13	70-80	215-25 215-20 215-13	32-49	507-25 507-20 507-13	96-100	608-13 608-13 608-13*
40-100	103-25 015-20 015-13	101-119	103-05 120-400	22-31	215-25 215-20 215-13	81-100	215-25 215-20 215-13	32-49	507-25 507-20 507-13	240-250	407-05 407-05*
1 HP (.75kW) Motor		5 HP (4kW) Motor		15 HP (11kW) Motor		30 HP (22KW) Motor		60 HP (45KW) Motor		125 HP (90KW) Motor	
10-11	203-25 203-20 203-13	10-11	207-25 207-20 207-13	10-11	415-25 415-20 415-13	10-11	608-25 608-20 608-13	24-37	507-25 507-20 507-13	251-400	407-05 407-05*
12-17	115-25 115-20 115-13	22-31	203-25 203-20 203-13	12-15	407-25 407-20 407-13	12-17	507-25 507-20 507-13	38-45	415-25 415-20 415-13	251-400	407-05 407-05*
18-25	107-25 107-20 107-13	32-53	115-25 115-20 115-13	16-19	315-25 315-20 315-13	101-109	215-05 207-05	32-49	507-25 507-20 507-13	251-400	407-05 407-05*
26-53	103-25 103-20 103-13	54-94	107-25 107-20 107-13	20-29	307-25 307-20 307-13	110-269	207-05	50-61	415-25 415-20 415-13	251-400	407-05 407-05*
54-100	103-25 015-20 015-13	95-100	103-25 103-20 103-13	30-45	215-25 215-20 215-13	270-400	203-05	50-61	415-25 415-20 415-13	251-400	407-05 407-05*
101-400	015-05	101-229	103-05 230-400	46-84	207-25 207-20 207-13	270-400	203-05	62-74	407-25 407-20 407-13	251-400	407-05 407-05*
				85-100	203-25 203-20 203-13			75-84	407-13		
				101-169	203-05			85-100	315-13		
				170-329	115-05			101-139	315-05		
				330-400	107-05			140-279	307-05		
								280-400	215-05		

Key
* indicates that power is constrained by thermal limitations. Please consult for effect on using cooling fans.

Power Ratings [kW] 5:1 units (Single Reduction)

Output min-1	015	103	107	115	203	207	215	307	315	407
100	2.68	4.62	7.24	11.36	16.64	28.80	41.3	63.5	86.4	113.7
110	2.87	4.84	7.58	11.89	17.42	30.14	43.3	66.5	90.4	119.0
120	3.13	5.05	7.91	12.42	18.20	31.48	45.2	69.5	94.5	124.3
130	3.36	5.27	8.25	12.95	18.97	32.83	47.1	72.4	98.5	129.7
140	3.56	5.49	8.59	13.48	19.75	34.17	49.1	75.4	102.5	135.0
150	3.62	5.70	8.93	14.01	20.53	35.52	51.0	78.4	106.5	140.3
160	3.73	5.92	9.27	14.54	21.30	36.86	52.9	81.3	110.6	145.6
170	3.83	6.13	9.60	15.07	22.08	38.20	54.9	84.3	114.6	150.9
180	3.94	6.35	9.94	15.60	22.86	39.55	56.8	87.3	118.6	156.2
190	4.04	6.57	10.28	16.13	23.63	40.89	58.7	90.2	122.7	161.5
200	4.20	6.78	10.62	16.66	24.41	42.24	60.6	93.2	126.7	166.8
210	4.31	7.00	10.95	17.19	25.19	43.58	62.6	96.2	130.7	172.1
220	4.41	7.21	11.29	17.72	25.96	44.92	64.5	99.1	134.8	177.4
230	4.53	7.43	11.63	18.25	26.74	46.27	66.4	102.1	138.8	182.7
240	4.66	7.64	11.97	18.78	27.52	47.61	68.4	105.0	142.8	188.0
250	4.78	7.86	12.31	19.31	28.29	48.95	70.3	108.0	146.9	193.3
260	4.89	8.08	12.64	19.84	29.07	50.30	72.2	111.0	150.9	195.5
270	5.04	8.29	12.98	20.37	29.85	51.64	74.1	113.9	154.9	189.0
280	5.20	8.51	13.32	20.90	30.62	52.99	76.1	115.9	159.0	184.0
290	5.36	8.72	13.66	21.43	31.40	54.33	78.0	113.5	160.2	180.3
300	5.46	8.94	13.99	21.96	32.18	55.67	79.9	111.8	157.9	177.6
310	5.62	9.15	14.33	22.49	32.95	57.02	81.9	106.9	150.9	169.8
320	5.78	9.37	14.67	23.02	33.73	58.36	83.8	106.0	149.6	168.3
330	5.88	9.59	15.01	23.55	34.51	59.70	83.7	101.6	143.4	161.3
340	6.09	9.80	15.35	24.08	35.29	61.05	83.4	101.6	143.1	160.9
350	6.30	10.02	15.68	24.61	36.06	62.39	80.2	97.6	137.8	155.0
360	6.41	10.23	16.02	25.14	36.84	63.74	80.4	97.6	137.8	155.0
370	6.62	10.45	16.36	25.67	37.62	65.08	77.4	94.0	132.7	149.3
380	6.72	10.66	16.70	26.20	38.39	64.00	74.6	91.3	127.9	145.0
390	6.93	10.88	17.04	26.73	39.17	64.50	75.2	91.3	128.9	145.0
400	7.14	11.10	17.37	27.26	39.95	62.30	72.6	88.2	124.5	140.1
Torque at 100 min-1 [Nm]	256	442	691	1085	1589	2750	3949	6068	8250	10862

Notes

 Indicates power ratings are governed by thermal limitations. Please consult for effect on using cooling fans.

Power Ratings [kW] 13:1, 20:1 and 25:1 units (Double Reduction)

Output min ⁻¹	015	103	107	115	203	207	215	307	315	407	415	507	608
10	0.29	0.54	0.85	1.34	1.96	3.39	4.86	7.5	10.2	13.4	19.0	26.4	46.1
12	0.36	0.67	1.04	1.64	2.40	4.16	5.97	9.2	12.5	16.4	22.5	31.4	54.9
14	0.42	0.79	1.24	1.94	2.84	4.92	7.07	10.9	14.8	19.4	25.9	36.3	63.5
16	0.47	0.91	1.43	2.24	3.29	5.69	8.17	12.6	17.1	22.5	29.3	41.3	72.1
18	0.53	1.04	1.62	2.55	3.73	6.46	9.27	14.2	19.4	25.5	32.6	46.1	80.5
20	0.59	1.16	1.82	2.85	4.18	7.22	10.37	15.9	21.7	28.5	35.9	51.0	88.9
22	0.63	1.28	2.01	3.15	4.62	7.99	11.47	17.6	24.0	31.6	39.2	55.7	97.1
24	0.69	1.41	2.20	3.46	5.06	8.76	12.57	19.3	26.3	34.6	42.3	60.4	105.3
26	0.75	1.53	2.39	3.76	5.51	9.53	13.68	21.0	28.6	37.6	45.6	65.1	113.0
28	0.81	1.65	2.59	4.06	5.95	10.29	14.78	22.7	30.9	40.7	48.7	69.7	120.6
30	0.86	1.78	2.78	4.36	6.39	11.06	15.88	24.4	33.2	43.7	51.7	74.4	128.0
32	0.92	1.90	2.97	4.67	6.84	11.83	16.98	26.1	35.5	46.7	54.9	78.8	135.2
34	0.98	2.02	3.17	4.97	7.28	12.59	18.08	27.8	37.8	49.7	57.9	83.4	142.5
38	1.10	2.15	3.36	5.27	7.72	13.36	19.18	29.5	40.1	52.8	63.7	92.5	157.0
40	1.16	2.27	3.55	5.57	8.17	14.13	20.29	31.2	42.4	55.8	66.6	96.8	164.2
42	1.20	2.39	3.74	5.88	8.61	14.90	21.39	32.9	44.7	58.8	69.2	101.1	171.5
46	1.30	2.51	3.94	6.18	9.05	15.66	22.49	34.6	47.0	61.9	74.3	109.4	186.0
50	1.42	2.64	4.13	6.48	9.50	16.43	23.59	36.3	49.3	64.9	79.0	117.5	199.2
52	1.47	2.76	4.32	6.78	9.94	17.20	24.69	37.9	51.6	67.9	81.5	120.8	206.5
54	1.52	2.88	4.52	7.09	10.38	17.96	25.79	39.6	53.9	71.0	83.8	125.6	213.7
58	1.64	3.01	4.71	7.39	10.83	18.73	26.89	41.3	56.2	74.0	88.5	132.8	225.8
62	1.76	3.13	4.90	7.69	11.27	19.50	28.00	43.0	58.5	77.0	93.0	140.1	237.9
66	1.86	3.25	5.09	7.99	11.71	20.27	29.10	44.7	60.8	80.0	97.5	147.3	248.7
70	1.96	3.38	5.29	8.30	12.16	21.03	30.20	46.4	63.1	83.1	102.0	154.6	259.6
74	2.06	3.50	5.48	8.60	12.60	21.80	31.30	48.1	65.4	86.1	104.1	157.0	270.5
78	2.15	3.72	5.83	9.15	13.41	23.20	33.31	51.2	69.6	91.6	110.4	167.8	280.1
80	2.23	3.95	6.18	9.70	14.22	24.60	35.32	54.3	73.8	97.2	112.6	154.9	246.5
85	2.34	4.17	6.54	10.26	15.03	26.00	37.33	57.4	78.0	102.7	106.0	140.1	222.3
90	2.48	4.40	6.89	10.81	15.84	27.40	39.34	60.5	82.2	108.2	99.4	125.3	198.0
95	2.61	4.62	7.24	11.36	16.64	28.80	41.35	63.5	86.4	113.6	94.2	118.7	186.8
100	2.73	4.62	7.24	11.36	16.64	28.80	41.35	60.9	86.4	106.5	89.0	112.1	175.6
Torque at 10 min ⁻¹ [Nm]	277	519	813	1276	1870	3235	4645	7139	9706	12778	18120	25254	44051

Notes

 Indicates power ratings are governed by thermal limitations. Please consult for effect on using cooling fans.

 Indicates the limit of recommended output speed for 20:1 and 25 :1 reducers

SUMITOMO CYCLO EUROPE

H S M Drive

**H S M Drive
Dimensions**

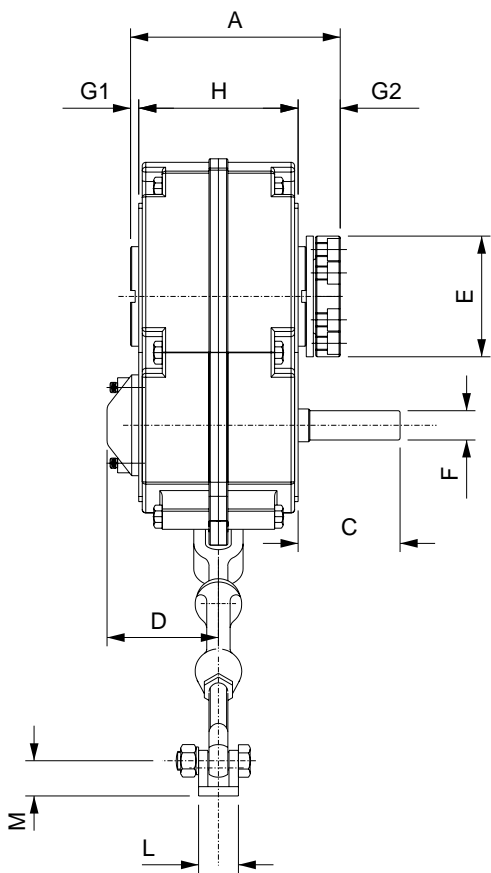
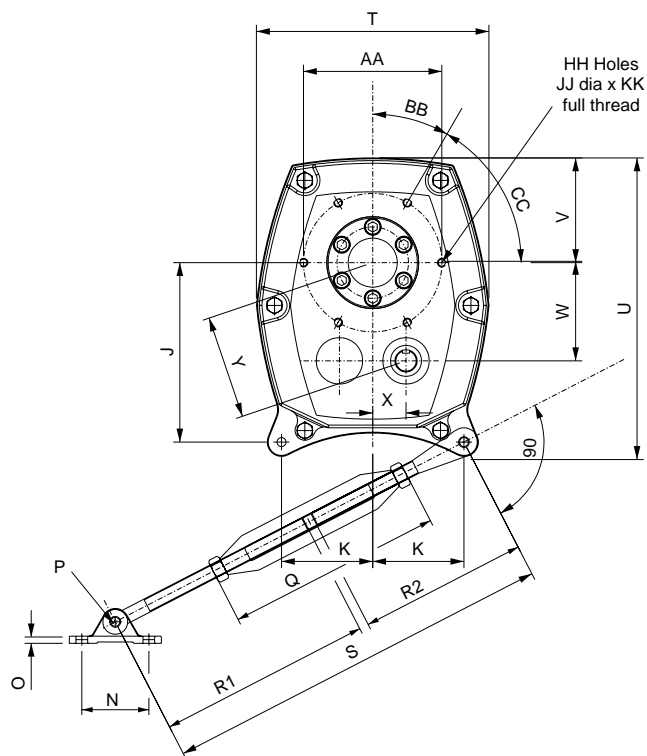

Taper-Grip® Hub

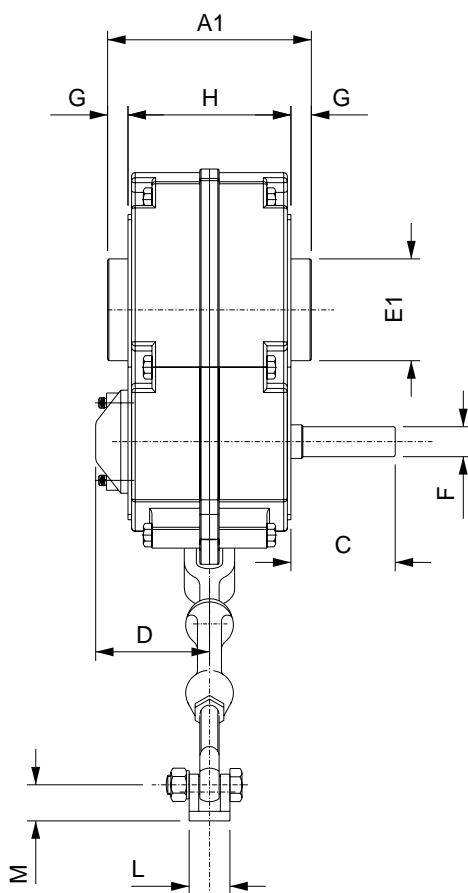

Keyed Hub

Size	015	103	107	115	203	207	215
A	138	162	170	184	201	231	261
A1	117	152	161	173	195	214	255
B	See bore size table. See page 22 & 23						
C	61	73	82	87	95	100	115
D (note 1)	65	82	93	95	108	114	127
E	74	82	92	104	114	138	152
E1	55	65	75	85	100	110	130
F	See input shaft table. See page 25.						
G	11	17	17	19	20	20	26
G1	7	7	7	7	7	7	7
G2	36	37	36	42	39	50	51
H	95	118	127	135	155	174	203
J	144	137	169	201	238	261	294
K	63	75	84	102	121	133	152
L	24	24	34	34	42	42	70
M	20	20	24	24	32	32	50
N	65	65	75	75	100	100	120
O	5	5	8	8	12	12	18
P	10	10	13	13	17	17	16
Q	200	200	216	216	216	216	222
R1	300	300	350	350	375	375	375
R2	167	167	189	189	246	246	263
S Min.	467	467	539	539	621	621	638
Max.	617	617	689	689	771	771	788
T	160	186	218	258	278	317	365
U	228	234	282	330	385	421	477
V	72	81	96	117	129	143	162
W	66	75	90	110	125	141	156
X	24	25	31	37	43	50	56
Y	70	79	95	116	133	150	166
AA	106	120	130	155	175	212	255
BB	45°	45°	45°	30°	30°	30°	0°
CC	90°	90°	90°	60°	60°	60°	60°
HH	4	4	4	6	6	6	5
JJ	M8	M10	M10	M10	M12	M16	M20
KK	5	15	15	15	18	21	25
Weight single (kg)	10	14	22	31	45	64	100
double	11	15	24	34	49	69	108

Note: 1). Dimension D is increased by 7mm when a backstop is fitted.

Nominal ratio	Size						
	015	103	107	115	203	207	215
5:1	5.091	4.941	5.300	5.047	5.047	5.047	
13:1	13.315	13.410	14.268	13.587	13.587	13.395	13.587
20:1	20.095	20.421	20.481	20.455	20.455	20.455	20.455
25:1	-	23.544	25.600	25.235	25.235	25.235	25.235

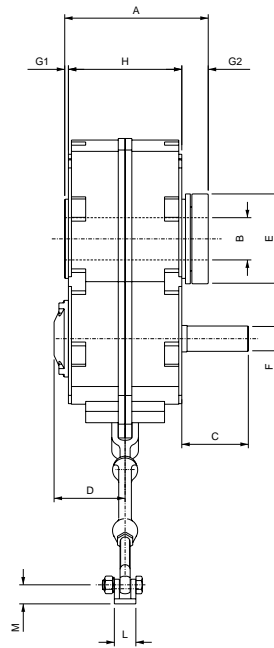
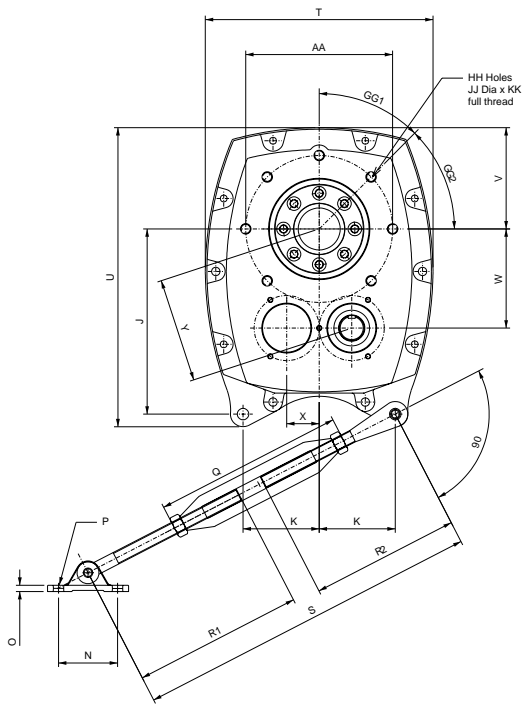

Taper-Grip® Hub

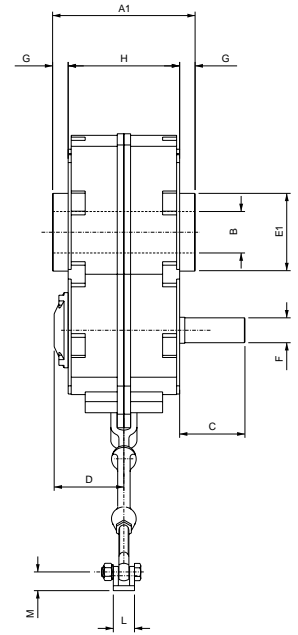

Keyed Hub

Size 307 - 407

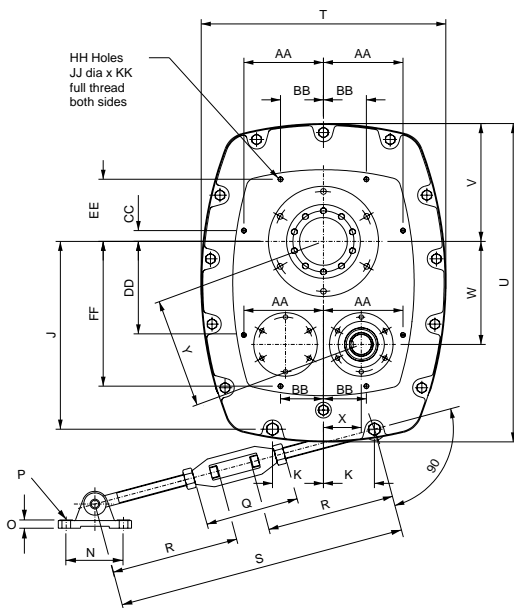

Taper-Grip® Hub

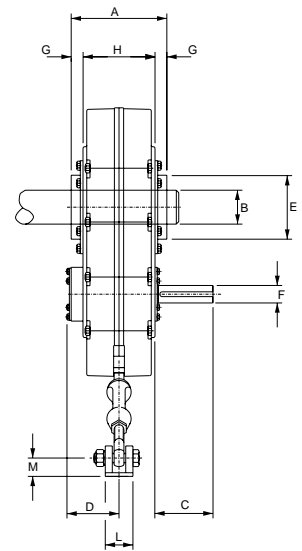

Keyed Hub

Size 415 - 608

Size	307	315	407	415	507	608
A	272	278	290	310	356	406
A1	275	290	312	297	345	395
B	See bore size table. See page 22 & 23					
C	126	145	180	186	216	241
D (Note 1)	133	134	141	196	203	225
E	170	186	207	218	238	278
E1	150	160	180	207	232	276
F	See input shaft table. See page 25					
G	30	35	44	44	44	44
G1	7	7	7	21	22	22
G2	50	51	59	54	55	55
H	215	220	224	222	268	318
J	353	456	519	513	590	677
K	145	157	160	102	160	190
L	70	70	70	70	110	110
M	50	50	50	50	76	76
N	120	120	120	120	180	180
O	18	18	18	18	26	26
P	16	16	16	M16	M24	M24
Q	222	222	222	222	265	265
R -	-	-	-	375	400	400
R1	375	375	375	-	-	-
R2	263	263	263	-	-	-
S Min.	638	638	638	750	800	800
S Max.	788	788	788	900	950	950
T	434	542	568	643	770	880
U	570	734	814	841	1000	1140
V	195	254	281	298	370	410
W	189	255	267	280	324	373
X	62	75	92	100	119	133
Y	200	266	282	297	345	396
AA	280	280	320	208	250	315
BB	-	-	-	60	135	130
CC	-	-	-	-19	34	-40
DD	-	-	-	227	294	280
EE	-	-	-	176	195	215
FF	-	-	-	404	455	535
GG1	0°	22.5°	22.5°	-	-	-
GG2	45°	45°	45°	-	-	-
HH	7	8	8	8	8	8
JJ	M20	M20	M20	M16	M16	M16
KK	24	30	24	27	27	27
Weight Single (kg)	147	201	257	-	-	-
Weight Double (kg)	155	219	282	385	545	740

Note: Dimension D is increased by 7mm when a backstop is fitted. (Sizes 307, 315 & 407)

Nominal ratio	Size					
	307	315	407	415	507	608
5:1	5.047	5.047	4.684			
13:1	13.587	13.587	13.644	13.270	13.260	12.850
20:1	20.455	20.455	20.113	19.970	19.580	19.330
25:1	25.235	25.235	23.654	24.000	24.733	22.601

Taper Grip® (mm)

Unit Size	Metric Bore Sizes Available	Hub Code	
		Deep Groove	Taper Roller
015	20, 25, 30	116AHA6000	116AHB6000
103	30, 35, 40	116BHA6000	116BHB6000
107	38, 40, 45, 50	116CHA6000	116CHB6000
115	42, 45, 48, 50, 55	116DHA6000	116DHB6000
203	50, 55, 60, 62, 65	116EHA6000	116EHB6000
207	60, 65, 70, 75	116FHA6000	116FHB6000
215	65, 70, 75, 80, 85	116GHA6000	116GHB6000
307	80, 85, 90, 95, 100	116HHA6000	116HHB6000
315	90, 100, 110, 115, 120	116JHA6000	116JHB6000
407	100, 110, 120, 125	116SHA6000	116SHB6000
415	100, 110, 120, 125	-	016K6107
507	115, 125, 130, 140, 150	-	016L6107
608	130, 150, 180,190	-	016M6107

Taper Grip® (inch)

Unit Size	Inch Bore Sizes Available
015	13/16", 1", 1 3/16"
103	1 3/16", 1/4", 1 5/16", 1 3/8", 1 1/2"
107	1 7/16", 1 1/2", 1 3/4", 1 15/16"
115	1 11/16", 1 7/8", 1 15/16", 2", 2 3/16"
203	1 15/16", 2", 2 1/8", 2 3/16", 2 1/4", 2 3/8", 2 7/16"
207	2 3/16", 2 1/4", 2 7/16", 1 1/2", 2 11/16", 2 3/4", 2 15/16", 3"
215	2 7/16", 2 1/2", 2 11/16", 2 7/8", 2 15/16", 3", 3 7/16"
307	2 15/16", 3", 3 3/16", 3 7/16", 3 1/2", 3 15/16"
315	3 7/16", 3 15/16", 4 7/16", 4 1/2"
407	3 15/16", 4 7/16", 4 1/2", 4 15/16"
415	3 15/16", 4 7/16", 4 1/2", 4 15/16"
507	4 7/16", 4 15/16", 5", 5 3/16", 5 7/16", 5 1/2", 5 15/16"
608	4 15/16", 5", 5 1/2", 5 15/16", 6", 6 7/16", 6 1/2", 7", 7 1/2"

Notes: Taper Grip tolerances up to h11 can be accommodated.
Hub codes relate to the output hub spare part number (see pages 47 & 49)

Other bores available on special order.

Output Bores (mm)

Unit Size	Standard Metric Bores					
	Bore	Hub Code	Bore	Hub Code	Bore	Hub Code
015	30	116AHC6030	-	-	40	116AHC6040
103	30	116BHC6030	40	116BHC6040	50	116BHC6050
107	40	116CHC6040	50	116CHC6050	55	116CHC6055
115	50	116DHC6050	55	116DHC6055	65	116DHC6065
203	55	116EHC6055	65	116EHC6065	75	116EHC6075
207	65	116FHC6065	75	116FHC6075	85	116FHC6085
215	75	116GHC6075	85	116GHC6085	100	116GHC6100
307	85	116HHC6085	100	116HHC6100	120	116HHC6120
315	100	116JHC6100	120	116JHC6120	125	116JHC6125
407	120	116SHC6120	125	116SHC6125	135	116SHC6135
415	125	016K6105				
507	150	016L6105				
608	190	016LM6105				

Notes: Metric hubs are bored to F7 limits.

Hub codes relate to the output hub spare part number (see pages 47 & 49) for use with deep groove

Output Bores (inch)

Unit Size	Standard Inch Bores					
	Bore	Hub Code	Bore	Hub Code	Bore	Hub Code
015	15/16"	116AHF6015				
103	1 3/16"	116BHF6103	1 7/16"	116BHF6107	1 15/16"	116BHF6115
107	1 7/16"	116CHF6107	1 15/16"	116CHF6115	2 3/16"	116CHF6203
115	1 15/16"	116DHF6115	2 3/16"	116DHF6203	2 7/16"	116DHF6207
203	2 3/16"	116EHF6203	2 7/16"	116EHF6207	2 15/16"	116EHF6215
207	2 7/16"	116FHF6207	2 15/16"	116FHF6215	3 7/16"	116FHF6307
215	2 15/16"	116GHF6215	3 7/16"	116GHF6307	3 15/16"	116GHF6315
307	3 7/16"	116HHF6307	3 15/16"	116HHF6315	4 7/16"	116HHF6407
315	3 15/16"	116JHF6315	4 7/16"	116JHF6407	4 15/16"	116JHF6415
407	4 7/16"	116SHF6407	4 15/16"	116SHF6415		
415	4 15/16"	016K6116				
507	5 7/16"	016L6116				
608	6 1/2"	016M6116				

Notes: Hub codes relate to the output hub spare part number (see pages 47 & 49) for use with taper roller

bearings. Other bore types can be achieved by using reducing bushes (see page 24) Inch hubs are bored to h7 limits. A shaft tolerance of h7 is recommended.

Hub Keyways (mm)

Shaft Diameter (mm)	Key Size	
	U1	U2
30	8	7
40	12	8
50	14	9
55	16	10
65	18	11
75	20	12
85	22	14
100	28	16
120	32	18
125	32	18
135	36	20
150	36	20
190	45	25

Keyways for standard output hubs are machined in accordance with BS425 for metric shafts

Hub Keyways (inch)

Shaft Diameter (inch)	Key Size	
	U1	U2
1 15/16"	1/4"	1/4"
1 3/16"	1/4"	1/4"
1 7/16"	3/8"	3/8"
1 15/16"	1/2"	1/2"
2 3/16"	1/2"	1/2"
2 7/16"	5/8"	5/8"
2 15/16"	3/4"	3/4"
3 7/16"	7/8"	7/8"
3 15/16"	1"	1"
4 7/16"	1"	1"
4 15/16"	1 1/4"	1 1/4"
5 7/16"	1 1/4"	1 1/4"
6 1/2"	1 1/2"	1 1/2"

Keyways for the output hubs are machined in accordance with ANSI B17.1 - 1967

Reducing Bushes (mm)

Unit Size	Metric reducing bushes					
	Standard bore	Reducing bush bores	Standard bore	Reducing bush bores	Standard bore	Reducing bush bores
015	30	20, 25	-	-	40	32, 35
103	30	20, 25	40	32, 35	50	38, 42, 45
107	40	30, 32, 35	50	38, 42, 45	55	42, 45
115	50	38, 40, 42, 45	55	42, 45	65	60
203	55	42, 45, 50	65	50, 60	75	60, 70
207	65	50, 55, 60	75	60, 70	85	70, 80
215	75	60, 65, 70	85	70, 80	100	90, 95
307	85	70, 75, 80	100	90, 95	120	90, 110
315	100	90, 95	120	90, 110	125	90, 110
407	120	90, 100, 110	125	90, 100, 110	135	-
415	125	90, 100, 110	-	-	-	-
507	150	100, 125, 130	-	-	-	-
608	190	-	-	-	-	-

Reducing Bushes (inch)

Unit Size	Inch reducing bushes (BS46 keyways only)					
	Standard bore	Reducing bush bores	Standard bore	Reducing bush bores	Standard bore	Reducing bush bores
015	30	3/4", 1"	-	-	40	1 1/4"
103	30	3/4", 1"	40	1 1/4"	50	1 1/2", 1 3/4"
107	40	1 1/4"	50	1 1/4", 1 1/2", 1 3/4"	55	1 1/2", 1 3/4", 2"
115	50	1 1/4", 1 1/2", 1 3/4"	55	1 1/2", 1 3/4", 2"	65	2", 2 1/4"
203	55	1 1/2", 1 3/4", 2"	65	2", 2 1/4"	75	2 1/4", 2 1/2", 2 3/4"
207	65	2", 2 1/4"	75	2 1/4", 2 1/2", 2 3/4"	85	2 1/2", 2 3/4", 3"
215	75	2 1/4", 2 1/2", 2 3/4"	85	2 1/2", 2 3/4", 3"	100	3 1/2"
307	85	2 1/2", 2 3/4", 3"	100	3 1/2"	120	3 1/2", 4", 4 1/2"
315	100	3 1/2"	120	3 1/2", 4", 4 1/2"	125	3 1/2", 4", 4 1/2"
407	120	3 1/2", 4", 4 1/2"	125	3 1/2", 4", 4 1/2"	135	-
415	125	3 1/2", 4", 4 1/2"	-	-	-	-
507	150	4 1/2", 5", 5 1/2"	-	-	-	-
608	190	-	-	-	-	-

Reducing Bushing Keyways (inch)

Shaft Diameter (inch)	Key Size		Shaft Diameter (inch)	Key Size		Shaft Diameter (inch)	Key Size	
	U1	U2		U1	U2		U1	U2
3/4"	3/16"	3/16"	2"	1/2"	5/16"	3 1/2"	7/8"	5/8"
1"	1/4"	1/4"	2 1/4"	5/8"	7/16"	4"	1"	3/4"
1 1/4"	5/16"	1/4"	2 1/2"	5/8"	7/16"	4 1/2"	1 1/4"	7/8"
1 1/2"	3/8"	1/4"	2 3/4"	3/4"	1/2"	5"	1 1/4"	7/8"
1 3/4"	7/16"	5/16"	3"	3/4"	1/2"	5 1/2"	1 1/2"	1"

Keyways for reducing bushes are machined in accordance with BS46
 Keys are supplied with reducing bushes, but not where the output hub directly fits the shaft.

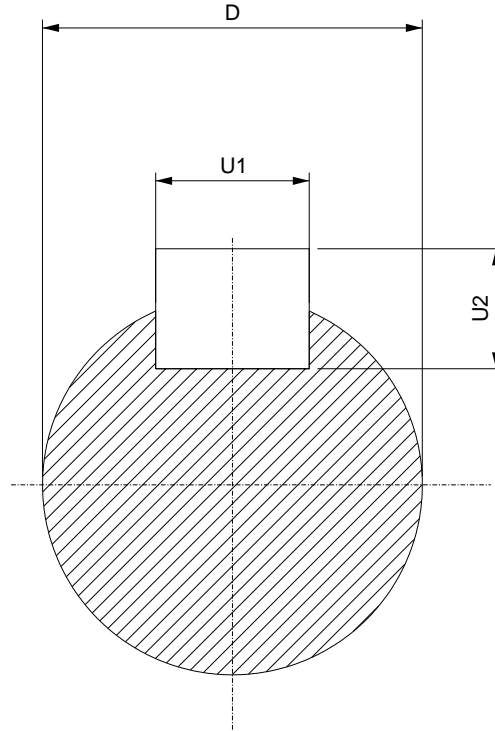

Input Shaft Dimensions (mm)

Unit Size	Shaft Diameter D (mm)	Key Size	
		U1	U2
015	19	6	6
103	19	6	6
107	22	6	6
115	25	8	7
203	28	8	7
207	32	10	8
215	42	12	8

Unit Size	Shaft Diameter D (mm)	Key Size	
		U1	U2
307	48	14	9
315	55	16	10
407	60	18	11
415	60	18	11
507	65	18	11
608	85	22	14

Input Shaft Dimensions (inch)

Keyways for the output hubs are machined in accordance with ANSI B17.1 - 1967

Unit Size	Shaft Diameter D (inch)	Key Size	
		U1	U2
015	3/4"	3/16"	3/16"
103	3/4"	3/16"	3/16"
107	15/16"	1/4"	1/4"
115	1 1/16"	1/4"	1/4"
203	1 1/8"	1/4"	1/4"
207	1 5/16"	5/16"	5/16"
215	1 11/16"	3/8"	3/8"

Unit Size	Shaft Diameter D (inch)	Key Size	
		U1	U2
307	1 7/8"	1/2"	1/2"
315	2 3/16"	1/2"	1/2"
407	2 7/16"	5/8"	5/8"
415	2 7/16"	5/8"	5/8"
507	2 9/16"	5/8"	5/8"
608	3 3/8"	7/8"	7/8"

To calculate the allowable overhung load on the input shaft at any position, first establish the maximum load at the mid shaft position for the unit size and input speed required (Table 1). Divide this load by the factor from Table 2 corresponding to the actual position of the load along the input shaft

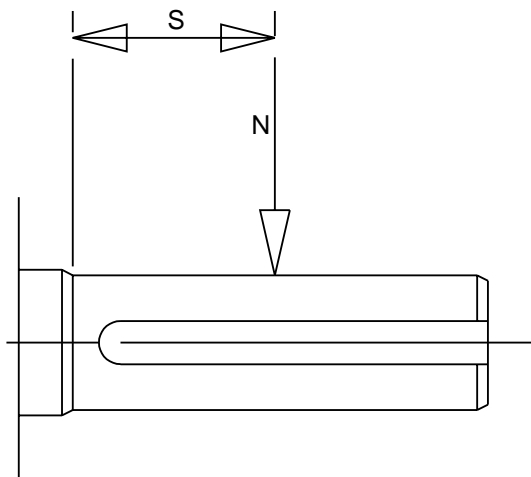

Table 1

Unit Size	Input Speed 'rpm'				
	2000	1500	1000	750	500
Radial Load at Shaft Centre - 'N' in Newtons					
015	575	640	755	840	980
103	1140	1275	1480	1645	1900
107	1305	1460	1700	1890	2185
115	1730	1935	2260	2515	2915
203	3300	3675	4265	4730	5455
207	3990	4445	5160	5725	6605
215	6775	7525	8695	9615	11055
307	7110	7970	9315	10375	12030
315	9710	10815	12550	13915	16045
407	10445	11610	13430	14865	17110

Table 2

Unit Size	Distance from Shaft Shoulder 'S' in 'mm'																								
	5	10	15	20	25	30	35	40	45	50	55	60	70	80	90	100	110	120	130	140	150	160	170		
Factor																									
015	0.80	0.83	0.86	0.90	0.93	0.97	1.00	1.04	1.07	1.12	1.15	1.19													
103	0.85	0.88	0.90	0.93	0.95	0.97	1.00	1.02	1.05	1.08	1.10	1.12													
107	0.85	0.87	0.89	0.91	0.93	0.95	0.98	1.00	1.02	1.04	1.07	1.09	1.13												
115	0.88	0.90	0.91	0.93	0.95	0.96	0.98	1.00	1.02	1.04	1.06	1.07	1.11												
203	0.84	0.86	0.88	0.90	0.92	0.94	0.96	0.98	1.00	1.02	1.04	1.06	1.11	1.15											
207	0.85	0.86	0.88	0.90	0.91	0.93	0.95	0.97	0.98	1.00	1.02	1.04	1.07	1.11	1.14										
215	0.84	0.86	0.87	0.89	0.90	0.92	0.94	0.95	0.97	0.98	1.00	1.02	1.05	1.08	1.12	1.15									
307	0.87	0.88	0.89	0.90	0.91	0.92	0.94	0.95	0.96	0.97	0.99	1.00	1.03	1.05	1.08	1.11	1.13								
315	0.83	0.84	0.85	0.87	0.88	0.89	0.91	0.92	0.93	0.95	0.96	0.97	1.00	1.03	1.06	1.08	1.11	1.14	1.17						
407	0.79	0.80	0.82	0.83	0.84	0.85	0.86	0.88	0.89	0.90	0.91	0.92	0.95	0.97	1.00	1.03	1.05	1.08	1.10	1.13	1.15	1.18	1.21		

GENERAL OPTIONS

Motor Mounts.....	28
Screw Conveyor.....	30
Motorised Options.....	32
Backstop.....	33
Harsh Environment Sealing..	33
Warranty.....	34
Technical Service.....	34
Signature Service.....	34
Other Sumitomo Options.....	35

**H S M Drive
Options**

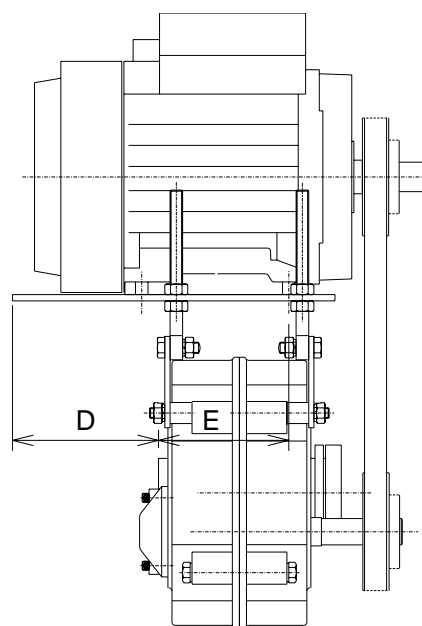
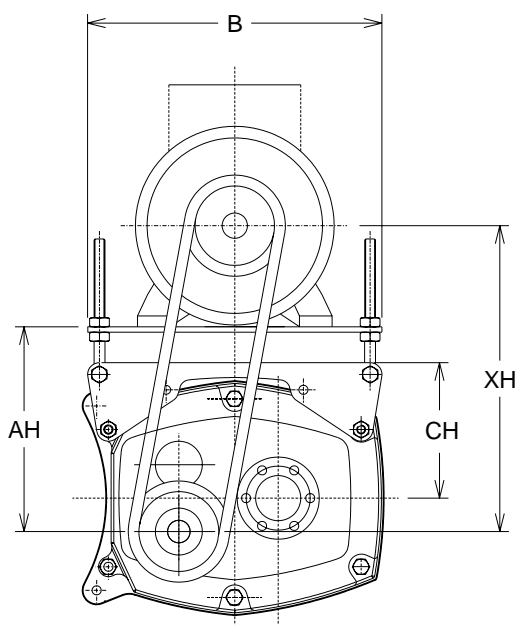
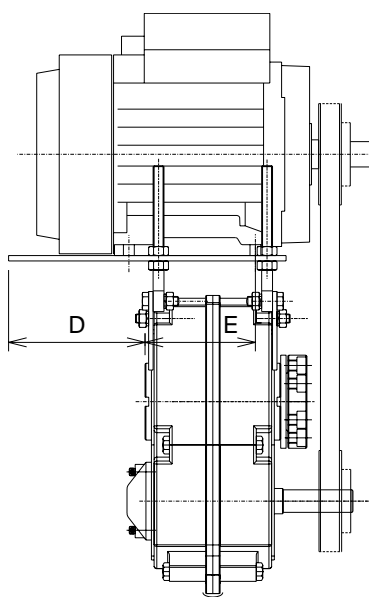
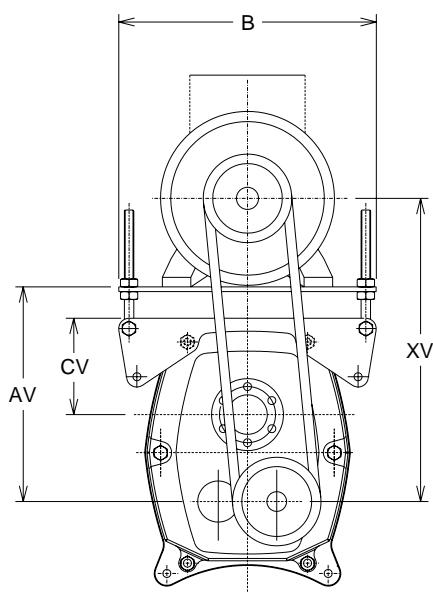

To avoid the design and manufacture of a separate support for the motor when using a belt drive, a rigid support for the driving motor is available.

The motor mounts have been designed to fit onto any side of the HSM gearbox.

This permits the use of various belt centre distances, easy belt tensioning and avoids alignment problems.

The motor mounts are available to accommodate a wide range of motor frame sizes and types, including IEC and NEMA.

A drilling template is provided to indicate the size and position of the holes required to suit the motor selected.

Unit Size	AV		AH		B	CV	CH	D
	Min.	Max.	Min.	Max.				
103	237	413	198	375	289	87	98	48
107	264	440	225	402	325	102	122	68
115	302	479	259	433	325	122	149	63
203	348	518	286	454	375	144	164	43
207	367	537	305	475	418	149	179	88
215	403	621	333	548	479	175	200	175
307	473	687	378	594	479	208	241	196
315	637	840	494	695	541	276	313	210
407	694	897	525	729	556	325	332	237

Dimension E for each motor frame size

Unit Size	IEC Motor Frame										
	63	71	80	90	100	112	132	160	180	200	225
103	128	123	108	92	-	-	-	-	-	-	-
107	144.5	139.5	124.5	108.5	91.5	-	-	-	-	-	-
115	-	153	138	122	105	98	-	-	-	-	-
203	-	-	165.5	149.5	132.5	125.5	-	-	-	-	-
207	-	-	191	174	158	151	112	-	-	-	-
215	-	-	-	215.5	198.5	191.5	152.5	103.5	-	-	-
307	-	-	-	234.5	217.5	210.5	171.5	122.5	109.5	-	-
315	-	-	-	-	241	234	195	146	133	122	-
407	-	-	-	-	-	-	234	185	172	160	114

Note: Dimension E is measured from front motor mounting bolt to output hub face this information allows the user to calculate the position of the motor cowl

To determine the optimum belt length when using a motor mount, first calculate the centre distances as follows:

$$\begin{aligned} \text{XV/XH min} &= \text{Motor Frame Size} + \text{'AV/AH min'} \\ \text{XV/XH max} &= \text{Motor Frame Size} + \text{'AV/AH max'} \end{aligned}$$

A belt length should be selected which gives a centre distance equal to or slightly larger than the 'XV/XH min' and smaller than the 'XV/XH max' values determined above.

The screw conveyor adapter allows the use of a standard HSM gearbox to fit directly onto the trough end of a screw conveyor.

The screw conveyor adapter has been designed to the CEMA (Conveyor Equipment Manufacturers Association) standards.

The cast iron four bolt mounting adapter is fitted with double lip seals as standard.

For abrasive environments, the design allows for the use with a packing gland seal. This can be adjusted as the seal wears, and makes for easy removal and replacement without trough or the gearbox being removed.

The HSM is fitted with taper roller bearings when used with this adapter to take the thrust load from the screw conveyor, and

this eliminates the need for an external thrust bearing.

The adapter may be used in any position, including horizontal, inclined and vertical with the movement of the appropriate breathers and filler plugs on the HSM gearbox.

The drive shafts are made from high alloy steel, three bolt drilled and the taper ensures a simple installation.

Other options such as stainless steel are available upon request.

Often the unit will be used with a motor mount but, in the event that belts are not used, the HSM can be supplied with a directly driven input shaft, such as the IEC adapter.

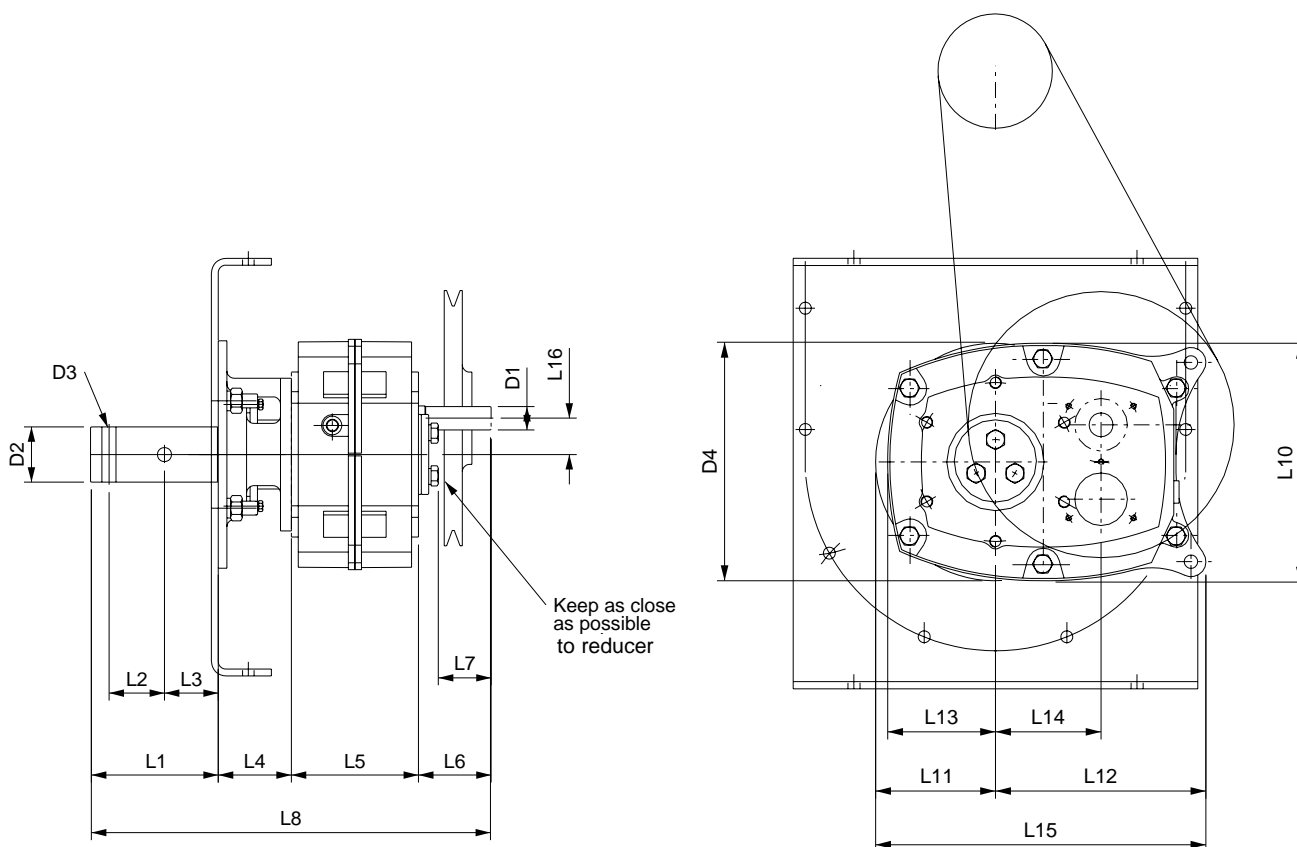

	107				115				203			
Shaft Diameter D2	1 1/2"	2"	2 7/16"	3"	1 1/2"	2"	2 7/16"	3"	1 1/2"	2"	2 7/16"	3"
Screw Diameter	6-9"	9-12"	12-14"	12-20"	6-9"	9-12"	12-14"	12-20"	9"	12-14"	12-14"	12-20"
D1	22	22	22	22	25	25	25	25	28	28	28	28
D3	13	16	16	19.5	13	16	16	19.5	13	16	16	19.5
D4	178	290	290	290	178	290	290	290	290	290	290	290
L1	152.5	152.5	170	174.6	152.5	152.5	170	174.6	152.5	152.5	170	174.6
L2	76.2	76.2	76.2	76.2	76.2	76.2	76.2	76.2	76.2	76.2	76.2	76.2
L3	54	54	70	73	54	54	70	73	54	54	70	73
L4	81.7	81.7	81.7	81.7	90.5	90.5	90.5	90.5	93.6	93.6	93.6	93.6
L5	127	127	127	127	135	135	135	135	155	155	155	155
L6	82	82	82	82	87	87	87	87	95	95	95	95
L7	63	63	63	63	66	66	66	66	74	74	74	74
L8	443.2	443.2	460.7	465.3	465	465	482.5	487	496	496	513.6	518.2
L10	218	218	218	218	258	258	258	258	278	278	278	278
L11	89	145	145	145	89	145	145	145	145	145	145	145
L12	185	185	185	185	216	216	216	216	258	258	258	258
L13	96	96	96	96	117	117	117	117	129	129	129	129
L14	90	90	90	90	110	110	110	110	125	125	125	125
L15	274	330	330	330	305	361	361	361	403	403	403	403
L16	31	31	31	31	37	37	37	37	43	43	43	43

	207					215				307			315		
Shaft Diameter D2	1 1/2"	2"	2 7/16"	3"	3 7/16"	2"	2 7/16"	3"	3 7/16"	2 7/16"	3"	3 7/16"	2 7/16"	3"	3 7/16"
Screw Diameter	9"	9-12"	12-14"	12-20"	18"-24"	9-12"	12"-14"	12"-20"	18"-24"	12-14"	12-20"	18-24"	12-14"	12-20"	18-24"
D1	32	32	32	32	32	42	42	42	42	48	48	48	55	55	55
D3	13	16	16	19.5	22.6	16	16	19.5	22.6	16	19.5	22.6	16	19.5	22.6
D4	290	290	290	290	290	290	290	290	290	290	290	290	290	290	290
L1	152.5	152.5	170	174.6	231.8	152.5	170	174.6	231.8	170	174.6	231.8	170	174.6	231.8
L2	76.2	76.2	76.2	76.2	101.6	76.2	76.2	76.2	101.6	76.2	76.2	101.6	76.2	76.2	101.6
L3	54	54	70	73	98.4	54	70	73	98.4	70	73	98.4	70	73	98.4
L4	101.6	101.6	101.6	101.6	101.6	108	108	108	108	139.5	139.5	139.5	160.3	160.3	160.3
L5	174	174	174	174	174	203	203	203	203	214	214	214	220	220	220
L6	100	100	100	100	100	115	115	115	115	126	126	126	145	145	145
L7	74	74	74	74	74	89	89	89	89	95	95	95	114	114	114
L8	528	528	545.6	550.2	607.4	578.5	596	600.6	657.8	649.5	654.1	711.3	695.3	700	757
L10	317	317	317	317	317	365	365	365	365	434	434	434	542	542	542
L11	145	145	145	145	145	145	145	145	145	145	145	145	145	145	145
L12	281	281	281	281	281	318	318	318	318	377	377	377	484	484	484
L13	143	143	143	143	143	162	162	162	162	195	195	195	254	254	254
L14	141	141	141	141	141	156	156	156	156	189	189	189	255	255	255
L15	426	426	426	426	426	463	463	463	463	522	522	522	629	629	629
L16	50	50	50	50	50	56	56	56	56	62	62	62	75	75	75

Hydraulic Options

As well as using belt drives on the input shaft, the HSM can be hydraulically driven.

The HSM can be provided with an adapter flange to SAE standards to allow hydraulic motors to be attached to the input of the gearbox.

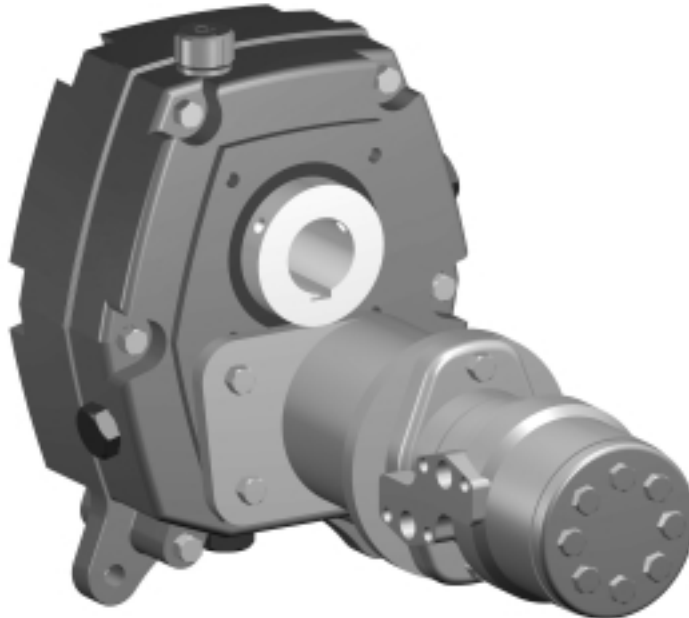

Motorised Input Units

Like the hydraulic motor configuration, the HSM can be supplied with IEC or Nema flange adapters to fit motors directly to the gearbox.

This allows the HSM to be used as a geared motor, and avoids the use of belts, pulleys or input guards.

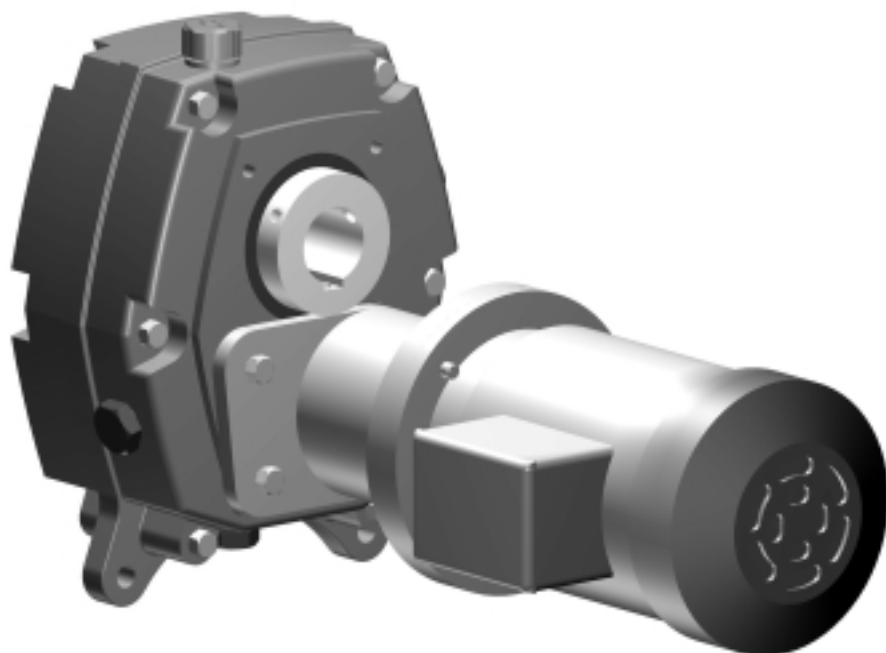

SUMITOMO CYCLO EUROPE

H S M Drive

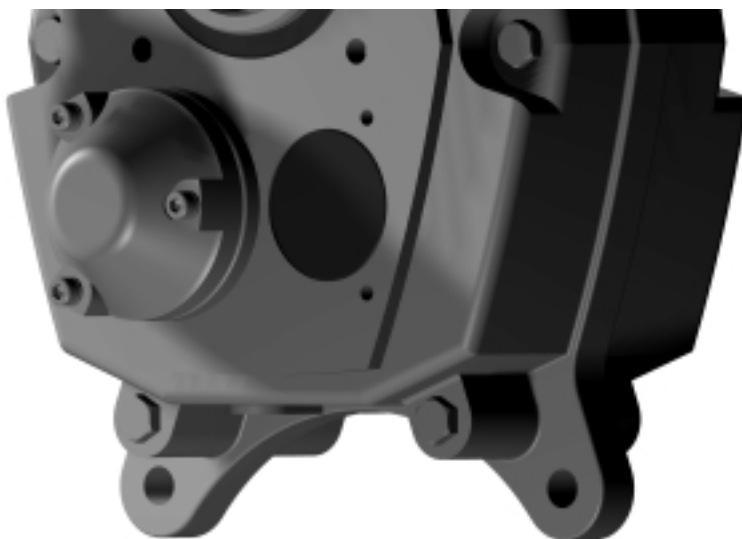

Backstop

The HSM can be fitted with a mechanical backstop to prevent reverse rotation.

The backstop is internally mounted on the input shaft. It is supplied separately so the correct rotation can be observed at the application. It is quickly and easily fitted and can be retrofitted to any unit. No additional lubrication is necessary, as it uses the gearbox oil.

Harsh Environment sealing

For added protection against dust, dirt and moisture, the HSM can be fitted with taconite seals for harsh environments (please advise when ordering)

The unit can also be fitted with increased ingress protected breathers, for example, as used in the cement industry.



SUMITOMO CYCLO EUROPE

H S M Drive

Warranty

Standard warranty is two years from date of despatch from the factory.

Service

Full application and technical support service is available for the range of products covered by this catalogue.

For details please contact your nearest Sumitomo sales office address at the rear of this catalogue. Look at <http://www.sumitomo-cyclo.com>, or alternatively e-mail:

marketing@sumitomo-cyclo.com

Full application and technical support service is available for the range of products covered by this catalogue.

Signature Service

Extended warranties are available to all our customers who purchase gearboxes already supplied with lubricant for their application.

This service reinforces Sumitomo's partnership with our customers, to extend the life of the product by condition monitoring techniques and service visits.

Sumitomo's 'Signature Service' partnership can be tailored to meet customer requirements.

**SUMITOMO
CYCLO EUROPE**



Mobil

SUMITOMO CYCLO EUROPE

H S M Drive

Other Sumitomo drive solutions

For high ratios or lower output speeds, and other design drive solutions Sumitomo have a range of alternative products such as:

Helical Buddy Box (HBB)

An integral item within Sumitomo's unique Cyclo range of gearmotors, the HBB is a Cyclo driven HSM reducer incorporating the distinctive benefit of 500% shock overload.

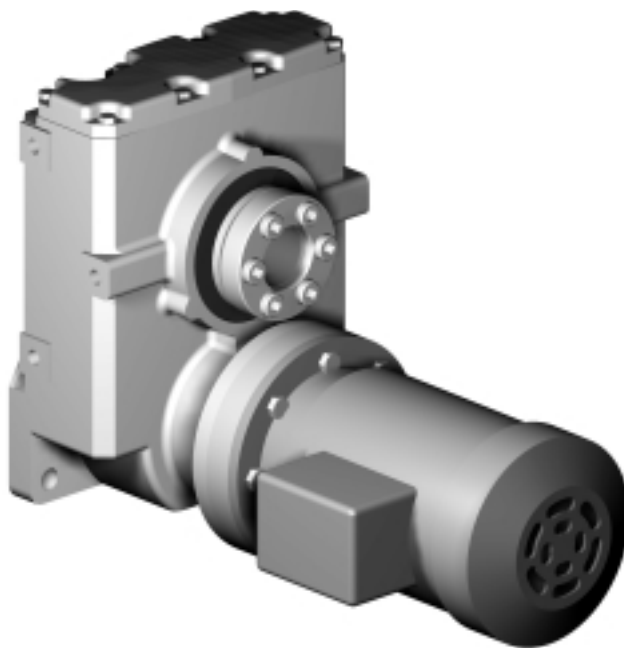

Paramax

Incorporating monoblock and split case designs available in a range of 24 sizes, the Paramax range offers greater options and torque capacity increases to 560,000 Nm.

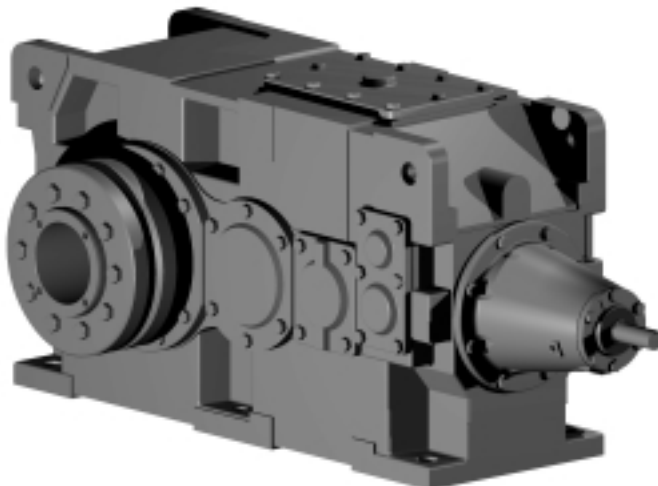

SUMITOMO CYCLO EUROPE

H S M Drive

SUMITOMO CYCLO EUROPE

H S M Drive

H S M Drive Installation

IMPORTANT - For Taper-Grip[®] installation see page 40.

Study these instructions carefully before installing and operating the drive. Make sure that this information is readily available to all persons involved in the operation and maintenance of the drive. All appropriate safety regulations must be observed when installing a drive. Suitable safety covers or guarding must be provided for all rotating shafts. The drive is designed exclusively for use as specified in the catalogue, any other use is considered improper. The manufacturer accepts no liability for damage as a result thereof.

Before switching on or starting up the machine, make sure that nobody can be endangered by the machine/system startup. Own modifications and/or alterations which affect the safety of the drive are not permitted. Spare parts (see page 46) must comply with the technical requirements specified by SUMITOMO CYCLO DRIVE EUROPE. This is always ensured with original spare parts.

1. Ensure that the shaft onto which the reducer is to be mounted and the reducer bore are clean and free from burrs. Liberally smear the shaft and reducer bore with the contents of the tube which accompanies the reducer. This acts as a lubricant to aid mounting and facilitates easy removal by prevention of fretting and atmospheric corrosion. If the box is to be used with a bushed bore the bushes should now be fitted. Two bushes are supplied, one plain and one split.

The plain bush should always be positioned at the side opposite the input shaft. The split or keyway in the remaining bush must align with the hub keyway.

The bushes can be held in position by inserting the screws found at 120° to the keyway into the bush, care should be taken not to have the screws protruding through the bush. The screws should be fitted as indicated on the leaflet supplied with the bushes.

2. Slide the reducer onto the driven shaft which must pass through the full width. A key is supplied with the split bush, this should now be fitted. A keywayed bush should be fitted with standard section side fitting keys. Do not use taper or top fitting keys. Tighten all four screws onto the driven shaft.

3. Install pulley on input shaft as close to the reducer as possible. See fig. 1.

4. Install motor and V-Belt drive with the belt pull at approximately 90° to the centre line between driven and input shafts. See fig. 2. This will permit tensioning of the V-Belt drive with the torque-arm, which should preferably be in tension.

5. Install torque-arm on reducer by placing the forked rod end over the suitable torque-arm case bolt hole and inserting the bolt supplied. Tighten the nut/bolt to the torque stated on page 39.

6. Install torque-arm fulcrum on a rigid support so that the torque-arm will be at approximately right angles to the centre line through the driven shaft and the torque-arm case bolt. See fig. 3. Make sure there is sufficient take up in the turnbuckle for belt tension adjustment.

7. Fill with suitable lubricant as detailed on page 41.

Keep close **Figure 1**

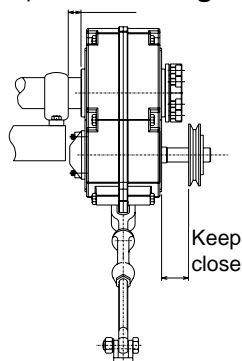

Figure 2

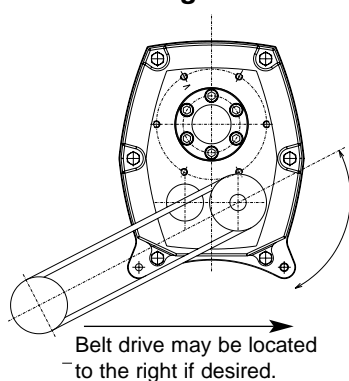
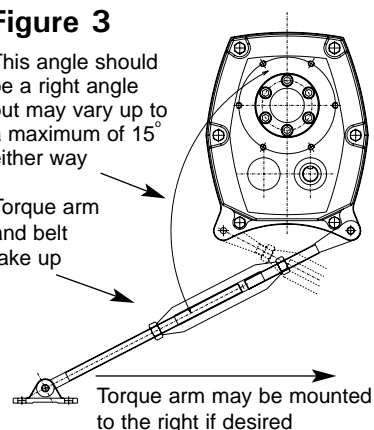

Figure 3

This angle should be a right angle but may vary up to a maximum of 15° either way

Torque arm and belt take up



N.B. Backstops: A backstop for mounting inside the reducer to prevent reversal of direction is available for all reducers. For installation instructions see page 42.

SUMITOMO CYCLO EUROPE

H S M Drive

REMOVING PARALLEL BORE REDUCER FROM SHAFT

Loosen screws in output hub. Using any suitable three or four point hub drawer, engage suitable extractor studs in the tapped case holes around the output hub and remove the gearbox by screwing down on the shaft.

IMPORTANT

Using tools normally found in a maintenance department, the reducer can be dismantled and re-assembled. Cleanliness is very important to prevent the introduction of dirt into the bearings and other parts of the reducer. A tank of clean solvent, an arbor press and equipment for heating bearings and gears should be available for shrinking these parts on the shafts.

Rubbing type oilseals are fitted and great care should be taken during dismantling and re-assembling to avoid damage to the rubbing surfaces.

The keyseat in the input shaft and the six holes in the output hub should be covered with tape or other suitable material. Any burrs on shaft or hub surfaces should be carefully removed before fitting seals.

We are prepared to repair reducers for customers who do not have proper facilities or who do, for any reason, desire factory service.

An estimate for the cost will be sent after examination and before the repair is begun.

ORDERING PARTS

When ordering parts for a reducer specify Reducer Size, Serial No., part name, code number and quantity required. It is strongly recommended that when a pinion or gear is replaced the mating gear or pinion be replaced also.

If the large gear on the output hub must be replaced, it is recommended that an output hub assembly of a gear assembled on a hub be ordered to secure undamaged surfaces on the outer hub where the oilseals rub. However, if it is desired to use the old output hub, press the gear and bearing off and examine the rubbing surfaces under the oilseal carefully for possible scratching or other damage resulting from the pressing operation.

To prevent oil leakage at the shaft oilseals, the smooth surface of the output hub must not be damaged. If any parts must be pressed from a shaft or from the output hub, this should be done before ordering parts to make sure that none of the bearings or other parts are damaged on removal.

Do not press against the outer race of any bearing. Because old shaft oilseals and gaskets may be damaged in dismantling, it is advisable to order replacements for these parts.

Torque arm tightening torques

HSM Size	015 to 103	107 to 115	203 to 407	415	507	608
Torque (Nm)	20	30	80	277	480	950

NOTE: Satisfactory performance depends on proper installation. Therefore all instructions must be carefully followed.

FITTING THE REDUCER TO THE SHAFT

1. Check the size and condition of the shaft to which the reducer will be fitted. Maximum tolerance is h11 although this should be improved upon where possible. Ensure the shaft and Taper-Grip® bush bore are free from burrs and corrosion. Clean both bore and shaft with solvent to remove all traces of grease and oil.

2. Lightly oil the screws and insert into the Taper-Grip® bush ensuring they do not project beyond the rear face.

3. Fit the thrust collar onto the Taper-Grip® bush, ensuring it is located on the spigot immediately behind the flange. Screw the Taper-Grip® bush into the hub in a clockwise direction until the thrust collar is trapped between the flange and the reducer hub.

4. Unscrew the bush until a gap of approx. 1mm is seen between the flange and the thrust collar (see diagram). Tighten all screws until they are finger tight. On reducers with a keyslot on the end of the hub, ensure that a screw is **NOT** positioned over the keyslot.

5. Slide the reducer onto the shaft at least as far as the counter bore, if present, in the Taper-Grip® bush.

Gradually tighten each screw in turn to the torque levels shown in Table 1. If the shaft has passed through the counter bore, grease fill the cavity at the shaft end to prevent the build up of corrosion. Continue installation from step 3 on page 38.

6. After the reducer has been running for 20 or 30 hours re-torque the screws to the values in Table 1. Screw torques should be subsequently checked at normal service intervals (i.e. every 6 months).

REMOVING THE REDUCER FROM THE SHAFT

Slacken each screw gradually until they are free from the thrust collar.

Give the Taper-Grip® bush a sharp tap with a mallet to break the taper, this will free the reducer. Finger tighten two of the screws against the thrust collar to prevent the Taper-Grip® bush locking in the opposite direction as the reducer is removed from the shaft.

If, as a result of shaft corrosion, the bush is difficult to move, any loose corrosion must first be removed. The reducer can then be withdrawn with the aid of a suitable hub drawer attached to the threaded holes on the Taper-Grip® Bush flange.

Table 1.

HSM Size	Screw size Qty. & Code		Thrust Collar Code	Screw Torque (max) ¹	
	Nm	lb ft			
015	6xM10	112B7003	112B6146	40	30
103	6xM10	112B7003	112C6146	50	37
107	6xM10	112B7003	112D6146	55	41
115	6xM12	112E7003	112E6146	75	56
203	6xM12	112E7003	112F6146	140	104
207	6xM16	112G7003	112G6146	250	185
215	6xM16	112G7003	112H6146	300	223
307	8xM16	112G7003	112J6146	300	223
315	10xM16	112G7003	112S6146	300	223
407	12xM16	112S7003	112K6146	250	185
415	12xM16	112S7003	112K6146	250	185
507	15xM16	112S7003	112L6146	250	185
608	20xM16	112S7003	112M6146	250	185

1. Screw torque can be reduced if required output torque is below catalogue rating

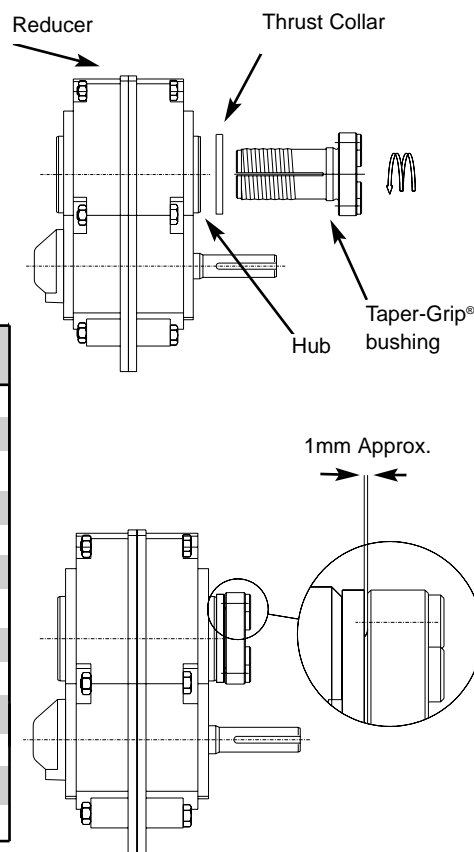

IMPORTANT

The reducer is despatched without oil. It must be filled as instructed before running. Use high grade oil as stated below. Fill to level plug when reducer is not running. The approximate quantities are shown in table below. Drain, flush and refill every six months of operation, check oil level regularly. Positions of filler, breather and drain plug for different mounting positions are shown in fig. 4.

CAUTION

Too much oil will cause over-heating. Too little oil will cause gear failure.

Health and Safety at Work Act 1974
Attention is drawn to the "Codes of Practice" issued by oil companies in respect of the handling of their products.

figure 4

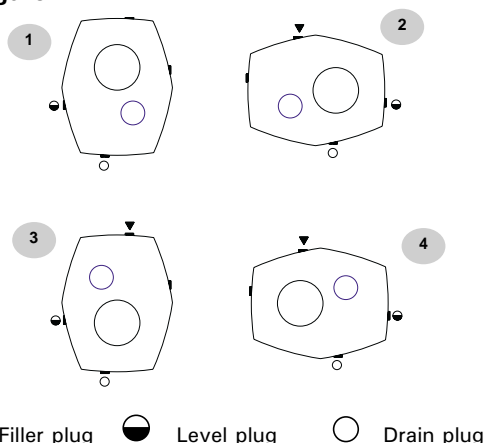

▼ Filler plug ● Level plug ○ Drain plug

Units are fitted with filler, level and drain plugs generally in position shown.

Approximate oil quantities (litres) Required for different mounting positions (see figure 4)

Unit Size	Approximate Capacity - Litres							
	5:1				13:1, 20:1 & 25:1			
Mounting Position	1	2	3	4	1	2	3	4
015	0.3	0.3	0.3	0.4	0.25	0.4	0.3	0.4
103	0.5	0.5	0.5	0.6	0.4	0.6	0.5	0.6
107	0.8	0.9	0.8	1	0.7	0.9	0.8	0.9
115	1.2	1.7	1.4	1.8	1	1.8	1.4	1.6
203	2.5	2.6	2.4	2.5	2.3	2.6	2.4	2.2
207	3.3	3.2	3.2	3.3	3	3.2	3.2	3.2
215	4.1	5.3	4.1	5.8	3.8	5.5	4.2	5.1
307	5.7	8.6	5.9	8.6	5.4	8.5	5.9	8.3
315	10.9	18.4	13.6	18.4	9.1	16.4	12.6	15.4
407	15.2	21.7	25.2	20.7	12.7	21.7	15.7	19.2
415					12.5	13.5	24.0	11.5
507					22.5	34.5	52.0	27.0
608					36.0	50.0	79.0	45.0

Normal operating positions are shown in fig. 4. Note that the reducer is supplied with four plugs. After the reducer has been mounted in its running position, the plugs must be located as shown in fig. 4 for the appropriate mounting position. If the reducer is not within 20° of one of the positions shown, the oil level plug cannot be safely used to check the oil level. This can be overcome by disconnecting the torque-arm and swinging the reducer around to one of the positions shown.

Because of the many positions of the reducer it may be necessary, or desirable, to make special adaptations using the plug holes in the reducer with standard pipe fitting, standpipes or oil level gauges.

Recommended Mineral Oil Lubricant Viscosities

	Ambient Temp °C	5:1 Ratio Gearbox				13:1, 20:1 & 25:1 Ratio Gearbox				
		0-100 rev/min	101-200 rev/min	201-400 rev/min		0-20 rev/min	21-50 rev/min		51-120 rev/min	
		015-407	015-407	015-107	115-407	015-407	015-115	203-407	015-115	203-407
I.S.O. Viscosity Grade	-10 to +5	100	100	100	68	150	150	150	100	100
	6 to 25	460	320	320	220	680	680	460	460	320
	26 to 40	800	680	680	460	800	800	800	680	460

Sumitomo Cyclo Europe recommends:

Mobil Mobilgear 600 series mineral oil
Mobil SHC XMP 320 synthetic oil is suitable for all ambient temperatures and all input speeds

SUMITOMO CYCLO EUROPE

TO INSTALL BACKSTOP

If reducer is filled with oil, drain off oil before proceeding further.

1. Remove backstop cover ref. 12. Remove all traces of sealant from backstop cover and gear case faces.

2. Determine direction of required shaft rotation.

Sizes 015 & 103

The shaft is free to rotate in the direction of the arrow marked on the backstop cage.

With the backstop cage in the correct orientation, press the backstop into the outer race.

Fit the 'O' ring seal onto the outer race, ensuring the ring is seated fully in the groove. Push the assembly into the housing.

Secure using the screws provided and the lockwashers from the original backstop cover. Finally, after checking for correct shaft rotation, fit the sealing cap into the outer race.

Sizes 107 - 407

Fit the internal circlip into the groove in the outer race.

Slide the 'O' rings over each end of the outer race and ensure both rings are fully engaged in their respective grooves.

Note that on size 315 the two 'O' rings are different diameters.

With the backstop race fitted in the correct direction into the outer race, feed the assembly into the housing, rotating the shaft in its free direction will assist.

When the outer race is fully home, rotate the shaft in its backstopping direction.

If the assembly is correct, the outer race will now rotate with the shaft. Use this feature to align the screw holes.

Place the original backstop cover onto the projecting outer race spigot and secure the complete assembly using the screws provided.

3. Refill the reducer with correct grade of oil.

Note: Do not use E.P. oils other than those recommended when using a backstop.

IMPORTANT

When pushing the backstop assembly into the housing, it is important not to hammer the assembly at any time.

The assembly may be tapped gently if necessary.

To change the backstopping direction at any time, it is necessary to remove the sprag assembly and turn it end for end.

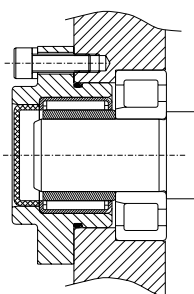

Sizes 015-103

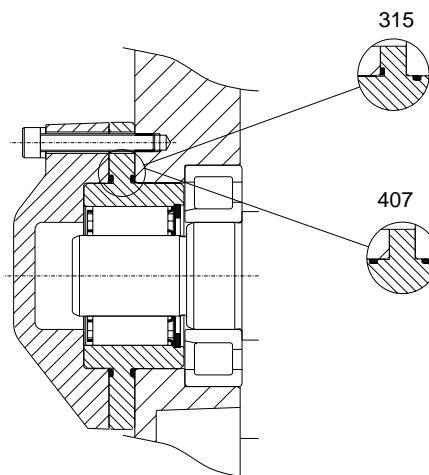

Sizes 107-407

TO INSTALL BACKSTOP

If reducer is fitted with oil, drain off oil before proceeding further.

1. Remove backstop cover and recover the gasket (where fitted) ref. 12 & 13 and input bearing distance piece (ref. 88). Refer to Parts Identification section.

2. Marked on the outer race of the backstop is an arrow. This indicates that the input shaft will rotate freely in this direction after the backstop has been installed.

If it is necessary to remove it, turn it end for end, and re-install it. Match the arrow on backstop to direction of rotation desired for the input shaft.

3. Place the two inner race keys (ref. 62) in the input shaft keyways. For ease of installation the backstop, complete with inner race should be pushed into the reducer as a unit.

When pushing backstop into reducer it is important not to hammer on the backstop, but it can be tapped gently if necessary.

Place circlip (ref. 63) into groove in input shaft.

4. Line up keyway in backstop outer race with keyway in backstop housing by rotating the input shaft in the opposite direction to its driving rotation. If the backstop is properly installed it will rotate with the input shaft.

5. Insert key (ref. 61) in the aligned keyways.

6. Replace gasket and backstop cover and refill reducer with oil.

7. Check input shaft for end-float 0.05mm max.

IMPORTANT

If for any reason it is necessary to remove a backstop from an operational unit it is essential that (ref. 88), the input bearing distance piece, is fitted into the vacant backstop housing, and the input shaft end-float checked before restarting the unit.

Note: Do not use E.P. oils other than those recommended when using a backstop.

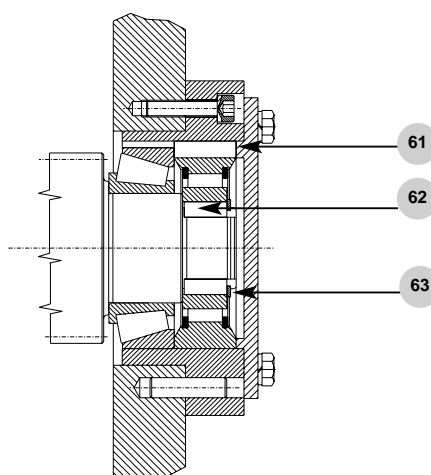

SUMITOMO CYCLO EUROPE

H S M Drive

**H S M Drive
Parts Codes**

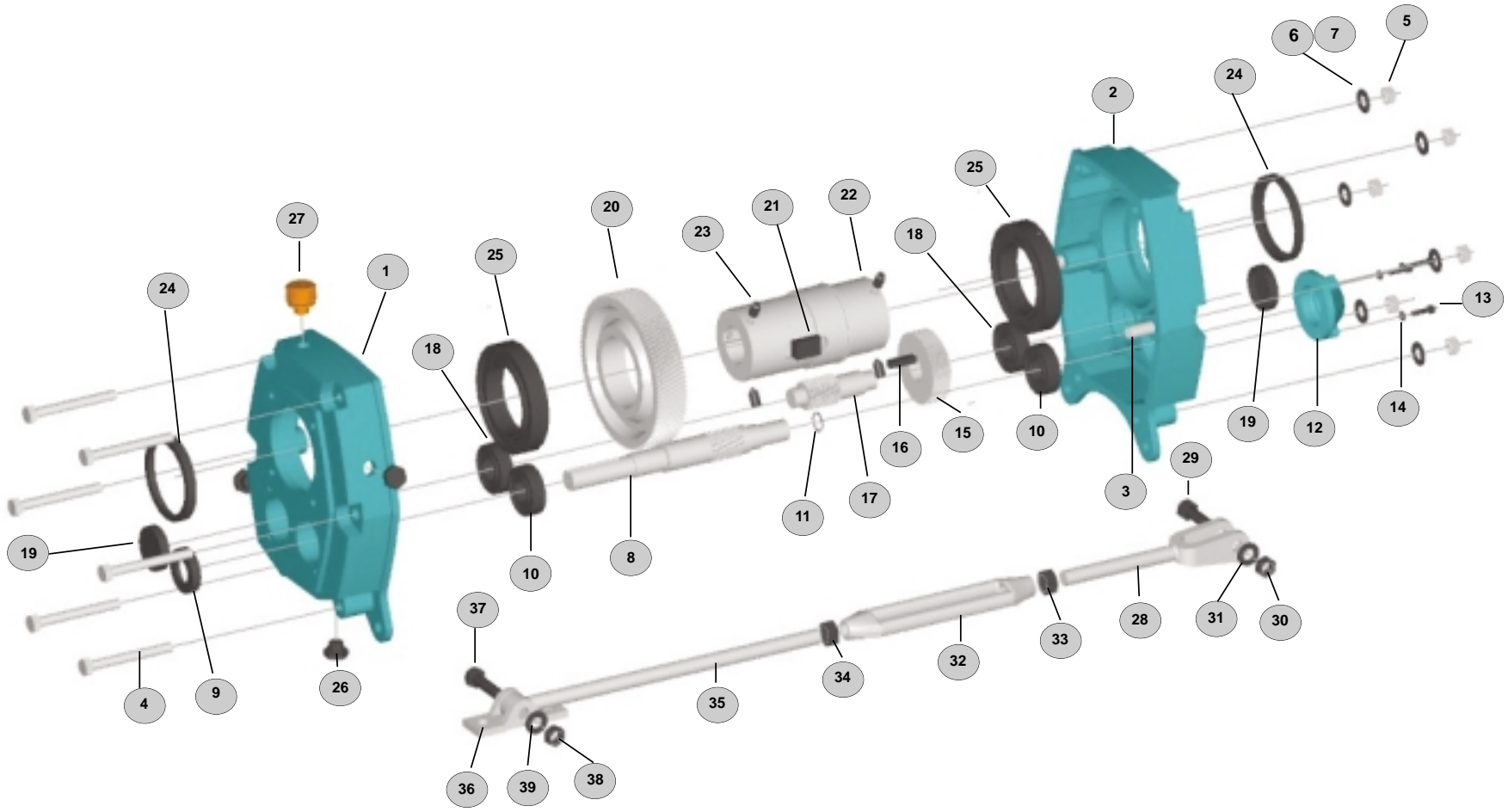

Part Ident	Description	No. Req	015	103	107	115	203	
1	Case IPS	1	116ACC6001	116BCD6001	116CCCC6001	116DCC6001	116ECC6001	
2	Case BSS	1	116ACD6001	116BCD6001	116CCD6001	116DCD6001	116ECD6001	
3	Hollow dowel	2	16A7004	016A7004	016C7004	016C7004	016E7004	
4	Case bolt	*	943706	943702	943830	943835	943840	
5	Case nut	*	943810	943810	943811	943811	943812	
6	Case plain washer	4	943820	943820	943821	943821	943872	
7	Case lockwasher	*	943870	943870	943871	943871	943872	
8	Input shaft metric & pinion (5:1) AGMA	1	116APA6005	116BPA6005	116CPA6005	116DPA6005	116EPA6005	
	Input shaft metric & pinion (13:1) AGMA	1	116APB6005	116BPB6005	116CPB6005	116DPB6005	116EPB6005	
	Input shaft metric & pinion (20:1) AGMA	1	116APA6013	116BPA6013	116CPA6013	116DPA6013	116EPA6013	
	Input shaft metric & pinion (25:1) AGMA	1	116APB6013	116BPB6013	116CPB6013	116DPB6013	116EPB6013	
	Input shaft metric & pinion (20:1) AGMA	1	116APA6020	116BPA6020	116CPA6020	116DPA6020	116EPA6020	
	Input shaft metric & pinion (25:1) AGMA	1	116APB6020	116BPB6020	116CPB6020	116DPB6020	116EPB6020	
	Input shaft metric & pinion (25:1) AGMA	1	116APA6025	116BPA6025	116CPA6025	116DPA6025	116EPA6025	
9	Input shaft oilseal	1	946040	946030	946031	946032	946033	
10	Input shaft bearing	2	941000	941801	941802	941803	941804	
11	Input shaft retaining ring (20:1) (25:1)	1	944180	944180	944181	944196	-	
			-	944180	-	-	944196	
12	Backstop cover	1	116AED6000	116BED6000	116CED6000	116DED6000	116EED6000	
13	Backstop cover screw	3	942570	942571	942572	942572	942601	
14	Backstop cover lockwasher	3	943687	943687	943687	943687	943680	
15	1st. Reduction gear (13:1)	1	116AGA6013	116BGA6013	116CGA6013	116DGA6013	116EGA6013	
	1st. Reduction gear (20:1)	1	116AGA6020	116BGA6020	116CGA6020	116DGA6020	116EGA6020	
	1st. Reduction gear (25:1)	1	116AGA6025	116BGA6025	116CGA6025	116DGA6025	116EGA6025	
16	1st. Reduction gear key	1	944327	944320	944321	944321	944322	
17	Intermediate pinion	1	116APC6005	116BPC6005	116CPC6005	116DPC6005	116EPC6005	
18	Intermediate bearing	2	941000	941801	941802	941803	941804	
19	Intermediate cover	2	016A7025	016B7025	016C7025	016D7025	016E7025	
20	2nd. Reduction gear	1	116AGB6005	116BGB6005	116CGB6005	116DGB6005	116EGB6005	
21	2nd Reduction gear key	1	944319	944310	944311	944312	944313	
22	Output hub	1	See output bore table page 22 & 23 for hub codes					
23	Output hub screw	4	942612	942612	942706	942706	942714	
24	Output hub oilseal	2	946041	946023	946024	946025	946026	
25	Output hub Deep groove bearing Taper roller	2	941350	941351	941352	941353	941354	
			-	941220	941221	941211	941212	
26	Pipe plug	3	942395	942395	942395	942395	942392	
27	Breather plug	1	946097	946097	946097	946097	946098	
Torque arm components:								
28	rod end	1	040M7102	040M7102	040N7102	040N7102	040A7102	
29	rod end bolt	1	943701	943701	943756	943756	943715	
30	rod end nut	1	943810	943810	943811	943811	943813	
31	rod end lockwasher	1	943681	943681	943682	943682	943684	
32	turnbuckle	1	016B7045	016B7045	016D7045	016D7045	016F7045	
33	locknut RH	1	943812	943812	943813	943813	943815	
34	locknut LH	1	943790	943790	943791	943791	943792	
35	extension	1	016B7043	016B7043	016D7043	016D7043	016F7043	
36	fulcrum	1	016B6046	016B6046	040N6101	040N6101	016F7046	
37	fulcrum bolt	1	943832	943832	943843	943843	943715	
38	fulcrum nut	1	943811	943811	943812	943812	943813	
39	fulcrum lockwasher	1	943682	943682	943683	943683	943684	

Key: * 6 required sizes 015 to 215, 10 required sizes 307 to 315, 12 required size 407

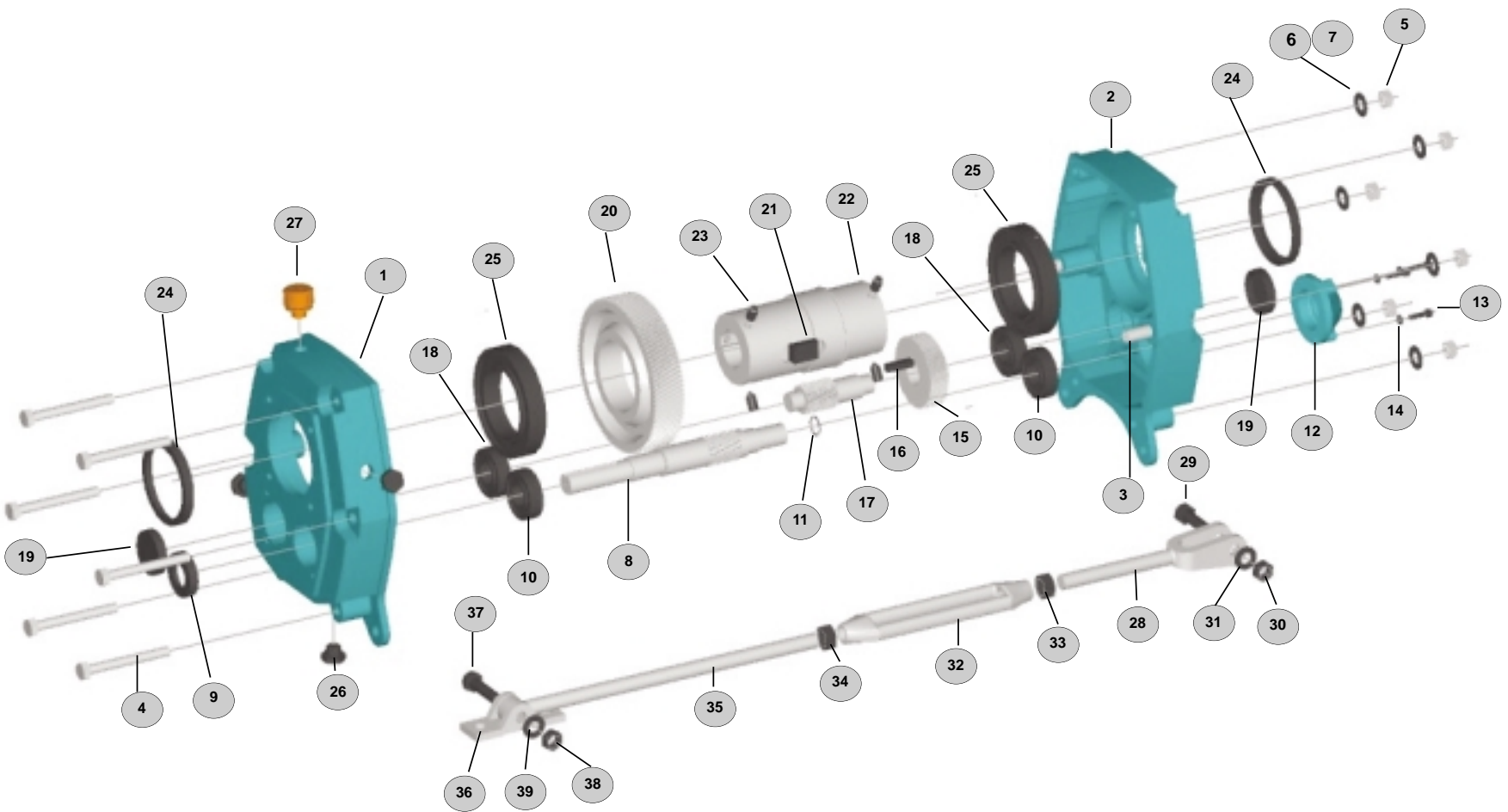

Part Ident	Description	No. Req	207	215	307	315	407	
1	Case IPS	1	116FCC6001	116GCC6001	116HCC6001	116JCC6001	116SCC6001	
2	Case BSS	1	116FCD6001	116GCD6001	116HCD6001	116JCD6001	116SCD6001	
3	Hollow dowel	2	016F7004	016F7004	016H7004	016H7004	016K7004	
4	Case bolt	*	943850	943851	943841	943842	016S7005	
5	Case nut	*	943813	943813	943812	943812	943813	
6	Case plain washer	4	943823	943823	943822	943822	943823	
7	Case lockwasher	*	943873	943873	943872	943872	943873	
8	Input shaftmetric & pinion (5:1)AGMA	1	116FPA6005	116GPA6005	116HPA6005	116JPA6005	116SPA6005	
	Input shaftmetric & pinion (13:1)AGMA	1	116FPB6005	116GPB6005	116HPB6005	116JPB6005	116SPB6005	
	Input shaftmetric & pinion (20:1)AGMA	1	116FPA6013	116GPA6013	116HPA6013	116JPA6013	116SPA6013	
	Input shaftmetric & pinion (25:1)AGMA	1	116FPB6013	116GPB6013	116HPB6013	116JPB6013	116SPB6013	
	Input shaftmetric & pinion (20:1)AGMA	1	116FPA6020	116GPA6020	116HPA6020	116JPA6020	116SPA6020	
	Input shaftmetric & pinion (25:1)AGMA	1	116FPB6020	116GPB6020	116HPB6020	116JPB6020	116SPB6020	
9	Input shaftmetric & pinion (25:1)AGMA	1	116FPA6025	116GPA6025	116HPA6025	116JPA6025	116SPA6025	
	Input shaft oilseal	1	116FPB6025	116GPB6025	116HPB6025	116JPB6025	116SPB6025	
10	Input shaft bearing	2	946034	946035	946036	946037	946038	
11	Input shaft retaining ring (20:1) (25:1)	1	941805	941806	941807	941808	941809	
12	Backstop cover	1	-	944184	944185	944186	-	
			944182	116GFF6001	116HFF6001	116JFF6001	944088	
13	Backstop cover screw	3	116FED6000	116GED6000	116HED6000	116JED600	116SED6000	
14	Backstop cover lockwasher	3	942751	942784	942784	942811	942811	
15	1st. Reduction gear (13:1)	1	943681	943682	943682	943683	943683	
	1st. Reduction gear (20:1)	1	116FGA6013	116GGA6013	116HGA6013	116JGA6013	116SGA6013	
	1st. Reduction gear (25:1)	1	116FGA6020	116GGA6020	116HGA6020	116JGA6020	116SGA6020	
16	1st. Reduction gear key	1	116FGA6025	116GGA6025	116HGA6025	116JGA6025	116SGA6025	
17	Intermediate pinion	1	944323	944324	944325	944326	944326	
18	Intermediate bearing	2	116FPC6005	116GPC6005	116HPC6005	116JPC6005	116SPC6005	
19	Intermediate cover	2	941805	941806	941807	941808	941809	
20	2nd. Reduction gear	1	016F7025	946285	946285	016J7025	016S7025	
21	2nd. Reduction gear key	1	116FGB6005	116GGB6005	116HGB6005	116JGB6005	116SGB6005	
22	Output hub	1	944314	944315	944316	944317	944318	
23	Output hub screw	4	See output bore table page 22 & 23 for hub codes					
24	Output hub oilseal	2	942714	942727	942727	942727	942730	
25	Output hub bearing	2	946016	946027	946028	946029	946315	
	Deep groove Taper roller	2	941355	941356	941357	941358	941050	
26	Pipe plug	3	941213	941214	941215	941216	941222	
27	Breather plug	1	942392	942392	942392	942392	942392	
28	Torque arm components: rod end	1	946098	946098	946098	946098	946098	
29	rod end bolt	1	040A7102	040B7102	040B7102	040B7102	040B7102	
30	rod end nut	1	943715	943726	943726	943726	943726	
31	rod end lockwasher	1	943813	943815	943815	943815	943815	
32	turnbuckle	1	943684	943685	943685	943685	943685	
33	locknut RH	1	016F7045	016H7045	016H7045	016H7045	016H7045	
34	locknut LH	1	943815	943816	943816	943816	943816	
35	extension	1	943792	943793	943793	943793	943793	
36	fulcrum	1	016F7043	016H7043	016H7043	016H7043	016H7043	
37	fulcrum bolt	1	016F7046	016H6046	016H6046	016H6046	016H6046	
38	fulcrum nut	1	943715	943855	943855	943855	943855	
39	fulcrum lockwasher	1	943813	943813	943813	943813	943813	
			943684	943684	943684	943684	943684	

Key: * 6 required sizes 015 to 215, 10 required sizes 307 to 315, 12 required size 407

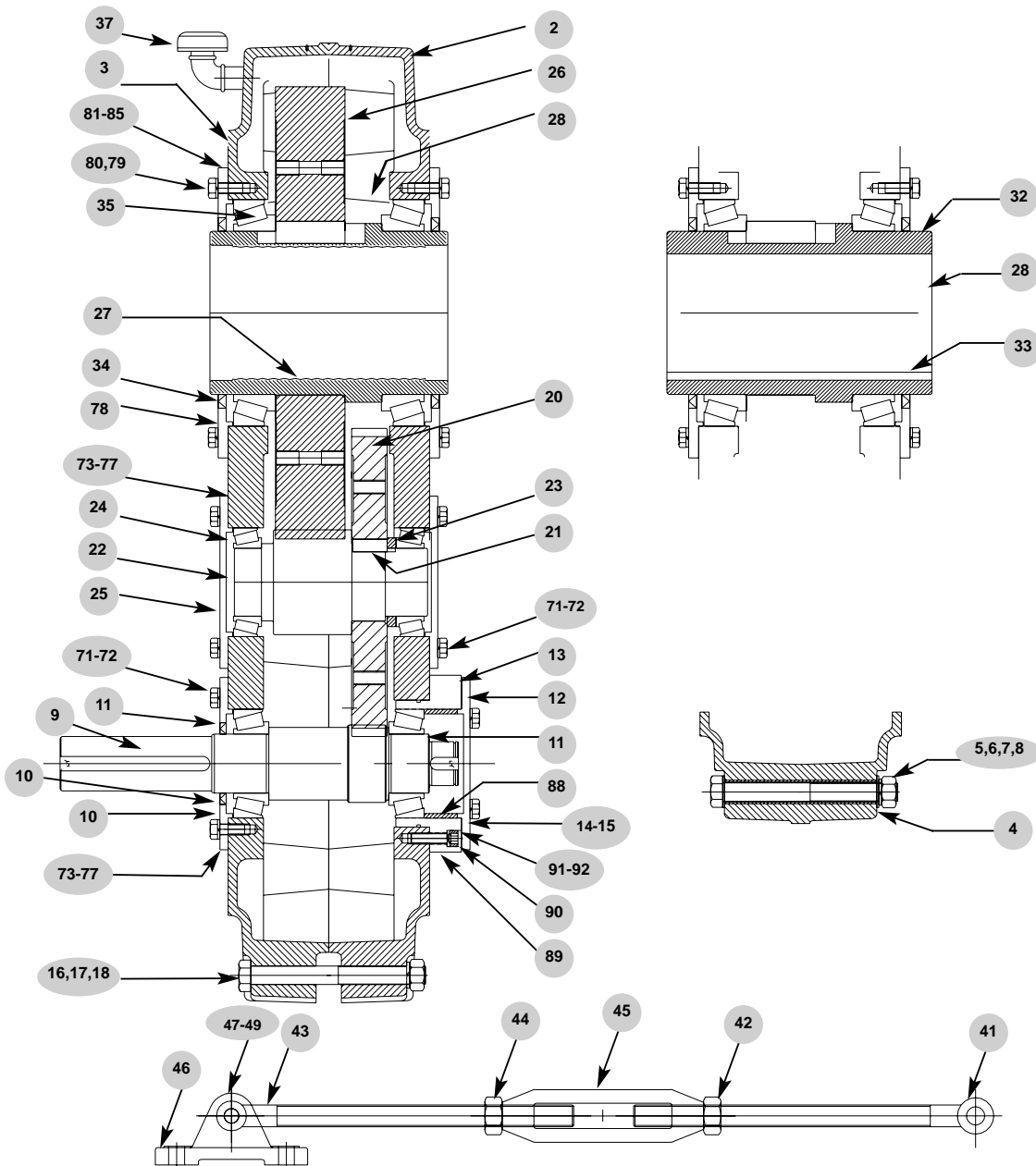

Part Ident	Description	No. Req	415	507	608
2	Case Right Hand	1	16K6002	16L6002	16M6002
3	Case Left Hand	1	16K6003	16L6003	16M6003
4	Hollow Dowel	2	16K7004	16L7004	16M7004
5	Case Bolt	See (1)	16K7005	16L7005	16M7005
6	Case Nut	See (1)	943813	943815	943815
7	Case Plain Washer	4	943823	943825	943825
8	Case Lockwasher	See (1)	943823	943825	943825
9	Input Shaft & Pinion (13:1)	1	16K6100	16L6100	16M6100
10	Input Shaft Oil Seal	1	946307	946308	946314
11	Input Shaft Bearing	2	941257	941370	941373
12	Backstop Cover	1	16K6012	16L6012	16M6012
13	Backstop Cover Gasket	1	16K7075	16L7075	16M7075
14	Backstop Cover Screw	6	943751	943762	943773
15	Backstop Cover Lockwasher	6	943682	943683	943684
16	Torque Arm Case Bolt	2	16K7016	16L7016	16M7016
17	Torque Arm Case Bolt Nut	2	943815	943816	943818
18	Torque Arm Case Bolt Lockwasher	2	943685	943689	943880
19	1st Reduction Gear (13:1)	1	16K6101	16L6101	16M6101
20	1st Reduction Gear (20:1)	1	16K6111	16L6111	16M6111
21	1st Reduction Gear Key	3	16K7021	16L7021	16M7021
22	Intermediate Pinion (13:1, 20:1)	1	16K6022	16L6022	16M6022
23	Intermediate Pinion Distance Piece	1	16K6023	16L6023	16M6023
24	Intermediate Bearing	2	941258	941371	941373
25	Intermediate Cover	2	16K6012	16L6012	16M6012
26	2nd Reduction Gear	1	16K6026	16L6026	16M6026
27	2nd Reduction Gear Key	1	16K6127	16L6127	16M6127
28	Output Hub - STD Bore	1	16K6105	16L6105	16M6105
29	Output Hub - Taper-grip	1	16K6107	16L6107	16M6107
32	Output Hub - collar screw (over key)**	1	942731	942730	942730
33	Output Hub - collar screw (over shaft)**	3	942732	942734	942734
34	Output Hub Oilseal	2	946315	946316	916317
35	Output Hub Bearing	2	941259	941372	941374
36	3/4 BSP Plug	7	942394	942394	942394
37	3/4 Breather Plug	1	946093	946093	946093
38	Breather Adapter Bend	1	946180	946180	946180
41	Torque Arm Rod End	1	16K7041	16L7041	16M7041
42	Rod End Locknut	1	943816	943817	943817
43	Torque Arm Extension	1	16H7043	16L7043	16L7043

Notes: 1. 10 required size 415, 12 required size 507, 15 required size 608

** Not supplied on Taper-Grip® Hubs

Part Ident	Description	No. Req	415	507	608
44	Extension Locknut	1	943793	943794	943794
45	Turnbuckle	1	16H7045	16L7045	16L7045
46	Fulcrum	1	16H6046	16L6046	16L6046
47	Fulcrum Bolt	1	943855	16L6047	16L6047
48	Fulcrum Bolt Nut	1	943813	943818	943818
49	Fulcrum Lockwasher	1	943684	943880	943880
70	Input Shaft Cover	1	16K6070	16L6070	16M6070
71	Input & Intermediate Cover Screw	18	943751	943762	943773
72	Input & Intermediate Cover Screw Lockwasher	18	943682	943683	943684
73	Input & Inter. Cover Shim (0.50mm)	AR	16K7073	16L7073	16M7073
74	Input & Inter. Cover Shim (0.25mm)	AR	16K7074	16L7074	16M7074
75	Input & Inter. Cover Shim (0.15mm)	AR	16K7075	16L7075	16M7075
76	Input & Inter. Cover Shim (0.07mm)	AR	16K7076	16L7076	16M7076
77	Input & Inter. Cover Shim (0.05mm)	AR	16K7077	16L7077	16M7077
78	Output Cover	2	16K6078	16L6078	16M6078
79	Output Cover Screw	(see 2)	943762	943773	943723
80	Output Cover Lockwasher	(see 2)	943683	943684	943685
81	Output Cover Shim (0.5mm)	AR	16K7081	16L7081	16M7081
82	Output Cover Shim (0.25mm)	AR	16K7082	16L7082	16M7082
83	Output Cover Shim (0.15mm)	AR	16K7083	16L7083	16M7083
84	Output Cover Shim (0.07mm)	AR	16K7084	16L7084	16M7084
85	Output Cover Shim (0.05mm)	AR	16K7085	16L7085	16M7085
87	Backstop Housing Dowel	3	16K6087	16L6087	16M6087
88	Input Bearing Distance Piece	1	16K6088	16L6088	16M6088
89	Backstop & Bearing Housing	1	16K6089	16L6089	16M6089
90	'O' Ring	1	946422	946421	946420
91	Housing Locking Screw	6	942781	942810	942801
92	Housing Locking Screw Lockwasher	6	943682	943683	943684

Notes: 2. 12 required size 415 & 507, 16 required size 608

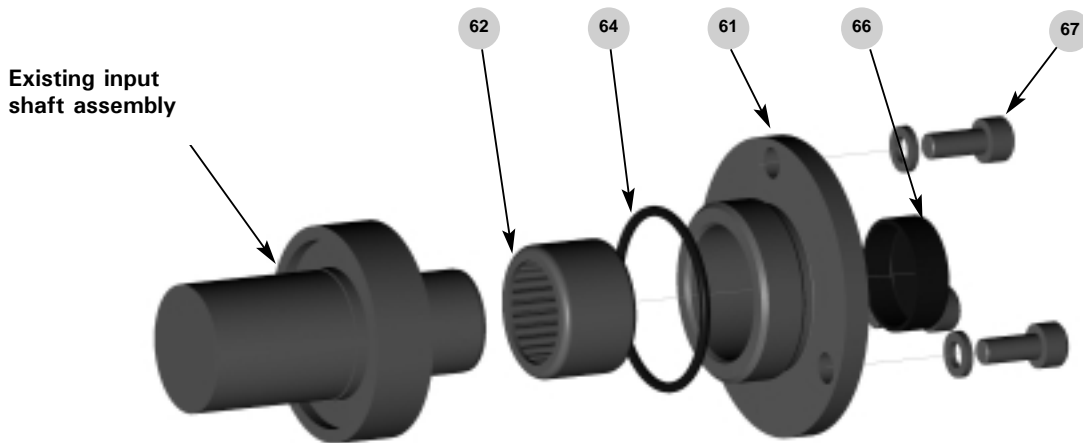

Sizes 015 & 103

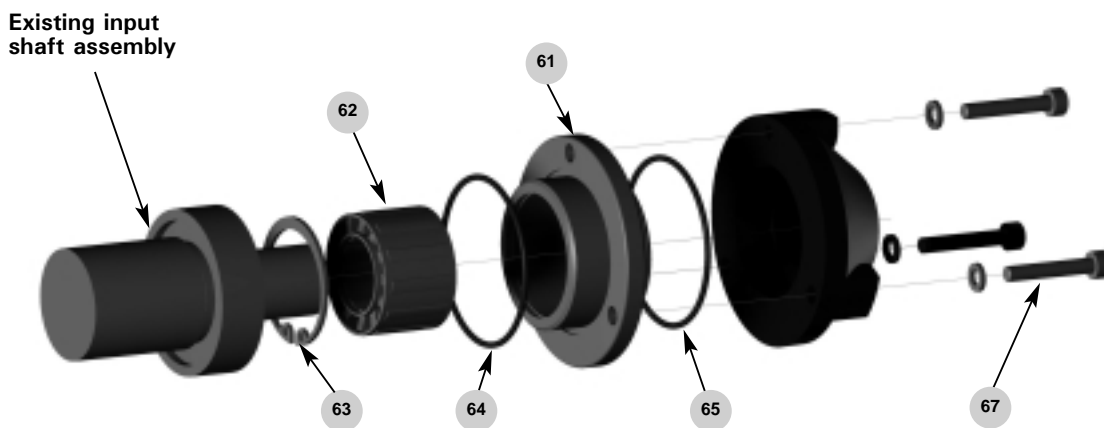

Sizes 107 to 407

Unit size	Assembly	Description (ref.)						
		Outer Race (61)	Sprag Clutch (62)	Circlip (63)	Inner O-ring (64)	Outer O-ring (65)	Cover (66)	Screw (67)
015	044A0100	044A6101	0947262	-	0946450	-	0946288	0942574
103	044B0100	044B6101	0947263	-	0946451	-	0946289	0942570
107	044C0100	044C6101	0947040	0944120	0946452	0946452	-	0942573
115	044D0100	044D6101	0947040	0944120	0946453	0946453	-	0942573
203	044E0100	044E6101	0947041	0944121	0946454	0946454	-	0942602
207	044F0100	044F6101	0947042	0944122	0946455	0946455	-	0942752
215	044G0100	044G6101	0947043	0944123	0946456	0946456	-	0942781
307	044H0100	044H6101	0947044	0944124	0946456	0946456	-	0942781
315	044J0100	044J6101	0947045	0944125	0946457	0946458	-	0942814
407	044S0100	044S6101	0947045	0944125	0946459	0946459	-	0942810

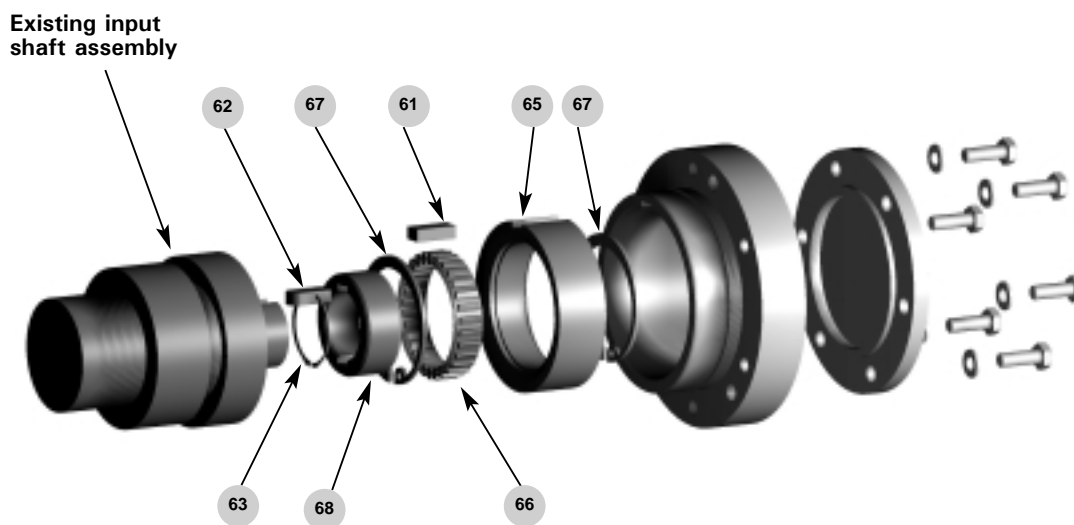

Sizes 415 to 608

Unit size	Assembly	Description (ref.)						
		Outer Race (61)	Inner race key (62)	Inner race circlip (63)	Backstop outer race (65)	Sprag clutch (66)	Backstop Outer race circlip (67)	Inner race (68)
415	044K0002	016K7061	016K7062	944262	044K6001	947312	944155	044K6002
507	044L0002	016L7061	016L7062	944188	044L6001	947313	944156	044L6002
608	044M0002	016M7062	016M7062	944263	044M6001	947311	944290	044M6002