

SM 2862-5125.B

Dimensions (Unit:mm)

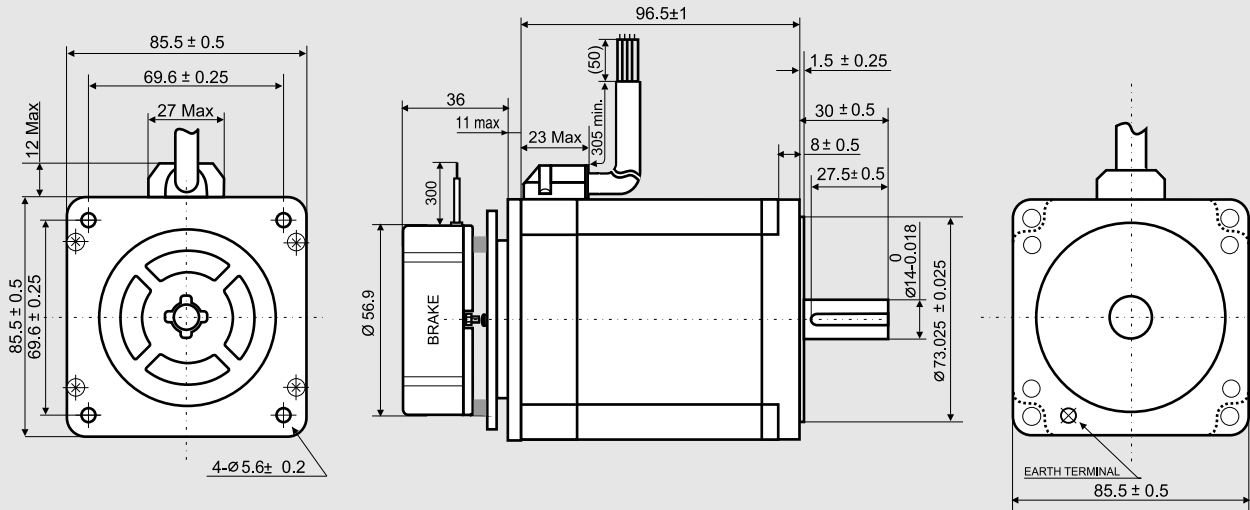

SANYO DENKI MOTOR FEATURES

MODEL	SM 2862-5125.B	
SANYO DENKI MOTOR CODE	SM 2862-5125	
BASIC STEP ANGLE	$1.8^\circ \pm 0.09^\circ$	
BIPOLAR PARALLEL CURRENT	(Amp)	4.0
RESISTANCE	(Ohm)	0.83
INDUCTANCE	(mH)	6.4
BIPOLAR HOLDING TORQUE	(Ncm)	700
ROTOR INERTIA	($\text{Kg} \cdot \text{m}^2 \times 10^{-7}$)	3000
THEORETICAL ACCELERATION	($\text{rad} \times \text{sec.}^{-2}$)	23300
BACK E.M.F.	(V/Krpm)	175
MASS	(Kg)	3.4
INTERNATIONAL STANDARDS	UL, CSA	
INSULATION VOLTAGE	(V)	250 VAC (350 VDC)
PROTECTION DEGREE - INSULATION CLASS	IP43 - F	
LEADS CODE	V	

R.T.A. - s.r.l. PAVIA (ITALY) SANYO DENKI CO.,Ltd (JAPAN)

BRAKE FEATURES

STATIC TORQUE	(Nm)	3.3
DUTY CYCLE		50% max.
VOLTAGE	(Volt)	24 VDC
POWER	(W)	11
RELEASE TIME	(ms)	300



Ed. 2 Allegato EIMC - 10 - 14



CAUTION

Use for safety related functions is forbidden (EN 60204-1). Moreover, when the application arrangement is in such way that a motor fault or failure could generate a risk for property or human life, external independent safety protection system must be provided in the machine.

